

: ± ")
 !GF: GB: @9B8'K #F9H9BHC B @H7 <
 fG G8L!%\$!&!LL!LL"LL!GF'G<C'K BL
 fC B@M5J 5 @6@CB'1\$) H-FI '!' \$'DC G<
 fG5A 9'5G: ÷ "%Z! B@GG'C H-9FK @9'G'5H98L

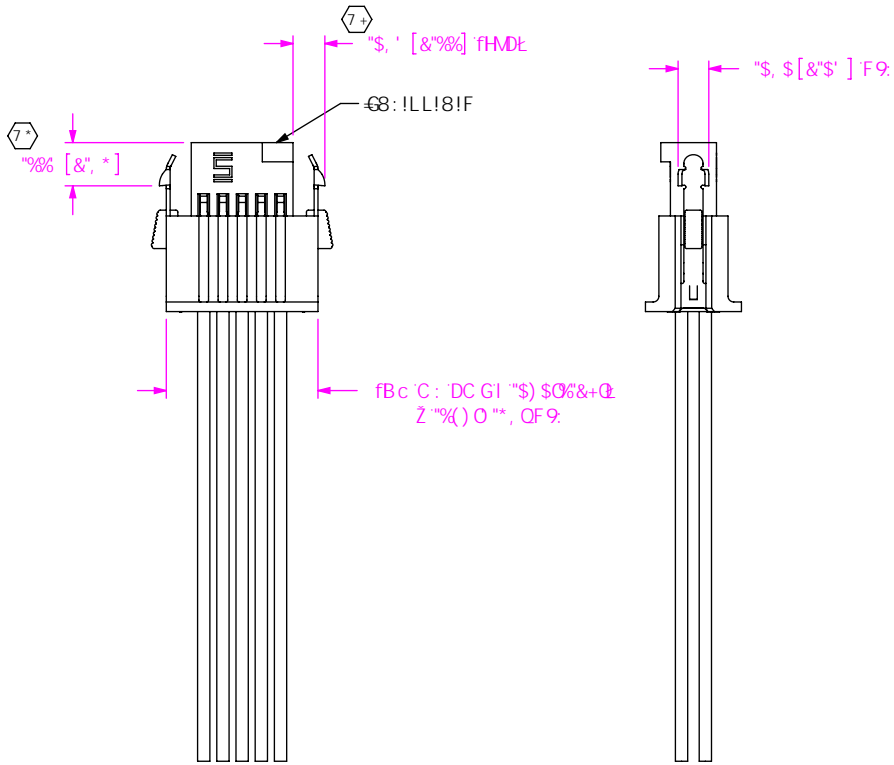

: ± "*" ⁷ ₇
 !8F: 8C! 6@9B8'K #F9H9BHC B @H7 <
 fG G8L!%\$!&!LL!LL"LL!8F'G<C'K BL
 fC B@M5J 5 @6@CB'1\$) H-FI '!' \$'DC G<
 fG5A 9'5G: ÷ "%Z! B@GG'C H-9FK @9'G'5H98L

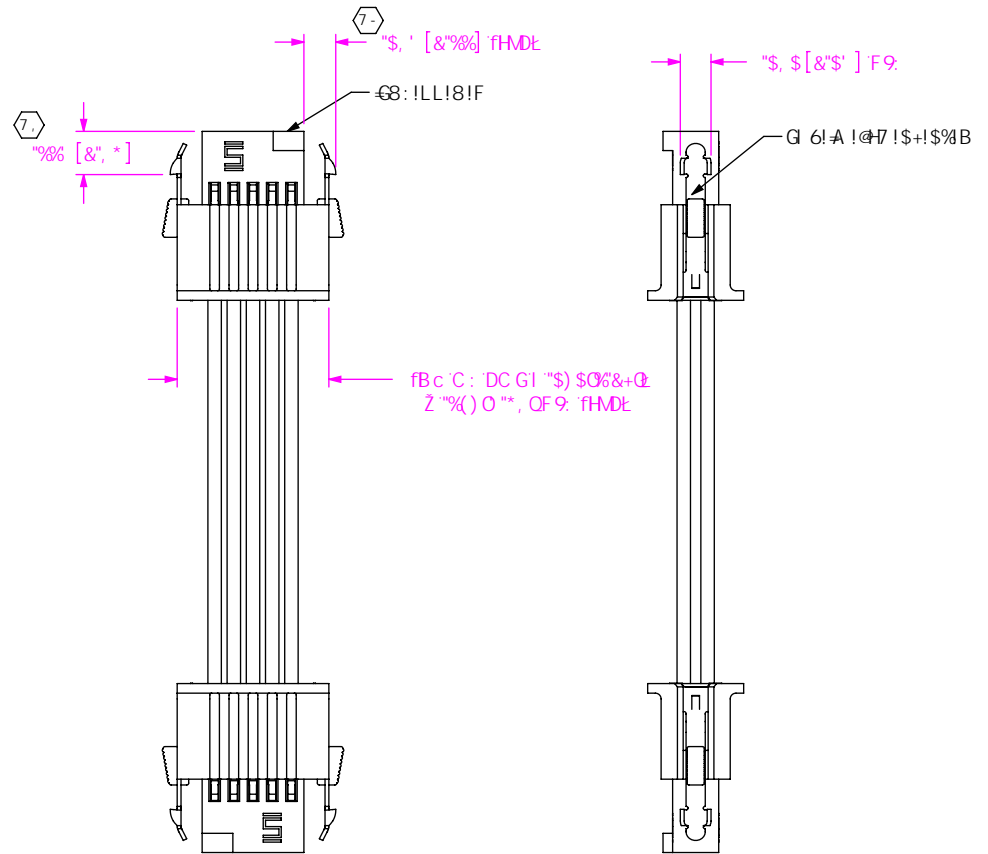

SFSD color coded wire sequence

pin #	COLOR									
	brown	red	orange	yellow	dk green	violet	gray	white	black	dk blue
1	2	3	4	5	6	7	8	9	10	
11	12	13	14	15	16	17	18	19	20	
21	22	23	24	25	26	27	28	29	30	
31	32	33	34	35	36	37	38	39	40	
41	42	43	44	45	46	47	48	49	50	
51	52	53	54	55	56	57	58	59	60	
61	62	63	64	65	66	67	68	69	70	
71	72	73	74	75	76	77	78	79	80	
81	82	83	84	85	86	87	88	89	90	
91	92	93	94	95	96	97	98	99	100	

:PBK : PA 67PA 7H PG G8LILLILLILLILLILLILLILLIA ?HG@8FK

DFC DF 4B5 FMB C H9
 H: G8C 71A 98H7 CB16 BG B: CFA 5HC B
 7C B: @9B8'K #F9H9BHC B @H7 <
 GSA H97 2 87 588 G-5 @6@CB'1\$) H-FI '!' \$'DC G<
 CF H'5BG 9F98 HC CH: 9F 8C 71A 98H6C F
 8 47 @G 98 HC CH: 9F GC F1 098 : CF 58M
 DI FDC @9 CH: 9F H: 5B H: 5HK < 7 < #K 5G
 C 616 B 98 K #K C1 H: 9 9L DF 9098 K F #H8
 7 C B 98 HC: GSA H97 2 87 "

8C : BCHG7 5 @ 8F5K : B:

G: 99HG7 5 @ 9 (%)



) & \$ D5F? 95GH6@ 8ZB9K 5 @5BM'B (+%) \$
 D<C B9 ; %&L - ((1*+' ' : SL ; %&L - ()) \$ (+
 YIA UJ ; b z 4 G5A H97 'Wc'a 'WcXY.') &&

89G7 F @HC B:
 "\$) \$O%&+QC 7 ? 9H8 @7 F 9H9 7 5 6 @9 5 GG9A 6 @M

8K : "'BC"

G: G8L!LL!LLL!LLL!LL!LL"LL!LL!LLL

6M 6F5H7 <9F) #) &\$\$) G< 99H''C: '