

# Coaxial Directional Coupler

50Ω

1 to 500 MHz

ZFDC-10-1+  
ZFDC-10-1



BNC version shown  
CASE STYLE: K18

## Maximum Ratings

Operating Temperature	-55°C to 100°C
Storage Temperature	-55°C to 100°C

## Coaxial Connections

INPUT	1
OUTPUT	2
COUPLED	3

## Features

- excellent directivity, 33 dB typ.
- excellent mainline loss, 0.8 dB typ.
- rugged shielded case

## Applications

- VHF/UHF
- instrumentation
- communication receivers & transmitters
- amateur radio

Connectors	Model	Price	Qty.
BNC	ZFDC-10-1(+)	\$44.95	(1-9)
SMA	ZFDC-10-1-S(+)	\$49.95	(1-9)
N-TYPE	ZFDC-10-1-N(+)	\$49.95	(1-9)
BRACKET (OPTION "B")		\$2.50	(1+)

+ RoHS compliant in accordance with EU Directive (2002/95/EC)

The +Suffix identifies RoHS Compliance. See our web site for RoHS Compliance methodologies and qualifications.

## Directional Coupler Electrical Specifications

FREQ. RANGE (MHz)	COUPLING (dB)		MAINLINE LOSS <sup>1</sup> (dB)						DIRECTIVITY (dB)						VSWR (:1)	POWER INPUT (W)		
	Nom.	Flatness	L		M		U		L		M		U			Typ.	L	MU
			Typ.	Max.	Typ.	Max.	Typ.	Max.	Typ.	Min.	Typ.	Min.	Typ.	Min.				
1-500	10.5±0.25	±0.6	1.0	1.3	0.8	1.1	1.0	1.3	32	25	33	25	22	15	1.2	1.5	3.0	

L = low range [ $f_L$  to  $10 f_L$ ] M = mid range [ $10 f_L$  to  $f_U/2$ ] U = upper range [ $f_U/2$  to  $f_U$ ]  
1. Mainline loss includes theoretical power loss at coupled port.

## Outline Drawing

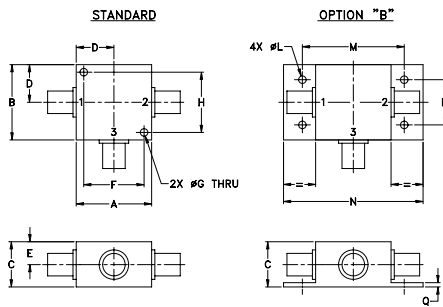

## Outline Dimensions (inch/mm)

A	B	C	D	E	F	G	H
1.25	1.25	.75	.63	.38	1.00	.125	1.000
31.75	31.75	19.05	16.00	9.65	25.40	3.18	25.40

J	K	L	M	N	P	Q	wt
--	--	.125	1.688	2.18	.75	.07	grams
--	--	3.18	42.88	55.37	19.05	1.78	70.0

## Typical Performance Data

Frequency (MHz)	Mainline Loss (dB) In-Out	Coupling (dB) In-Cpl	Directivity (dB)		Return Loss (dB)		Cpl
			In	Out	In	Out	
1.00	0.97	10.47	58.25	25.76	18.55	19.10	
5.00	0.78	10.32	57.52	32.88	20.94	21.28	
9.00	0.76	10.31	57.51	33.62	21.25	21.54	
67.00	0.77	10.34	46.55	30.69	21.30	21.61	
143.00	0.76	10.40	38.96	26.28	20.66	21.32	
220.00	0.76	10.49	33.22	23.55	19.85	20.86	
270.00	0.80	10.62	30.12	22.35	19.32	20.45	
330.00	0.83	10.74	27.02	21.34	18.68	19.89	
405.00	0.86	10.90	23.63	20.56	18.03	19.15	
500.00	0.85	11.04	20.05	20.16	17.44	18.20	

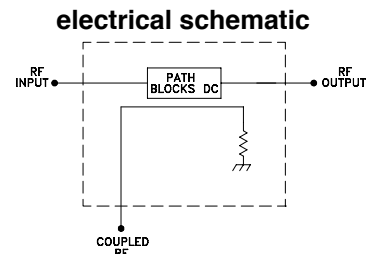
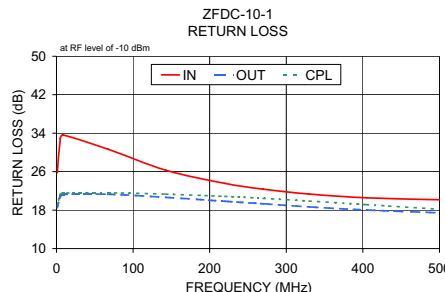
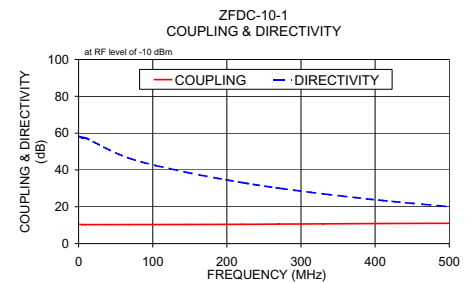
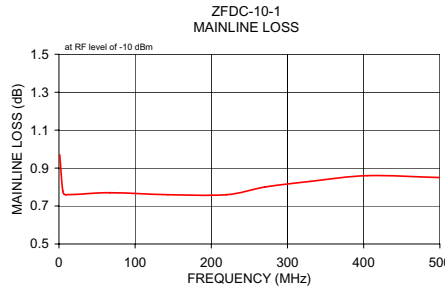

**Mini-Circuits**  
ISO 9001 ISO 14001 CERTIFIED

ALL NEW  
minicircuits.com

P.O. Box 350166, Brooklyn, New York 11235-0003 (718) 934-4500 Fax (718) 332-4661 For detailed performance specs & shopping online see Mini-Circuits web site



The Design Engineers Search Engine Provides ACTUAL Data Instantly From MINI-CIRCUITS At: [www.minicircuits.com](http://www.minicircuits.com)

REV. A  
M98898  
ZFDC-10-1  
WZ/TD/CP  
070523

RF/IF MICROWAVE COMPONENTS