



GENERAL DESCRIPTION



The ICS8523I-03 is a low skew, high performance 1-to-4 Differential-to-LVHSTL fanout buffer and a member of the HiPerClockS™ family of High Performance Clock Solutions from ICS. The ICS8523I-03 has two selectable clock inputs.

The input pairs can accept most standard differential input levels. The clock enable is internally synchronized to eliminate runt pulses on the outputs during asynchronous assertion/deassertion of the clock enable pin.

Guaranteed output and part-to-part skew characteristics make the ICS8523I-03 ideal for those applications demanding well defined performance and repeatability.

FEATURES

- 4 differential LVHSTL compatible outputs
- Selectable differential CLK0, nCLK0 and CLK1, nCLK1 clock inputs
- Clock input pairs can accept the following differential input levels: LVDS, LVPECL, LVHSTL, SSTL, HCSL
- Maximum output frequency: 650MHz
- Translates any single-ended input signal to LVHSTL levels with resistor bias on nCLK input
- Output skew: 50ps (maximum)
- Part-to-part skew: 400ps (maximum)
- Propagation delay: 1.2ns (typical)
- $V_{OH} = 1V$ (maximum)
- 3.3V core, 1.8V output operating supply
- Lead-Free package available
- -40°C to 85°C ambient operating temperature

BLOCK DIAGRAM

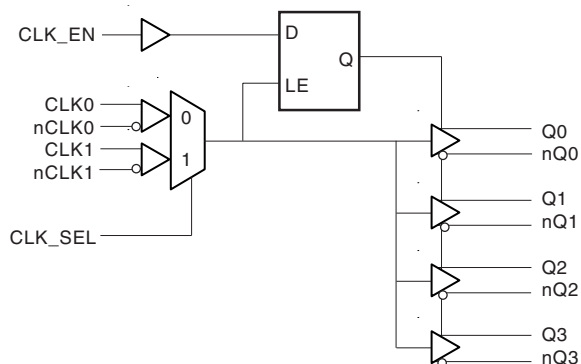

PIN ASSIGNMENT

GND	1	20	Q0
CLK_EN	2	19	nQ0
CLK_SEL	3	18	V _{DDO}
CLK0	4	17	Q1
nCLK0	5	16	nQ1
CLK1	6	15	Q2
nCLK1	7	14	nQ2
nc	8	13	V _{DDO}
nc	9	12	Q3
V _{DD}	10	11	nQ3

ICS8523I-03 20-Lead TSSOP

6.5mm x 4.4mm x 0.92mm body package

G Package
Top View

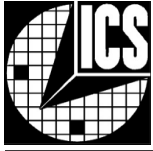

TABLE 1. PIN DESCRIPTIONS

Number	Name	Type		Description
1	GND	Power		Power supply ground.
2	CLK_EN	Input	Pullup	Synchronizing clock enable. When HIGH, clock outputs follow clock input. When LOW, Q outputs are forced low, nQ outputs are forced high. LVCMOS / LVTTTL interface levels.
3	CLK_SEL	Input	Pulldown	Clock select input. When HIGH, selects differential CLK1, nCLK1 inputs. When LOW, selects CLK0, nCLK0 inputs. LVCMOS / LVTTTL interface levels.
4	CLK0	Input	Pulldown	Non-inverting differential clock input.
5	nCLK0	Input	Pullup	Inverting differential clock input.
6	CLK1	Input	Pulldown	Non-inverting differential clock input.
7	nCLK1	Input	Pullup	Inverting differential clock input.
8, 9	nc	Unused		No connect.
10	V _{DD}	Power		Core supply pin.
11, 12	nQ3, Q3	Output		Differential output pair. LVHSTL interface levels.
13, 18	V _{DDO}	Power		Output supply pins.
14, 15	nQ2, Q2	Output		Differential output pair. LVHSTL interface levels.
16, 17	nQ1, Q1	Output		Differential output pair. LVHSTL interface levels.
19, 20	nQ0, Q0	Output		Differential output pair. LVHSTL interface levels.

NOTE: *Pullup* and *Pulldown* refer to internal input resistors. See Table 2, Pin Characteristics, for typical values.

TABLE 2. PIN CHARACTERISTICS

Symbol	Parameter	Test Conditions	Minimum	Typical	Maximum	Units
C _{IN}	Input Capacitance				4	pF
R _{PULLUP}	Input Pullup Resistor			51		KΩ
R _{PULLDOWN}	Input Pulldown Resistor			51		KΩ



TABLE 3A. CONTROL INPUT FUNCTION TABLE

Inputs			Outputs	
CLK_EN	CLK_SEL	Selected Source	Q0:Q3	nQ0:nQ3
0	0	CLK0, nCLK0	Disabled; LOW	Disabled; HIGH
0	1	CLK1, nCLK1	Disabled; LOW	Disabled; HIGH
1	0	CLK0, nCLK0	Enabled	Enabled
1	1	CLK1, nCLK1	Enabled	Enabled

After CLK_EN switches, the clock outputs are disabled or enabled following a rising and falling input clock edge as shown in Figure 1.

In the active mode, the state of the outputs are a function of the CLK0, nCLK0 and CLK1, nCLK1 inputs as described in Table 3B.

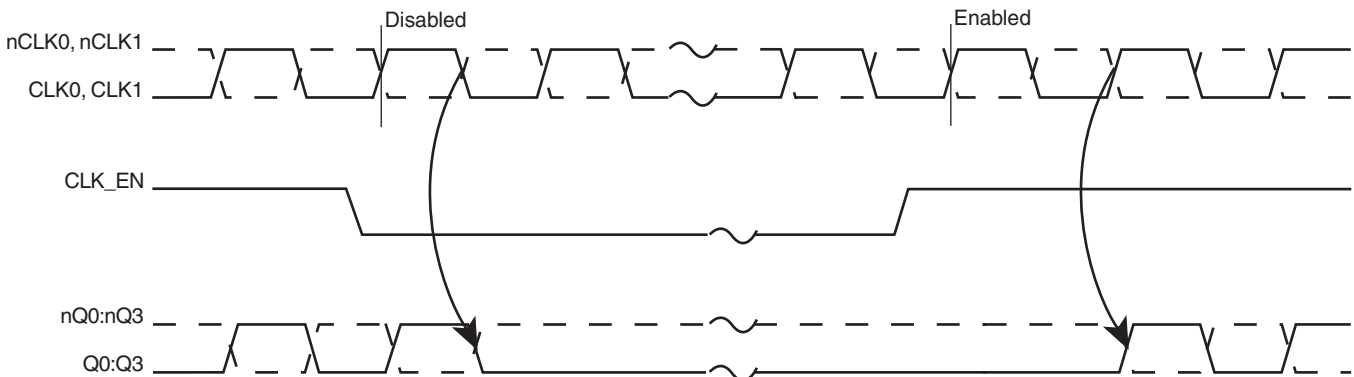

FIGURE 1. CLK_EN TIMING DIAGRAM

TABLE 3B. CLOCK INPUT FUNCTION TABLE

Inputs		Outputs		Input to Output Mode	Polarity
CLK0 or CLK1	nCLK0 or nCLK1	Q0:Q3	nQ0:nQ3		
0	0	LOW	HIGH	Differential to Differential	Non Inverting
1	1	HIGH	LOW	Differential to Differential	Non Inverting
0	Biased; NOTE 1	LOW	HIGH	Single Ended to Differential	Non Inverting
1	Biased; NOTE 1	HIGH	LOW	Single Ended to Differential	Non Inverting
Biased; NOTE 1	0	HIGH	LOW	Single Ended to Differential	Inverting
Biased; NOTE 1	1	LOW	HIGH	Single Ended to Differential	Inverting

NOTE 1: Please refer to the Application Information section, "Wiring the Differential Input to Accept Single Ended Levels".



ABSOLUTE MAXIMUM RATINGS

Supply Voltage, V_{CC}	4.6V
Inputs, V_i	-0.5V to $V_{CC} + 0.5V$
Outputs, I_o	
Continuous Current	50mA
Surge Current	100mA
Package Thermal Impedance, θ_{JA}	73.2°C/W (0 lfpm)
Storage Temperature, T_{STG}	-65°C to 150°C

NOTE: Stresses beyond those listed under Absolute Maximum Ratings may cause permanent damage to the device. These ratings are stress specifications only. Functional operation of product at these conditions or any conditions beyond those listed in the *DC Characteristics* or *AC Characteristics* is not implied. Exposure to absolute maximum rating conditions for extended periods may affect product reliability.

TABLE 4A. POWER SUPPLY DC CHARACTERISTICS, $V_{DD} = 3.3V \pm 5\%$, $V_{DDO} = 1.8V \pm 0.2V$, $T_A = -40^\circ C$ TO $85^\circ C$

Symbol	Parameter	Test Conditions	Minimum	Typical	Maximum	Units
V_{DD}	Core Supply Voltage		3.135	3.3	3.465	V
V_{DDO}	Output Power Supply Voltage		1.6	1.8	2.0	V
I_{DD}	Power Supply Current				55	mA

TABLE 4B. LVCMOS / LVTTTL DC CHARACTERISTICS, $V_{DD} = 3.3V \pm 5\%$, $V_{DDO} = 1.8V \pm 0.2V$, $T_A = -40^\circ C$ TO $85^\circ C$

Symbol	Parameter	Test Conditions	Minimum	Typical	Maximum	Units
V_{IH}	Input High Voltage	CLK_EN, CLK_SEL	2		$V_{DD} + 0.3$	V
V_{IL}	Input Low Voltage	CLK_EN, CLK_SEL	-0.3		0.8	V
I_{IH}	Input High Current	CLK_EN	$V_{DD} = V_{IN} = 3.465V$		5	μA
		CLK_SEL	$V_{DD} = V_{IN} = 3.465V$		150	μA
I_{IL}	Input Low Current	CLK_EN	$V_{DD} = 3.465V, V_{IN} = 0V$	-150		μA
		CLK_SEL	$V_{DD} = 3.465V, V_{IN} = 0V$	-5		μA

TABLE 4C. DIFFERENTIAL DC CHARACTERISTICS, $V_{DD} = 3.3V \pm 5\%$, $V_{DDO} = 1.8V \pm 0.2V$, $T_A = -40^\circ C$ TO $85^\circ C$

Symbol	Parameter	Test Conditions	Minimum	Typical	Maximum	Units
I_{IH}	Input High Current	nCLK0, nCLK1	$V_{DD} = V_{IN} = 3.465V$		5	μA
		CLK0, CLK1	$V_{DD} = V_{IN} = 3.465V$		150	μA
I_{IL}	Input Low Current	nCLK0, nCLK1	$V_{DD} = 3.465V, V_{IN} = 0V$	-150		μA
		CLK0, CLK1	$V_{DD} = 3.465V, V_{IN} = 0V$	-5		μA
V_{PP}	Peak-to-Peak Input Voltage		0.15		1.3	V
V_{CMR}	Common Mode Input Voltage; NOTE 1, 2		0.5		$V_{DD} - 0.85$	V

NOTE 1: For single ended applications the maximum input voltage for CLK0, nCLK0 and CLK1, nCLK1 is $V_{DD} + 0.3V$.

NOTE 2: Common mode voltage is defined as V_{IH} .

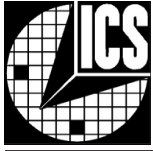

TABLE 4D. LVHSTL DC CHARACTERISTICS, $V_{DD} = 3.3V \pm 5\%$, $V_{DDO} = 1.8V \pm 0.2V$, $T_A = -40^\circ C$ TO $85^\circ C$

Symbol	Parameter	Test Conditions	Minimum	Typical	Maximum	Units
V_{OH}	Output High Voltage; NOTE 1		0.7		1.0	V
V_{OL}	Output Low Voltage; NOTE 1		0		0.4	V
V_{SWING}	Peak-to-Peak Output Voltage Swing		0.4		1.0	V

NOTE 1: Outputs terminated with 50Ω to ground.

TABLE 5. AC CHARACTERISTICS, $V_{DD} = 3.3V \pm 5\%$, $V_{DDO} = 1.8V \pm 0.2V$, $T_A = -40^\circ C$ TO $85^\circ C$

Symbol	Parameter	Test Conditions	Minimum	Typical	Maximum	Units
f_{MAX}	Maximum Output Frequency				650	MHz
t_{PD}	Propagation Delay; NOTE 1	$f \leq 650MHz$	0.9	1.2	1.5	ns
$tsk(o)$	Output Skew; NOTE 2, 4				50	ps
$tsk(pp)$	Part-to-Part Skew; NOTE 3, 4				400	ps
t_R / t_F	Output Rise/Fall Time	20% to 80%	150		500	ps
odc	Output Duty Cycle	$f > 200MHz$	45	50	55	%
		$f \leq 200MHz$	48		52	%

All parameters measured at 500MHz unless noted otherwise.

The cycle to cycle jitter on the input will equal the jitter on the output. The part does not add jitter.

NOTE 1: Measured from the differential input crossing point to the differential output crossing point.

NOTE 2: Defined as skew between outputs at the same supply voltage and with equal load conditions. Measured at output differential cross points.

NOTE 3: Defined as skew between outputs on different devices operating at the same supply voltages and with equal load conditions. Using the same type of inputs on each device, the outputs are measured at the differential cross points.

NOTE 4: This parameter is defined in accordance with JEDEC Standard 65.

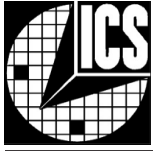

PARAMETER MEASUREMENT INFORMATION

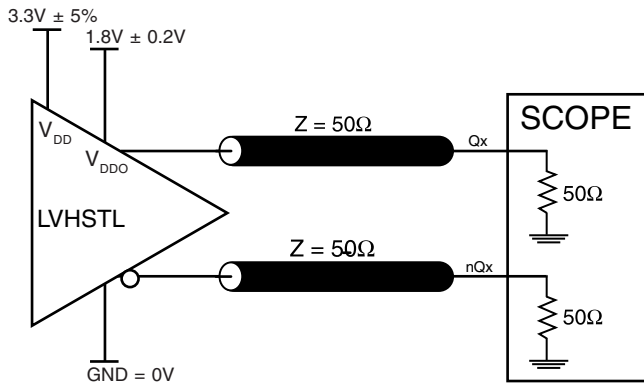

3.3V CORE/1.8V OUTPUT LOAD AC TEST CIRCUIT

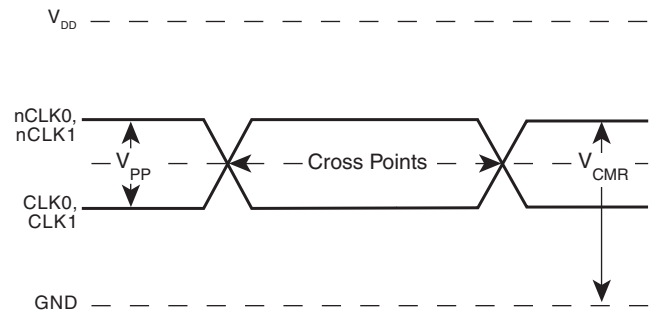

DIFFERENTIAL INPUT LEVEL

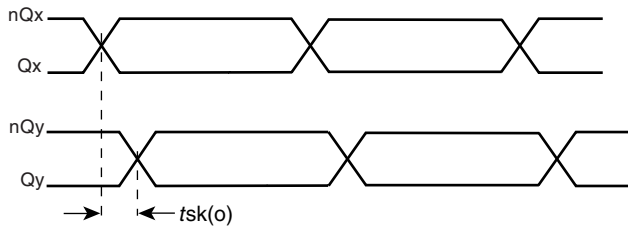

OUTPUT SKEW

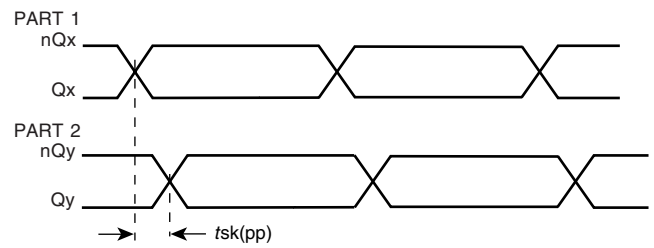

PART-TO-PART SKEW

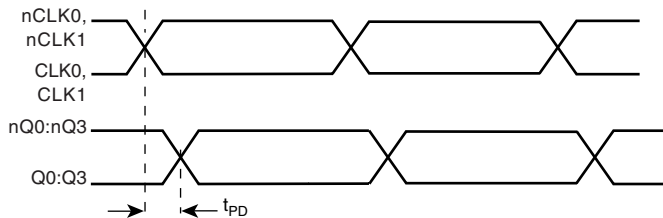

PROPAGATION DELAY

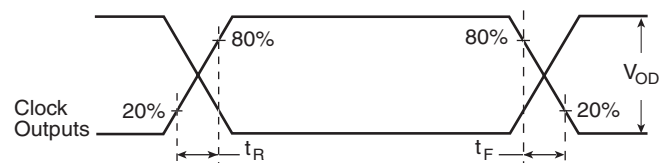

OUTPUT RISE/FALL TIME

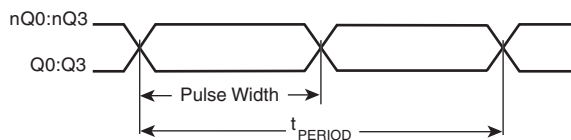

$$odc = \frac{t_{PW}}{t_{PERIOD}}$$

OUTPUT DUTY CYCLE/PULSE WIDTH/PERIOD

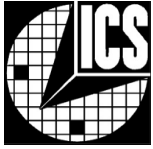

APPLICATION INFORMATION

WIRING THE DIFFERENTIAL INPUT TO ACCEPT SINGLE ENDED LEVELS

Figure 2 shows how the differential input can be wired to accept single ended levels. The reference voltage $V_{REF} = V_{DD}/2$ is generated by the bias resistors R1, R2 and C1. This bias circuit should be located as close as possible to the input pin.

of R1 and R2 might need to be adjusted to position the V_{REF} in the center of the input voltage swing. For example, if the input clock swing is only 2.5V and $V_{DD} = 3.3V$, V_{REF} should be 1.25V and $R2/R1 = 0.609$.

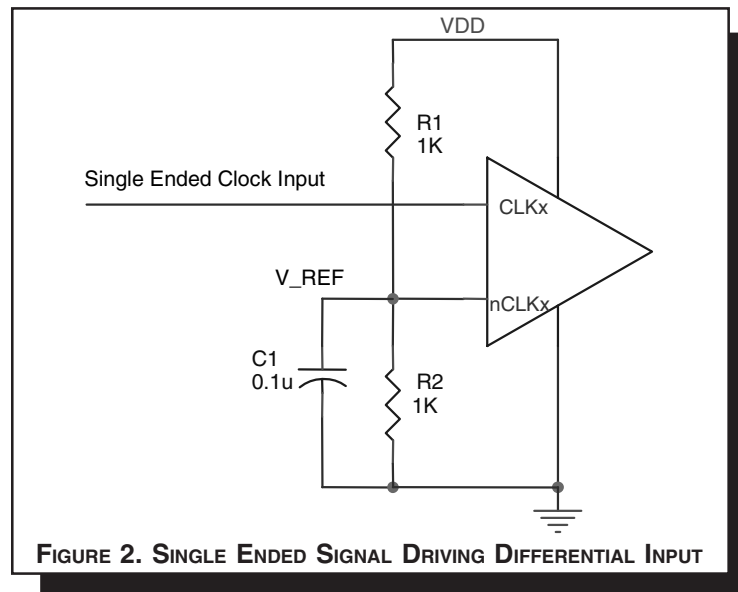
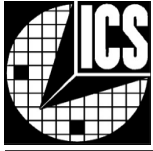

FIGURE 2. SINGLE ENDED SIGNAL DRIVING DIFFERENTIAL INPUT



DIFFERENTIAL CLOCK INPUT INTERFACE

The CLK/nCLK accepts LVDS, LVPECL, LVHSTL, SSTL, HCSTL and other differential signals. Both V_{SWING} and V_{OH} must meet the V_{PP} and V_{CMR} input requirements. Figures 3A to 3E show interface examples for the HiPerClockS CLK/nCLK input driven by the most common driver types. The input interfaces suggested

here are examples only. Please consult with the vendor of the driver component to confirm the driver termination requirements. For example in *Figure 4A*, the input termination applies for ICS HiPerClockS LVHSTL drivers. If you are using an LVHSTL driver from another vendor, use their termination recommendation.

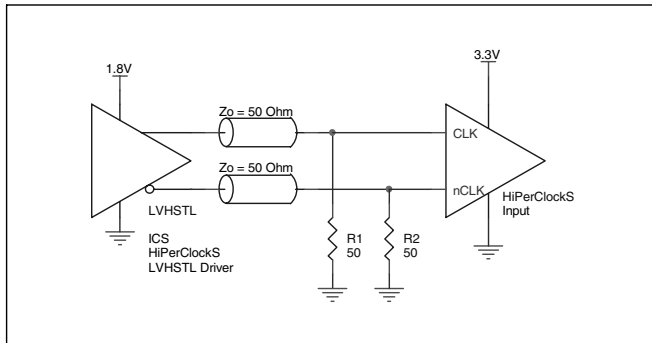

FIGURE 3A. HiPerClockS CLK/nCLK INPUT DRIVEN BY ICS HiPerClockS LVHSTL DRIVER

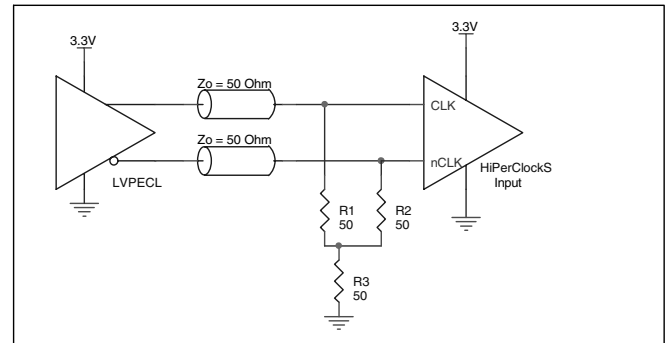

FIGURE 3B. HiPerClockS CLK/nCLK INPUT DRIVEN BY 3.3V LVPECL DRIVER

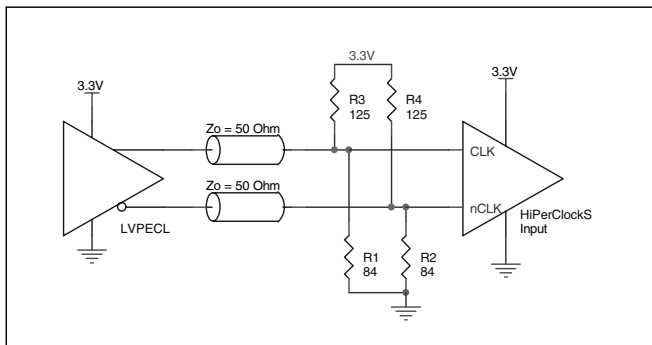

FIGURE 3C. HiPerClockS CLK/nCLK INPUT DRIVEN BY 3.3V LVPECL DRIVER

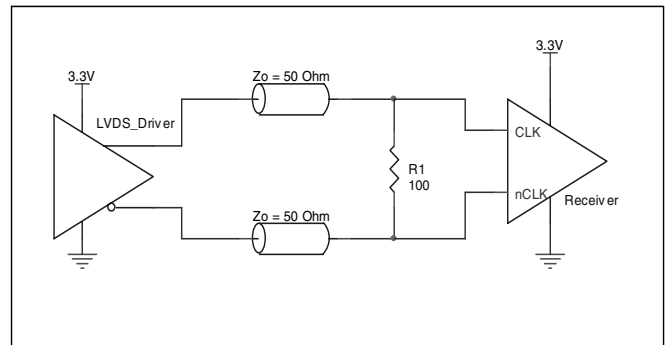

FIGURE 3D. HiPerClockS CLK/nCLK INPUT DRIVEN BY 3.3V LVDS DRIVER

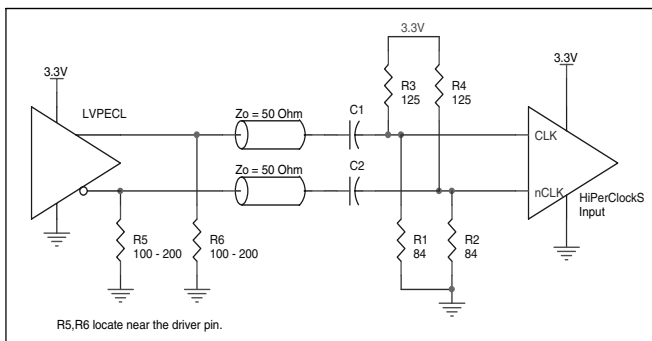
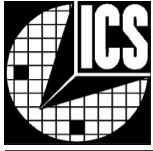

FIGURE 3E. HiPerClockS CLK/nCLK INPUT DRIVEN BY 3.3V LVPECL DRIVER WITH AC COUPLE



SCHEMATIC EXAMPLE

This application note provides general design guide using ICS8523I-03 LVHSTL buffer. Figure 3 shows a schematic example of the ICS8523I-03 LVHSTL Clock buffer. In this example,

the input is driven by an LVHSTL driver. CLK_EN is set at logic low to select CLK0/nCLK0 input.

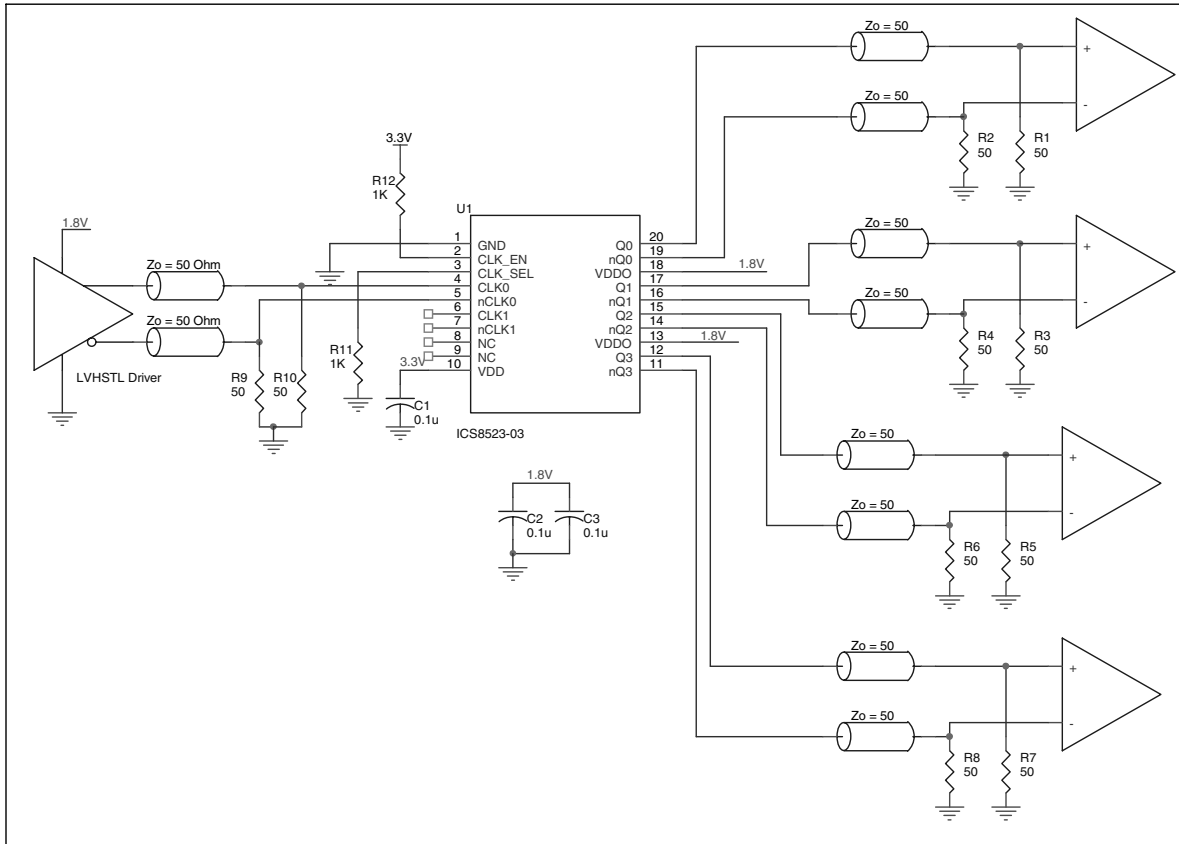
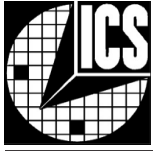

FIGURE 4. EXAMPLE ICS8523I-03 LVHSTL CLOCK OUTPUT BUFFER SCHEMATIC



POWER CONSIDERATIONS

This section provides information on power dissipation and junction temperature for the ICS8523I-03. Equations and example calculations are also provided.

1. Power Dissipation.

The total power dissipation for the ICS8523I-03 is the sum of the core power plus the power dissipated in the load(s). The following is the power dissipation for $V_{DD} = 3.3V + 5\% = 3.465V$, which gives worst case results.

NOTE: Please refer to Section 3 for details on calculating power dissipated in the load.

- Power (core)_{MAX} = $V_{DD_MAX} * I_{DD_MAX} = 3.465V * 55mA = 190mW$
- Power (outputs)_{MAX} = **32.8mW/Loaded Output pair**
If all outputs are loaded, the total power is $4 * 32.8mW = 131mW$

Total Power_{MAX} (3.465V, with all outputs switching) = $190mW + 131mW = 321mW$

2. Junction Temperature.

Junction temperature, T_j , is the temperature at the junction of the bond wire and bond pad and directly affects the reliability of the device. The maximum recommended junction temperature for HiPerClockS™ devices is 125°C.

The equation for T_j is as follows: $T_j = \theta_{JA} * Pd_total + T_A$

T_j = Junction Temperature

θ_{JA} = Junction-to-Ambient Thermal Resistance

Pd_total = Total Device Power Dissipation (example calculation is in section 1 above)

T_A = Ambient Temperature

In order to calculate junction temperature, the appropriate junction-to-ambient thermal resistance θ_{JA} must be used. Assuming a moderate air flow of 200 linear feet per minute and a multi-layer board, the appropriate value is 66.6°C/W per Table 6 below. Therefore, T_j for an ambient temperature of 85°C with all outputs switching is:

$85^\circ C + 0.321W * 66.6^\circ C/W = 106.4^\circ C$. This is well below the limit of 125°C.

This calculation is only an example. T_j will obviously vary depending on the number of loaded outputs, supply voltage, air flow, and the type of board (single layer or multi-layer).

TABLE 6. THERMAL RESISTANCE θ_{JA} FOR 20-PIN TSSOP, FORCED CONVECTION

θ_{JA} by Velocity (Linear Feet per Minute)			
	0	200	500
Single-Layer PCB, JEDEC Standard Test Boards	114.5°C/W	98.0°C/W	88.0°C/W
Multi-Layer PCB, JEDEC Standard Test Boards	73.2°C/W	66.6°C/W	63.5°C/W

NOTE: Most modern PCB designs use multi-layered boards. The data in the second row pertains to most designs.



3. Calculations and Equations.

The purpose of this section is to derive the power dissipated into the load.

LVHSTL output driver circuit and termination are shown in *Figure 5*.

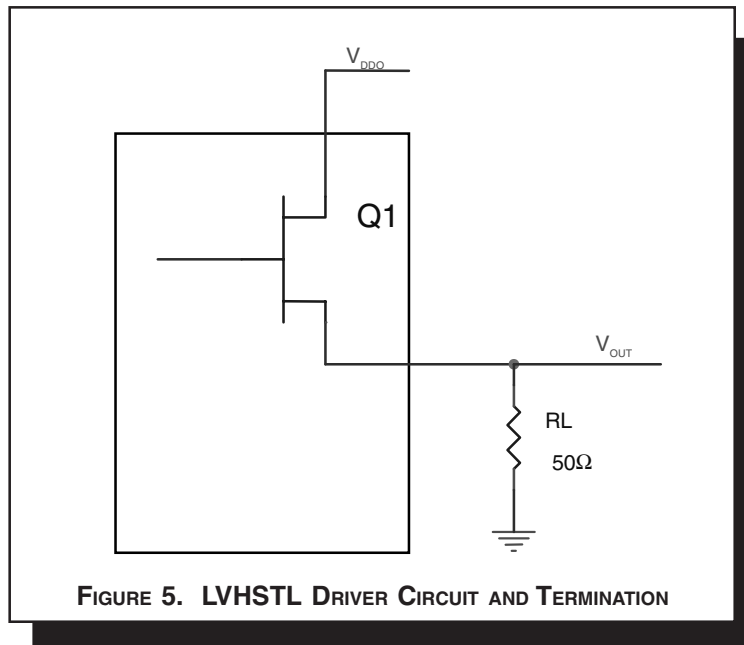

To calculate worst case power dissipation into the load, use the following equations which assume a 50Ω load.

Pd_H is power dissipation when the output drives high.

Pd_L is the power dissipation when the output drives low.

$$Pd_H = (V_{OH_MAX} / R_L) * (V_{DDO_MAX} - V_{OH_MAX})$$

$$Pd_L = (V_{OL_MAX} / R_L) * (V_{DDO_MAX} - V_{OL_MAX})$$

$$Pd_H = (1V/50\Omega) * (2V - 1V) = \mathbf{20mW}$$

$$Pd_L = (0.4V/50\Omega) * (2V - 0.4V) = \mathbf{12.8mW}$$

$$\text{Total Power Dissipation per output pair} = Pd_H + Pd_L = \mathbf{32.8mW}$$



RELIABILITY INFORMATION

TABLE 7. θ_{JA} VS. AIR FLOW TABLE FOR 20 LEAD TSSOP

θ_{JA} by Velocity (Linear Feet per Minute)			
	0	200	500
Single-Layer PCB, JEDEC Standard Test Boards	114.5°C/W	98.0°C/W	88.0°C/W
Multi-Layer PCB, JEDEC Standard Test Boards	73.2°C/W	66.6°C/W	63.5°C/W

NOTE: Most modern PCB designs use multi-layered boards. The data in the second row pertains to most designs.

TRANSISTOR COUNT

The transistor count for ICS8523I-03 is: 472

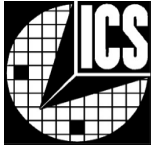

PACKAGE OUTLINE - G SUFFIX FOR 20 LEAD TSSOP

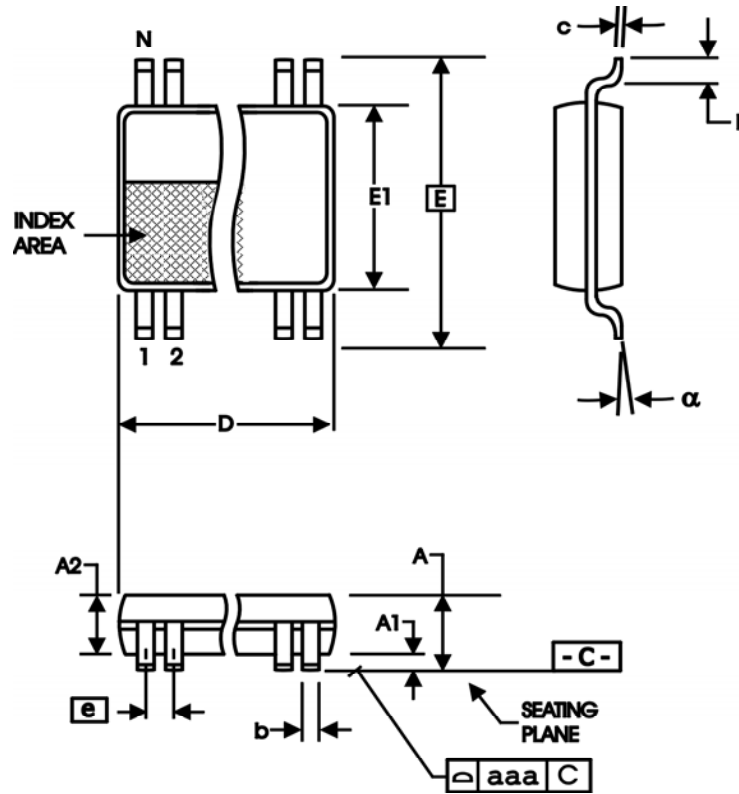
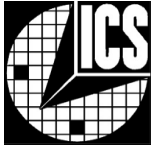

TABLE 8. PACKAGE DIMENSIONS

SYMBOL	Millimeters	
	Minimum	Maximum
N	20	
A	--	1.20
A1	0.05	0.15
A2	0.80	1.05
b	0.19	0.30
c	0.09	0.20
D	6.40	6.60
E	6.40 BASIC	
E1	4.30	4.50
e	0.65 BASIC	
L	0.45	0.75
alpha	0°	8°
aaa	--	0.10

Reference Document: JEDEC Publication 95, MS-153



Integrated
Circuit
Systems, Inc.

ICS8523I-03

LOW SKEW, 1-TO-4 DIFFERENTIAL-TO-LVHSTL FANOUT BUFFER

TABLE 9. ORDERING INFORMATION

Part/Order Number	Marking	Package	Count	Temperature
ICS8523AGI-03	ICS8523AGI03	20 lead TSSOP	72 per tube	-40°C to 85°C
ICS8523AGI-03T	ICS8523AGI03	20 lead TSSOP on Tape and Reel	2500	-40°C to 85°C
ICS8523AGI-03LF	ICS8523AI03L	20 lead "Lead-Free" TSSOP	72 per tube	-40°C to 85°C
ICS8523AGI-03LFT	ICS8523AI03L	20 lead "Lead-Free" TSSOP on Tape and Reel	2500	-40°C to 85°C

The aforementioned trademark, HiPerClockS™ is a trademark of Integrated Circuit Systems, Inc. or its subsidiaries in the United States and/or other countries.

While the information presented herein has been checked for both accuracy and reliability, Integrated Circuit Systems, Incorporated (ICS) assumes no responsibility for either its use or for infringement of any patents or other rights of third parties, which would result from its use. No other circuits, patents, or licenses are implied. This product is intended for use in normal commercial and industrial applications. Any other applications such as those requiring high reliability or other extraordinary environmental requirements are not recommended without additional processing by ICS. ICS reserves the right to change any circuitry or specifications without notice. ICS does not authorize or warrant any ICS product for use in life support devices or critical medical instruments.



Integrated
Circuit
Systems, Inc.

ICS8523I-03
LOW SKEW, 1-TO-4
DIFFERENTIAL-TO-LVHSTL FANOUT BUFFER

REVISION HISTORY SHEET				
Rev	Table	Page	Description of Change	Date
A	T9	1	Features section - added Lead-Free bullet.	9/13/04
		8	Updated Differential Clock Input Interface section and deleted LVPECL Clock Input Interface section.	
		14	Added Lead-Free marking to Ordering Information table.	