

ADVANCE INFORMATION

Features

- Pre-Programmed to Decode all Major Two-Tone, 5/6-Tone and HSC Tonesets
- Low Power: 0.5mA at 2.7V typically
- Superior Signal to Noise Performance
- Low Cost 3.58MHz Xtal/Clock
- μ C Serial Interface + TSSOP Package

Applications

- Two-Tone and 5/6-Tone Pagers
- Selective Calling (SELCALL) Systems
- Voice Pager Switching and Signaling
- Revertive Paging Systems
- Wireless Local Loop Signaling
- Audio Tone Signaling Applications

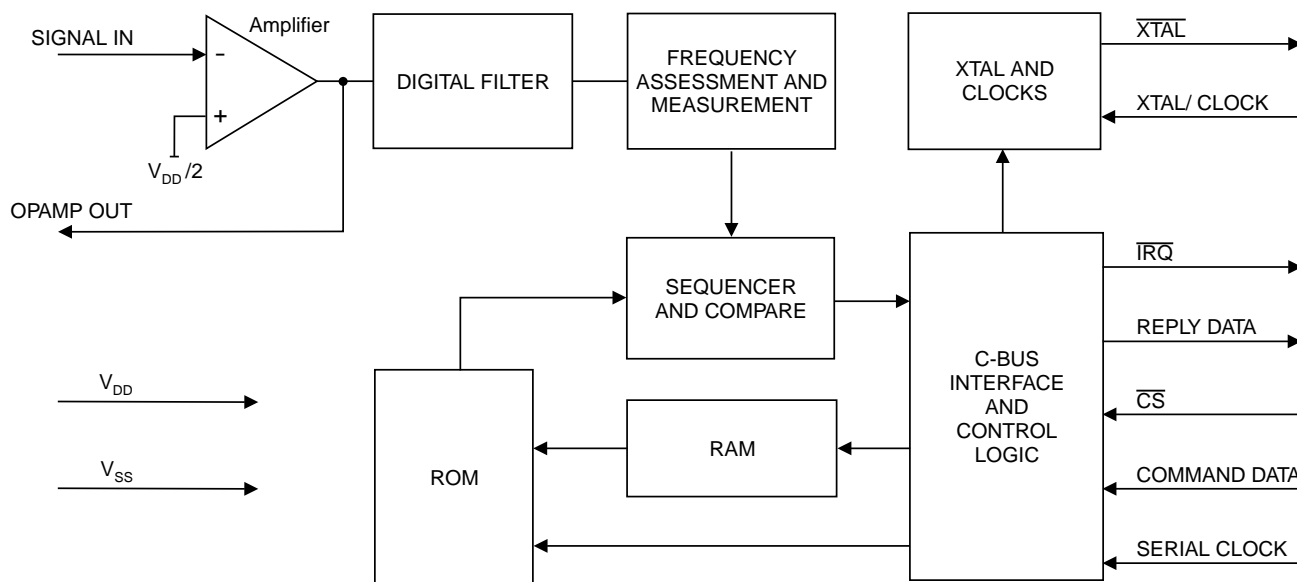

The CMX813 decodes the signaling tones for the Motorola Quick Call series, GE groups A, B and C and the tonesets employed by the Zetron, Reach and Plectron 2-tone radio paging systems. It also decodes the tones for Motorola 5/6-tone paging and the EIA, CCIR, ZVEI1 and EEA tonesets used for HSC radio paging and SELCALL. A simple serial interface allows the host μ C to specify the individual tone(s), or group of tones, to be decoded from the extensive list held by the CMX813.

When the μ C receives an $\overline{\text{IRQ}}$ it examines the STATUS and DECODED TONE ADDRESS Registers to reveal the tone decoded. In 2-tone mode, the CMX813 will report which of the (up to eight) selected tones it has decoded. This report is an 8-bit index number to the tone in the programmed list. For 5/6-tone or HSC groups, the CMX813 will report which tone in the selected system toneset (e.g. CCIR, EIA) has been decoded, as a 4-bit hexadecimal tone value within the selected group.

To allow for cadence measurements, the $\overline{\text{IRQ}}$ is activated again when the tone is no longer present. A status value of "No-tone" is returned. The CMX813 is designed to operate over a wide temperature range with a typical operating current of 0.5mA at 2.7Volts. It also has a Zero-Power mode and is available in 16-pin TSSOP (CMX813E4) and 16-pin DIP (CMX813P3) packages.

CONTENTS

Section	Page
1. Block Diagram	3
2. Signal List	4
3. External Components	5
4. General Description	5
5. Software Description	6
5.1 Address/Commands	6
5.1.1 8-bit Write Only Registers	6
5.1.2 Write Only Register Description.....	6
5.1.3 8-bit Read Only Registers.....	8
5.1.4 Read Only Register Description	8
6. Application Notes.....	9
6.1 General.....	9
6.2 Tone Tables.....	10
7. Performance Specification	16
7.1 Electrical Performance.....	16
7.1.1 Absolute Maximum Ratings	16
7.1.2 Operating Limits.....	16
7.1.3 1.7.1.3 Operating Characteristics	17
7.1.4 Timing	18
7.2 Packaging.....	19

MXCOM, Inc. reserves the right to change specifications at any time and without notice.

1. Block Diagram

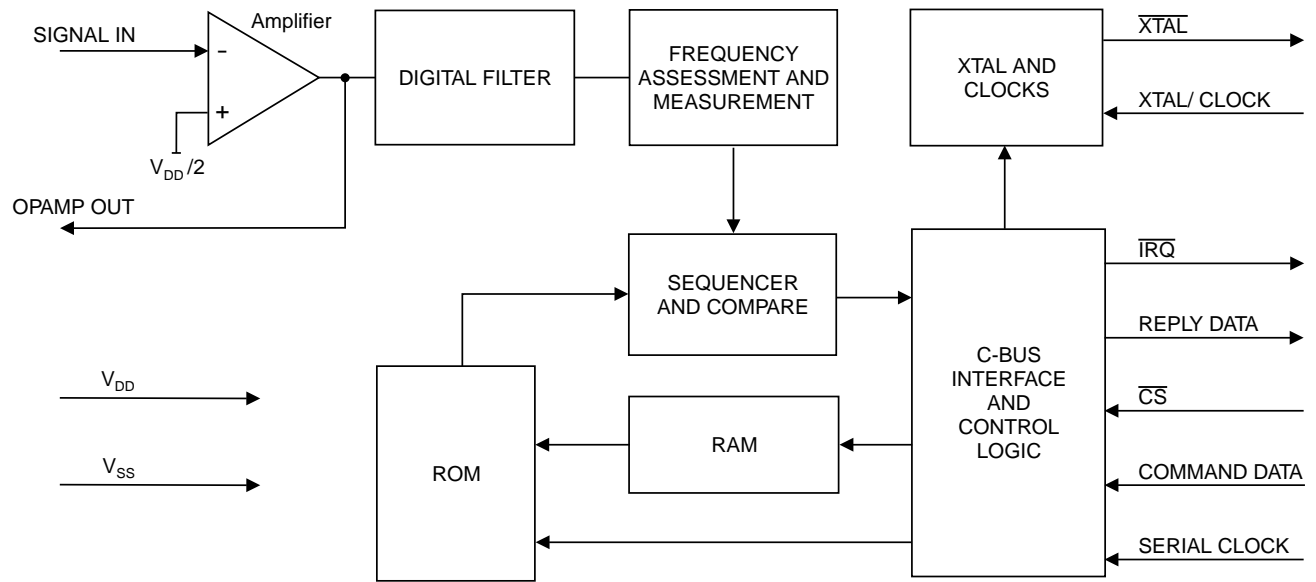

Figure 1: Block Diagram

2. Signal List

Package	Signal		Description
Pin No. E4/P3	Name	Type	
1	SERIAL CLOCK	input	The C-BUS serial clock input. This clock, produced by the μ Controller, is used for transfer timing of commands and data to and from the device. See Figure 3.
2	COMMAND DATA	input	The C-BUS serial data input from the μ Controller. Data is loaded into this device in 8-bit bytes, MSB (D7) first, and LSB (D0) last, synchronized to the SERIAL CLOCK. See Figure 3.
3	REPLY DATA	output	The C-BUS serial data output to the μ Controller. The transmission of REPLY DATA bytes is synchronized to the SERIAL CLOCK under the control of the \overline{CS} input. This 3-state output is held at high impedance when not sending data to the μ Controller. See Figure 3.
4	\overline{CS}	input	The C-BUS data loading control function: this input is provided by the μ Controller. Data transfer sequences are initiated, completed or aborted by the \overline{CS} signal. See Figure 3.
5	\overline{IRQ}	output	This output indicates an interrupt condition to the μ Controller by going to a logic "0". This is a "wire-ORable" output; enabling the connection of up to 8 peripherals to 1 interrupt port on the μ Controller. This pin has a low impedance pull-down to logic "0" when active and a high-impedance when inactive. An external pull-up resistor is required. An interrupt is effective if not masked out by the IRQ MASK (bit 0 in the SUB-AUDIO CONTROL register \$80).
6	NC		Reserved for future use. Do not make any connection to this pin.
7	NC		For manufacturer's use only. Connect to V_{SS} .
8	V_{SS}	power	The negative supply rail (ground).
9	SIGNAL IN	input	The inverting input to the input amplifier.
10	OPAMP OUT	output	The output of the input amplifier and the input to the Digital filter section.
11	NC		Reserved for future use. Do not make any connection to these pins.
12	NC		
13	NC		
14	XTAL	input	The input of the on-chip oscillator.
15	\overline{XTAL}	output	The inverted output of the on-chip oscillator.
16	V_{DD}	power	The positive supply rail. Levels and voltages are dependent upon this supply. This pin should be decoupled to V_{SS} by a capacitor.

Table 1: Signal List

3. External Components

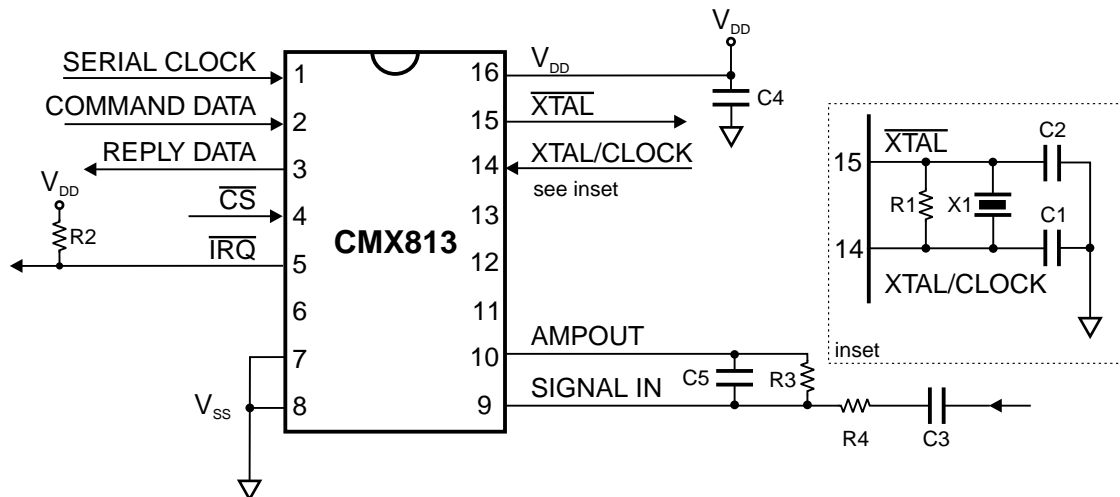

Figure 2: Recommended External Components

C1	18pF	±20%	R1	1MΩ	±5%
C2	18pF	±20%	R2	22kΩ	±10%
C3	68nF	±20%	R3	1MΩ	±10%
C4	0.1μF	±20%	R4	51kΩ	±10%
C5	22pF	±20%	X1	3.5795450MHz	±100ppm

Table 2: Recommended External Components

4. General Description

When the CMX813 detects the start of a tone, it generates an interrupt and reports which tone was detected. At the end of the tone, it will produce an interrupt and report Notone detected. The host micro should measure and interpret the tone lengths and gap lengths according to calling code requirements. The device is not designed for the decoding of multiple tones that are present simultaneously.

In 2-tone mode, the parameters for decoding each tone in the tone table are stored in a decoding ROM, and any one of these tones can be selected for decoding via an 8-bit ROM address. Up to eight 8-bit ROM addresses can be selected by the host micro for decoding. These are held in an internal address RAM which downloads the addresses sequentially to the ROM and retrieves the tone decode parameters and matches these with the received signal to find a tone decode. If a match is found, the CMX813 generates an interrupt and reports the decoded tone table ROM address. The device can therefore decode any number of single or 2-tone pager codes, formed by any combination of up to 8 different frequencies, received in any order.

In 5/6 tone and HSC modes, the tone parameters are stored in ROM in groups of 16 tones in accordance with the various international tonesets (CCIR/ZVEI etc.). Any one of these groups can be selected for decoding at any time. ROM address sequencing is automatic. When any one of the 16 tones in that group is decoded, the device interrupts and reports the group and tone number of the tone (8 bits).

The input amplifier with suitable external components is used to adjust the received signal to the correct amplitude for the decoder. All functions are controlled over a C-BUS serial μC interface.

5. Software Description

5.1 Address/Commands

Instructions and data are transferred, via C-BUS, in accordance with the timing information provided in Figure 3.

Instruction and data transactions to and from the CMX813 consist of an Address/Command (A/C) byte, which may be followed by either:

- (i) a further instruction or data (1 byte) or
- (ii) a status or Rx data reply (1 byte)

5.1.1 8-bit Write Only Registers

HEX ADDRESS/COMMAND	REGISTER NAME	BIT 7 (D7)	BIT 6 (D6)	BIT 5 (D5)	BIT 4 (D4)	BIT 3 (D3)	BIT 2 (D2)	BIT 1 (D1)	BIT 0 (D0)	
\$01	GENERAL RESET	N/A	N/A	N/A	N/A	N/A	N/A	N/A	N/A	
\$30	CONTROL	ROM PAGE SELECT		DECODER BANDWIDTH				OPERATION MODE		
		MSB	LSB	MSB		LSB		MSB	LSB	
		BIT 7	BIT 6	BIT 5	BIT 4	BIT 3	BIT 2	BIT 1	BIT 0	
\$31	TONE ADDRESS	TONE ADDRESS								
		MSB								LSB
		BIT 7	BIT 6	BIT 5	BIT 4	BIT 3	BIT 2	BIT 1	BIT 0	

5.1.2 Write Only Register Description

5.1.2.1 GENERAL RESET (Hex address \$01)

The reset command has no data attached to it. It sets the device (write) registers to zero and enters the Zero Power mode. And all RAM contents and RAM FULL bit of the STATUS Register are reset to 0.

5.1.2.2 CONTROL Register (Hex address \$30)

This register is used to control the functions of the device as described below:

ROM PAGE SELECT (Bits 7 and 6)	These two bits select the section of the ROM where pre-programmed tone data are stored for detection. The ROM area is divided into three sections (pages). The 1 tone or 2 tone system tones are stored in ROM Page 1 and 2. The 5/6 tone and HSC tones are stored in ROM Page 3.
DECODER BANDWIDTH (Bits 5, 4, 3 and 2)	These four bits set the bandwidth of the tone decoder according to table below:
OPERATION MODE (Bits 1 and 0)	These two bits select the mode of operation of the device.

Bit 7	Bit 6	ROM PAGE
0	0	No ROM PAGE selected, a valid but unrecognized tone may be detected, no interrupt generated
0	1	ROM Page 1 selected, for 1 tone or 2 tone system
1	0	ROM Page 2 selected, for 1 tone or 2 tone system
1	1	ROM Page 3 selected, for 5/6 tone or HSC tone system

Table 3: ROM PAGE SELECT (Bits 7 and 6)

Bit 5	Bit 4	Bit 3	Bit 2	BANDWIDTH
				Nominal Decode
0	0	0	0	±0.1%
0	0	0	1	±0.3%
0	0	1	0	±0.5%
0	0	1	1	±0.7%
0	1	0	0	±0.9%
0	1	0	1	±1.1%
0	1	1	0	±1.3%
0	1	1	1	±1.5%
1	0	0	0	±1.7%
1	0	0	1	±1.9%
1	0	1	0	±2.1%
1	0	1	1	±2.3%
1	1	0	0	±2.5%
1	1	0	1	±2.7%
1	1	1	0	±2.9%
1	1	1	1	±3.1%

Table 4: DECODER BANDWIDTH (Bits 5,4,3,and 2)

Bit 1	Bit 0	OPERATION MODE
0	0	Zero Power
0	1	Clear RAM, all RAM contents and RAM FULL bit of the STATUS Register are reset to 0.
1	0	Normal operation, decode enabled
1	1	Reserved

Table 5: OPERATION MODE (Bits 1 and 0)

5.1.2.3 TONE ADDRESS Register (Hex address \$31)

This register is used to load ROM addresses to the internal RAM for decode as described below:

TONE ADDRESS (Bits 7, 6, 5, 4, 3, 2, 1, and 0)	<p>The parameters (center frequency) for decoding each tone in the tone table are stored in a decoding ROM, and any one of these tones can be selected for decoding via this 8-bit ROM address. The tones table and address allocations are listed in the Application Notes, Section 6.</p> <p>For a 1-tone or 2-tone system, up to eight ROM addresses can be loaded to the RAM for decode from a chosen ROM page. A FIFO system is used for loading the RAM memory. If more than 8 ROM addresses were loaded to the RAM, only the last 8 entries will be stored.</p> <p>For the 5/6 tone and HSC tone system, Bits 7, 6, 5, and 4 are used to select a specific tone set (CCIR/ZVEI etc.) for decode. The decode algorithm will search automatically through the sixteen ROM addresses associated with the chosen tone set.</p> <p>Bits 3, 2, 1, and 0 are not used and should be set to 0.</p>
---	---

5.1.3 8-bit Read Only Registers

HEX ADDRESS/COMMAND	REGISTER NAME	BIT 7 (D7)	BIT 6 (D6)	BIT 5 (D5)	BIT 4 (D4)	BIT 3 (D3)	BIT 2 (D2)	BIT 1 (D1)	BIT 0 (D0)
\$38	DECODED TONE ADDRESS	DECODED TONE ADDRESS							
		MSB BIT 7	BIT 6	BIT 5	BIT 4	BIT 3	BIT 2	BIT 1	LSB BIT 0
\$3F	STATUS	Reserved set to			RAM FULL	DECODE STATUS CHANGE	TONE DECODE	DECODED ROM PAGE	
		1	1	0				MSB BIT 1	LSB BIT 0

5.1.4 Read Only Register Description

5.1.4.1 DECODED TONE ADDRESS Register (Hex address \$38)

This register is used to send the decoded ROM addresses to the host micro as described below:

DECODED TONE ADDRESS (Bits 7, 6, 5, 4, 3, 2, 1, and 0)	<p>When a tone is decoded, the CMX813 generates an interrupt and reports the decoded tone table 8-bit ROM address. The tone table and address allocations are listed in the Application Notes, Section 1.6.</p> <p>For the 1-tone or 2-tone system, the 8-bit ROM address is located either from ROM PAGE 1 or 2.</p> <p>For the 5/6 tone and HSC tones system, Bits 7, 6, 5, and 4 represent the selected tone set (CCIR/ZVEI etc), Bits 3, 2, 1, and 0 are the 4 bit Hexadecimal tone value within the selected group. This is located in ROM PAGE 3.</p>
--	---

5.1.4.2 STATUS Register (Hex address \$3F)

This register is used to indicate the status of the device as described below:

(Bits 7, 6 and 5)	Reserved for future use. These will be set to "110" respectively but should be ignored by user's software.
RAM FULL (Bit 4)	After eight tone addresses are loaded to the RAM for tones located in ROM PAGE 1 or 2, this bit is set to '1'. A Clear RAM command will reset it to '0'.
DECODE STATUS CHANGE (Bit 3)	When TONE DECODE (Bit 2 of this register) or the decoded 8 bit address in DECODED TONE ADDRESS Register \$38 changes state this bit will be set to "1". A "0" indicates no decode status change.
TONE DECODE (Bit 2)	<p>This bit indicates the status of the tone decoder. A "1" indicates a tone has been detected (TONE DECODE) and a "0" indicates the loss of the tone (NOTONE). TONE DECODE means that a tone has been decoded and its characteristics are as defined by the bandwidth (see CONTROL Register \$30, Bits 5, 4, 3 and 2) and the center frequency (see TONE ADDRESS Register \$31, Bit 7 to Bit 0). When Bit 7 and Bit 6 in the CONTROL Register \$30 are set to "0" the TONE DECODE Bit 2 will be set to "0".</p> <p>From NOTONE state, identification of a valid tone which is not in the pre-programmed list (up to eight tones in 1 or 2 tone system and 16 tones in 5/6 tone or HSC) will cause the decoder to move to the TONE DECODE state with the DECODED ROM PAGE address of "00" in Bits 1 and 0; indicating a valid but unrecognized tone. No interrupt is generated.</p> <p>Loss of tone will cause the NOTONE timer to be started. If loss of tone continues for the duration of the time-out period, then the decoder will move to the NOTONE state and the identification of pre-programmed tones will start again. The time-out period is not user adjustable.</p>
DECODED ROM PAGE (Bits 1 and 0)	These two bits represent the ROM PAGE where the decoded tone is located.

Bit 1	Bit 0	DECODED ROM PAGE
0	0	A valid but unrecognized tone
0	1	Decoded tone in ROM Page 1
1	0	Decoded tone in ROM Page 2
1	1	Decoded tone in ROM Page 3

Table 6: DECODED ROM PAGE (Bits 1 and 0)

If the DECODE STATUS CHANGE (Bit 3) of the STATUS Register is '1' or the RAM FULL (Bit 4) of the STATUS Register changes from '0' to '1' then the \overline{IRQ} output will be pulled low.

Reading the STATUS register, clears the interrupt (\overline{IRQ} output pulled high) and also, clears Bit 3 of the STATUS Register, if set. A Clear RAM command clears Bit 4 of the STATUS Register, if set.

In Zero Power mode, Status Register Bits 7 to 0 are preset to "110x0000" respectively. RAM FULL (Bit 4) remains undisturbed.

6. Application Notes

6.1 General

The device should be reset first by the command GENERAL RESET \$01.

The decoder should then be set up according to the desired characteristics. This entails setting the DECODER BANDWIDTH and select the ROM PAGE in the CONTROL Register \$30, also selecting tones in the chosen ROM PAGE by TONE ADDRESS Register \$31 (programming the center frequencies of the desired tones).

Up to 8 tones can be programmed either from ROM PAGE 1 or ROM PAGE 2. The RAM memory location 1 is loaded first then incrementally loaded to location 8. Alternatively, a tone group can be selected from ROM PAGE 3.

The decoder is enabled by the CONTROL Register \$30.

During operation when the device is receiving, the tones are scanned in the sequence of their location; once a tone is detected, the remaining tones are not checked.

When the decoder detects a change in its present state an interrupt will be generated. The change that occurred can be read from Bit 3 of the STATUS Register \$3F if a tone is detected. NOTONE is indicated by Bit 2 of the same register. The ROM PAGE of that tone can be read from Bits 1 and 0 of the same register. The interrupt is cleared by reading the STATUS Register. The decoded tone address can be read from the DECODED TONE ADDRESS Register \$38

6.2 Tone Tables

The tables on the following pages list the commonly used paging tones and the corresponding ROM address for programming the TONE ADDRESS Register \$31.

D7	D6	D5	D4	D3	D2	D1	D0	Hex	ROM PAGE 1			ROM PAGE 2			
									System	Tone #	Freq.	System	Tone #	Chnl.	Freq.
0	0	0	0	0	0	0	0	00				Reach		0	Reserved
0	0	0	0	0	0	0	1	01	Mot.1	0	330.5	Single		1	Reserved
0	0	0	0	0	0	1	0	02		1	349	Tone		2	Reserved
0	0	0	0	0	0	1	1	03		2	368.5			3	Reserved
0	0	0	0	0	1	0	0	04		3	389			4	3446
0	0	0	0	0	1	0	1	05		4	410.8			5	3329
0	0	0	0	0	1	1	0	06		5	433.7			6	3215
0	0	0	0	0	1	1	1	07		6	457.9			7	3106
0	0	0	0	1	0	0	0	08		7	483.5			8	3000
0	0	0	0	1	0	0	1	09		8	510.5			9	2898
0	0	0	0	1	0	1	0	0A		9	539			10	2799
0	0	0	0	1	0	1	1	0B		Diag.	569.1	Reach	1	11	2704
0	0	0	0	1	1	0	0	0C	Mot. 2	0	569.1	Group A	2	12	2612
0	0	0	0	1	1	0	1	0D		1	600.9		3	13	2523
0	0	0	0	1	1	1	0	0E		2	634.5		4	14	2437
0	0	0	0	1	1	1	1	0F		3	669.9		5	15	2354
0	0	0	1	0	0	0	0	10		4	707.3		6	16	2274
0	0	0	1	0	0	0	1	11		5	746.8		7	17	2196
0	0	0	1	0	0	1	0	12		6	788.5		8	18	2121
0	0	0	1	0	0	1	1	13		7	832.5		9	19	2049
0	0	0	1	0	1	0	0	14		8	879		0	20	1980
0	0	0	1	0	1	0	1	15		9	928.1	Reach	1	21	1912
0	0	0	1	0	1	1	0	16		Diag.	979.9	Group B	2	22	1847
0	0	0	1	0	1	1	1	17	Mot. 3	0	1092.4		3	23	1784
0	0	0	1	1	0	0	0	18		1	288.5		4	24	1723
0	0	0	1	1	0	0	1	19		2	296.5		5	25	1664
0	0	0	1	1	0	1	0	1A		3	304.7		6	26	1608
0	0	0	1	1	0	1	1	1B		4	313		7	27	1553
0	0	0	1	1	1	0	0	1C		5	953.7		8	28	1500
0	0	0	1	1	1	0	1	1D		6	979.9		9	29	1449
0	0	0	1	1	1	1	0	1E		7	1006.9		0	30	1400
0	0	0	1	1	1	1	1	1F		8	1034.7	Reach	1	31	1352
0	0	1	0	0	0	0	0	20		9	1063.2	Group C	2	32	1306
0	0	1	0	0	0	0	1	21		Diag.	569.1		3	33	1261
0	0	1	0	0	0	1	0	22	Mot. 4	0	321.7		4	34	1219
0	0	1	0	0	0	1	1	23		1	339.6		5	35	1177
0	0	1	0	0	1	0	0	24		2	358.6		6	36	1137
0	0	1	0	0	1	0	1	25		3	378.6		7	37	1098
0	0	1	0	0	1	1	0	26		4	399.8		8	38	1061
0	0	1	0	0	1	1	1	27		5	422.1		9	39	1025
0	0	1	0	1	0	0	0	28		6	445.7		0	40	990
0	0	1	0	1	0	0	1	29		7	470.5	Reach	1	41	956
0	0	1	0	1	0	1	0	2A		8	496.8	Group D	2	42	923
0	0	1	0	1	0	1	1	2B		9	524.6		3	43	892
0	0	1	0	1	1	0	0	2C		Diag.	569.1		4	44	862

D7	D6	D5	D4	D3	D2	D1	D0	Hex	ROM PAGE 1			ROM PAGE 2			
									System	Tone #	Freq.	System	Tone #	Chnl.	Freq.
0	0	1	0	1	1	0	1	2D	Mot. 5	0	553.9	Reach	5	45	832
0	0	1	0	1	1	1	0	2E		1	584.8	Group D	6	46	804
0	0	1	0	1	1	1	1	2F		2	617.4	continue	7	47	776
0	0	1	1	0	0	0	0	30		3	651.9		8	48	750
0	0	1	1	0	0	0	1	31		4	688.3		9	49	725
0	0	1	1	0	0	1	0	32		5	726.8		0	50	700
0	0	1	1	0	0	1	1	33		6	767.4		1	51	676
0	0	1	1	0	1	0	0	34		7	810.2	Reach	2	52	653
0	0	1	1	0	1	0	1	35		8	855.5	Group E	3	53	631
0	0	1	1	0	1	1	0	36		9	903.2		4	54	609
0	0	1	1	0	1	1	1	37		Diag.	979.9		5	55	588
0	0	1	1	1	0	0	0	38	Mot. 6	0	1122.5		6	57	549
0	0	1	1	1	0	0	1	39		1	1153.4		7	58	530
0	0	1	1	1	0	1	0	3A		2	1185.2		8	59	512
0	0	1	1	1	0	1	1	3B		3	1217.8		9	60	495
0	0	1	1	1	1	0	0	3C		4	1251.4				-
0	0	1	1	1	1	0	1	3D		5	1285.8				-
0	0	1	1	1	1	1	0	3E		6	1321.2				-
0	0	1	1	1	1	1	1	3F		7	1357.6				-
0	1	0	0	0	0	0	0	40		8	1395				-
0	1	0	0	0	0	0	1	41		9	1433.4				-

D7	D6	D5	D4	D3	D2	D1	D0	Hex	ROM PAGE 1			ROM PAGE 2		
									System	Tone #	Freq.	System	Tone #	Freq.
0	1	0	0	0	0	1	0	42		Diag.	979.9	Plectron	0	282.2
0	1	0	0	0	0	1	1	43	Mot. 10	0	1472.9		1	294.7
0	1	0	0	0	1	0	0	44		1	1513.5		2	307.8
0	1	0	0	0	1	0	1	45		2	1555.2		3	321.4
0	1	0	0	0	1	1	0	46		3	1598		4	335.6
0	1	0	0	0	1	1	1	47		4	1642		5	350.5
0	1	0	0	1	0	0	0	48		5	1687.2		6	366
0	1	0	0	1	0	0	1	49		6	1733.7		7	382.3
0	1	0	0	1	0	1	0	4A		7	1781.5		8	399.2
0	1	0	0	1	0	1	1	4B		8	1830.5		9	416.9
0	1	0	0	1	1	0	0	4C		9	1881		10	435.3
0	1	0	0	1	1	0	1	4D	Mot. 11	0	1930.2		11	454.6
0	1	0	0	1	1	1	0	4E		1	1989		12	474.8
0	1	0	0	1	1	1	1	4F		2	2043.8		13	495.8
0	1	0	1	0	0	0	0	50		3	2094.5		14	517.8
0	1	0	1	0	0	0	1	51		4	2155.6		15	540.7
0	1	0	1	0	0	1	0	52		5	2212.2		16	564.7
0	1	0	1	0	0	1	1	53		6	2271.7		17	589.7
0	1	0	1	0	1	0	0	54		7	2334.6		18	615.8
0	1	0	1	0	1	0	1	55		8	2401		19	643

D7	D6	D5	D4	D3	D2	D1	D0	Hex	ROM PAGE 1			ROM PAGE 2		
									System	Tone #	Freq.	System	Tone #	Freq.
0	1	0	1	0	1	1	0	56		9	2468.2	Plectron	20	672
0	1	0	1	0	1	1	1	57	GE. A	0	682.5	continue	21	701
0	1	0	1	1	0	0	0	58		1	592.5		22	732
0	1	0	1	1	0	0	1	59		2	757.5		23	765
0	1	0	1	1	0	1	0	5A		3	802.5		24	799
0	1	0	1	1	0	1	1	5B		4	847.5		25	834
0	1	0	1	1	1	0	0	5C		5	892.5		26	871
0	1	0	1	1	1	0	1	5D		6	937.5		27	910
0	1	0	1	1	1	1	0	5E		7	547.5		28	950
0	1	0	1	1	1	1	1	5F		8	727.5		29	992
0	1	1	0	0	0	0	0	60		9	637.5		30	1036
0	1	1	0	0	0	0	1	61		Diag.	742.5		31	1082
0	1	1	0	0	0	1	0	62	GE. B	0	652.5		32	1130
0	1	1	0	0	0	1	1	63		1	607.5		33	1180
0	1	1	0	0	1	0	0	64		2	787.5		34	1232
0	1	1	0	0	1	0	1	65		3	832.5		35	1287
0	1	1	0	0	1	1	0	66		4	877.5		36	1344
0	1	1	0	0	1	1	1	67		5	922.5		37	1403
0	1	1	0	1	0	0	0	68		6	967.5		38	1465
0	1	1	0	1	0	0	1	69		7	517.5		39	1530
0	1	1	0	1	0	1	0	6A		8	562.5		40	1598
0	1	1	0	1	0	1	1	6B		9	697.5		41	1669

D7	D6	D5	D4	D3	D2	D1	D0	Hex	ROM PAGE 1			ROM PAGE 2		
									System	Tone #	Freq.	System	Tone #	Freq.
0	1	1	0	1	1	0	0	6C		Diag.	742.5	Plectron	42	1743
0	1	1	0	1	1	0	1	6D	GE. C	0	667.5	continue	43	1820
0	1	1	0	1	1	1	0	6E		1	712.5		44	1901
0	1	1	0	1	1	1	1	6F		2	772.5		45	1985
0	1	1	1	0	0	0	0	70		3	817.5		46	2073
0	1	1	1	0	0	0	1	71		4	862.5		47	2164
0	1	1	1	0	0	1	0	72		5	907.5		48	2260
0	1	1	1	0	0	1	1	73		6	952.5		49	2361
0	1	1	1	0	1	0	0	74		7	532.5		50	2465
0	1	1	1	0	1	0	1	75		8	577.5		51	2575
0	1	1	1	0	1	1	0	76		9	622.5		52	2688
0	1	1	1	0	1	1	1	77		Diag.	742.5		53	2807
0	1	1	1	1	0	0	0	78	Mot. A	0	358.9		54	2932
0	1	1	1	1	0	0	1	79		1	398.1		55	3062
0	1	1	1	1	0	1	0	7A		2	441.6		56	3197
0	1	1	1	1	0	1	1	7B		3	489.8		57	3339
0	1	1	1	1	1	0	0	7C		4	543.3		58	3487
0	1	1	1	1	1	0	1	7D		5	602.6		59	1957
0	1	1	1	1	1	1	0	7E		6	668.3			-
0	1	1	1	1	1	1	1	7F		7	741.3			-

D7	D6	D5	D4	D3	D2	D1	D0	Hex	ROM PAGE 1			ROM PAGE 3		
									System	Tone #	Freq.	System	Tone #	Freq.
1	0	0	0	0	0	0	0	80		8	822.2	EIA	0	600
1	0	0	0	0	0	0	1	81	Mot. A	9	912		1	741
1	0	0	0	0	0	1	0	82	continue	A	1011.6		2	882
1	0	0	0	0	0	1	1	83		B	1122.1		3	1023
1	0	0	0	0	1	0	0	84		Diag.	979.9		4	1164
1	0	0	0	0	1	0	1	85	Mot. B	0	371.5		5	1305
1	0	0	0	0	1	1	0	86		1	412.1		6	1446
1	0	0	0	0	1	1	1	87		2	457.1		7	1587
1	0	0	0	1	0	0	0	88		3	507		8	1728
1	0	0	0	1	0	0	1	89		4	562.3		9	1869
1	0	0	0	1	0	1	0	8A		5	623.7		A	2151
1	0	0	0	1	0	1	1	8B		6	691.8		B	2435
1	0	0	0	1	1	0	0	8C		7	767.4		X/C	2010
1	0	0	0	1	1	0	1	8D		8	851.1		D	2295
1	0	0	0	1	1	1	0	8E		9	944.1		R/E	459
1	0	0	0	1	1	1	1	8F		A	1047.1		F	-
1	0	0	1	0	0	0	0	90		B	1161.4	CCIR	0	1981
1	0	0	1	0	0	0	1	91		Diag.	979.9		1	1124
1	0	0	1	0	0	1	0	92	Mot. Z	0	346.7		2	1197
1	0	0	1	0	0	1	1	93		1	384.6		3	1275
1	0	0	1	0	1	0	0	94		2	426.6		4	1358
1	0	0	1	0	1	0	1	95		3	473.2		5	1446
1	0	0	1	0	1	1	0	96		4	524.8		6	1540
1	0	0	1	0	1	1	1	97		5	582.1		7	1640
1	0	0	1	1	0	0	0	98		6	645.7		8	1747
1	0	0	1	1	0	0	1	99		7	716.1		9	1860
1	0	0	1	1	0	1	0	9A		8	794.3		A	2400
1	0	0	1	1	0	1	1	9B		9	881		B	930
1	0	0	1	1	1	0	0	9C		A	977.2		X/C	2247
1	0	0	1	1	1	0	1	9D		B	1084		D	991
1	0	0	1	1	1	1	0	9E		Diag.	979.9		R/E	2110
1	0	0	1	1	1	1	1	9F	Zetron		1980		F	1055
1	0	1	0	0	0	0	0	A0	Grp. 1		2704	ZVE11	0	2400
1	0	1	0	0	0	0	1	A1			2612		1	1060
1	0	1	0	0	0	1	0	A2			2523		2	1160
1	0	1	0	0	0	1	1	A3			2437		3	1270
1	0	1	0	0	1	0	0	A4			2354		4	1400
1	0	1	0	0	1	0	1	A5			2274		5	1530
1	0	1	0	0	1	1	0	A6			2196		6	1670
1	0	1	0	0	1	1	1	A7			2121		7	1830
1	0	1	0	1	0	0	0	A8			2049		8	2000
1	0	1	0	1	0	0	1	A9	Grp. 2		1177		9	2200
1	0	1	0	1	0	1	0	AA			1608		A	2800
1	0	1	0	1	0	1	1	AB			1553		B	810
1	0	1	0	1	1	0	0	AC			1500		X/C	970

D7	D6	D5	D4	D3	D2	D1	D0	Hex	ROM PAGE 1			ROM PAGE 3		
									System	Tone #	Freq.	System	Tone #	Freq.
1	0	1	0	1	1	0	1	AD			1449	ZVEI1	D	885
1	0	1	0	1	1	1	0	AE	Zetron		1400	continue	R/E	2600
1	0	1	0	1	1	1	1	AF	Grp. 2		1352		F	680
1	0	1	1	0	0	0	0	B0	continue		1306	ZVEI2	0	2400
1	0	1	1	0	0	0	1	B1			1261		1	1060
1	0	1	1	0	0	1	0	B2			1219		2	1160
1	0	1	1	0	0	1	1	B3	Grp. 3		1400		3	1270
1	0	1	1	0	1	0	0	B4			1912		4	1400
1	0	1	1	0	1	0	1	B5			1847		5	1530
1	0	1	1	0	1	1	0	B6			1784		6	1670
1	0	1	1	0	1	1	1	B7			1723		7	1830
1	0	1	1	1	0	0	0	B8			1664		8	2000
1	0	1	1	1	0	0	1	B9			1608		9	2200
1	0	1	1	1	0	1	0	BA			1553		A	885
1	0	1	1	1	0	1	1	BB			1500		B	810
1	0	1	1	1	1	0	0	BC			1449		X/C	740
1	0	1	1	1	1	0	1	BD	Grp. 4		832		D	680
1	0	1	1	1	1	1	0	BE			1137		R/E	970
1	0	1	1	1	1	1	1	BF			1098		F	2600
1	1	0	0	0	0	0	0	C0			1061	ZVEI3/	0	2200
1	1	0	0	0	0	0	1	C1			1025	DZVEI	1	970
1	1	0	0	0	0	1	0	C2			990		2	1060
1	1	0	0	0	0	1	1	C3			956		3	1160
1	1	0	0	0	1	0	0	C4			923		4	1270
1	1	0	0	0	1	0	1	C5			892		5	1400
1	1	0	0	0	1	1	0	C6			862		6	1530
1	1	0	0	0	1	1	1	C7	Grp. 5		588		7	1670
1	1	0	0	1	0	0	0	C8			804		8	1830
1	1	0	0	1	0	0	1	C9			776		9	2000
1	1	0	0	1	0	1	0	CA			750		A	825
1	1	0	0	1	0	1	1	CB			725		B	740
1	1	0	0	1	1	0	0	CC			700		X/C	2600
1	1	0	0	1	1	0	1	CD			676		D	885
1	1	0	0	1	1	1	0	CE			653		R/E	2400
1	1	0	0	1	1	1	1	CF			631		F	680
1	1	0	1	0	0	0	0	D0			609	PZVEI	0	2400
1	1	0	1	0	0	0	1	D1			-		1	1060
1	1	0	1	0	0	1	0	D2			-		2	1160
1	1	0	1	0	0	1	1	D3			-		3	1270
1	1	0	1	0	1	0	0	D4			-		4	1400
1	1	0	1	0	1	0	1	D5			-		5	1530
1	1	0	1	0	1	1	0	D6			-		6	1670
1	1	0	1	0	1	1	1	D7			-		7	1830
1	1	0	1	1	0	0	0	D8			-		8	2000

D7	D6	D5	D4	D3	D2	D1	D0	Hex	ROM PAGE 1			ROM PAGE 3		
									System	Tone #	Freq.	System	Tone #	Freq.
1	1	0	1	1	0	0	1	D9			-	PZVEI	9	2200
1	1	0	1	1	0	1	0	DA			-	continue	A	970
1	1	0	1	1	0	1	1	DB			-		B	810
1	1	0	1	1	1	0	0	DC			-		X/C	2800
1	1	0	1	1	1	0	1	DD			-		D	885
1	1	0	1	1	1	1	0	DE			-		R/E	2600
1	1	0	1	1	1	1	1	DF			-		F	680
1	1	1	0	0	0	0	0	E0			-	EEA	0	1981
1	1	1	0	0	0	0	1	E1			-		1	1124
1	1	1	0	0	0	1	0	E2			-		2	1197
1	1	1	0	0	0	1	1	E3			-		3	1275
1	1	1	0	0	1	0	0	E4			-		4	1358
1	1	1	0	0	1	0	1	E5			-		5	1446
1	1	1	0	0	1	1	0	E6			-		6	1540
1	1	1	0	0	1	1	1	E7			-		7	1640
1	1	1	0	1	0	0	0	E8			-		8	1747
1	1	1	0	1	0	0	1	E9			-		9	1860
1	1	1	0	1	0	1	0	EA			-		A	1055
1	1	1	0	1	0	1	1	EB			-		B	930
1	1	1	0	1	1	0	0	EC			-		X/C	2247
1	1	1	0	1	1	0	1	ED			-		D	991
1	1	1	0	1	1	1	0	EE			-		R/E	2110
1	1	1	0	1	1	1	1	EF			-		F	2400
1	1	1	1	0	0	0	0	F0			-			-
1	1	1	1	0	0	0	1	F1			-			-
1	1	1	1	0	0	1	0	F2			-			-
1	1	1	1	0	0	1	1	F3			-			-
1	1	1	1	0	1	0	0	F4			-			-
1	1	1	1	0	1	0	1	F5			-			-
1	1	1	1	0	1	1	0	F6			-			-
1	1	1	1	0	1	1	1	F7			-			-
1	1	1	1	1	0	0	0	F8			-			-
1	1	1	1	1	0	0	1	F9			-			-
1	1	1	1	1	0	1	0	FA			-			-
1	1	1	1	1	0	1	1	FB			-			-
1	1	1	1	1	1	0	0	FC			-			-
1	1	1	1	1	1	0	1	FD			-			-
1	1	1	1	1	1	1	0	FE			-			-
1	1	1	1	1	1	1	1	FF			-			-

7. Performance Specification

7.1 Electrical Performance

7.1.1 Absolute Maximum Ratings

Exceeding these maximum ratings can result in damage to the device.

	Min.	Max.	Units
Supply ($V_{DD} - V_{SS}$)	-0.3	7.0	V
Voltage on any pin to V_{SS}	-0.3	$V_{DD} + 0.3$	V
Current into or out of V_{DD} and V_{SS} pins	-30	+30	mA
Current into or out of any other pin	-20	+20	mA
E4 Package	Min.	Max.	Units
Total Allowable Power Dissipation at $T_{AMB} = 25^{\circ}\text{C}$		300	mW
Derating above 25°C		5	mW/ $^{\circ}\text{C}$ above 25°C
Storage Temperature	-55	+125	$^{\circ}\text{C}$
Operating Temperature	-40	+85	$^{\circ}\text{C}$
P3 Package			
Total Allowable Power Dissipation at $T_{AMB} = 25^{\circ}\text{C}$		800	mW
Derating above 25°C		13	mW/ $^{\circ}\text{C}$ above 25°C
Storage Temperature	-55	+125	$^{\circ}\text{C}$
Operating Temperature	-40	+85	$^{\circ}\text{C}$

7.1.2 Operating Limits

Correct operation of the device outside these limits is not implied.

	Notes	Min.	Max.	Units
Supply ($V_{DD} - V_{SS}$)		2.7	5.5	V
Operating Temperature		-40	+85	$^{\circ}\text{C}$
Xtal Frequency		3.579187	3.579903	MHz

7.1.3 Operating Characteristics

For the following conditions unless otherwise specified:

Xtal Frequency = 3.579545MHz. $V_{DD} = 2.7V$ to $5.5V$, $T_{AMB} = -40^{\circ}C$ to $+85^{\circ}C$.

Noise Bandwidth = 5kHz Band Limited Gaussian, 0dB reference = $775mV_{RMS}$

	Notes	Min.	Typ.	Max.	Units
DC Parameters					
At $V_{DD} = 2.7V$					
I_{DD} (Zero Power)	1	-	1.0	2.0	μA
I_{DD} (Operating)	1	-	0.5	1.0	mA
At $V_{DD} = 5.0V$					
I_{DD} (Zero Power)	1	-	1.0	2.0	μA
I_{DD} (Operating)	1	-	1.0	2.0	mA
C-BUS Interface					
Input Logic "1"		70%	-	-	V_{DD}
Input Logic "0"		-	-	30%	V_{DD}
Input Leakage Current (Logic "1" or "0")		-1.0	-	1.0	μA
Input Capacitance		-	-	7.5	pF
Output Logic "1" ($I_{OH} = 360\mu A$)		90%	-	-	V_{DD}
Output Logic "0" ($I_{OL} = 360\mu A$)		-	-	10%	V_{DD}
\overline{IRQ} output "Off" State Leakage Current ($V_{OUT} = V_{DD}$)		-	-	1.0	μA
AC Parameters					
Decoder					
Sensitivity	2	-	-65.0	-	dB
Tone Measurement Resolution		-	0.2	-	%
Tone Measurement Accuracy		-	0.5	-	%
Response Time 2-Tone Mode	3	-	30.0	46.0	ms
De-Response Time 2-Tone Mode	3	-	76.0	82.0	ms
Response Time 5/6-Tone and HSC Mode	3	-	25.0	34.0	ms
De-Response Time 5/6-Tone and HSC Mode	3	-	43.0	62.0	ms
Frequency Range		280	-	3500	Hz
Signal/Noise			2.0		dB
Input Amplifier					
Open Loop Gain (input = 1mV at 100Hz)		-	70.0	-	dB
Unity Gain Bandwidth		-	5.0	-	MHz
Input Impedance (at 100Hz)		10.0	-	-	$M\Omega$
Output Impedance (Open Loop)		-	6.0	-	k Ω
Xtal/Clock Input					
Pulse Width ('High' or 'Low')	4	40.0	-	-	ns
Input Impedance (at 100Hz)		10.0	-	-	$M\Omega$
Gain (input = $1mV_{RMS}$ at 100Hz)		20.0	-	-	dB

Notes:

1. Not including any current drawn from the device pins by external circuitry.
2. At $V_{DD} = 5.0V$ only. Signal levels are proportional to V_{DD} , driven with a source impedance of $<1000\Omega$.
3. 2-tone mode covers tones from ROM Page 1 and 2; 5/6-tone and HSC mode covers tones from ROM Page 3. Deresponse times are for 95% probability.
4. Timing for an external input to the XTAL/CLOCK pin.

7.1.4 Timing

C-BUS Timings (See Figure 3 and Note 5)		Notes	Min.	Typ.	Max.	Unit
t_{CSE}	\overline{CS} -Enable to Clock-High time		100	-	-	ns
t_{CSH}	Last Clock-High to \overline{CS} -High time		100	-	-	ns
t_{LOZ}	Clock-Low to Reply Output enable time		0.0	-	-	ns
t_{HIZ}	\overline{CS} -High to Reply Output 3-state time		-	-	1.0	μ s
t_{CSOFF}	\overline{CS} -High Time between transactions		1.0	-	-	μ s
t_{NXT}	Inter-Byte Time		500	-	-	ns
t_{CK}	Clock-Cycle time		500	-	-	ns
t_{CH}	Serial Clock-High time		200	-	-	ns
t_{CL}	Serial Clock-Low time		200	-	-	ns
t_{CDS}	Command Data Set-Up time		75	-	-	ns
t_{CDH}	Command Data Hold time		25	-	-	ns
t_{RDS}	Reply Data Set-Up time		75	-	-	ns
t_{RDH}	Reply Data Hold time		0	-	-	ns

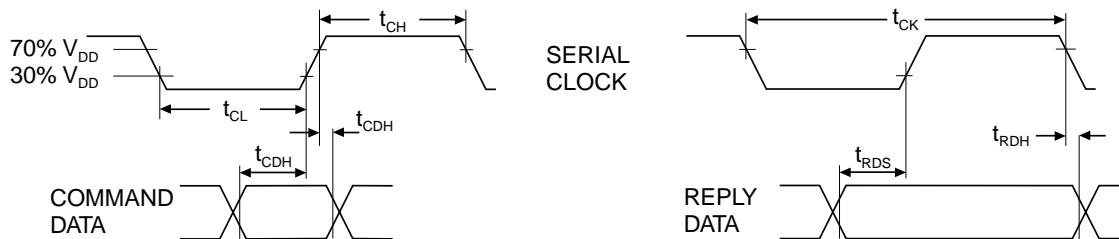
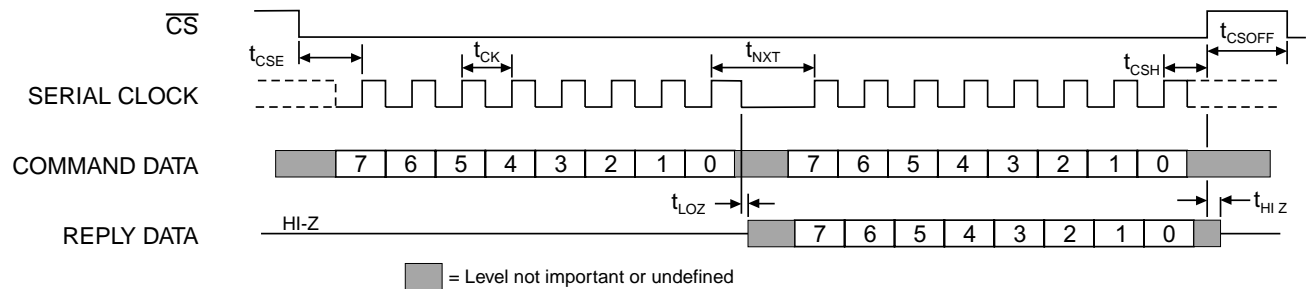
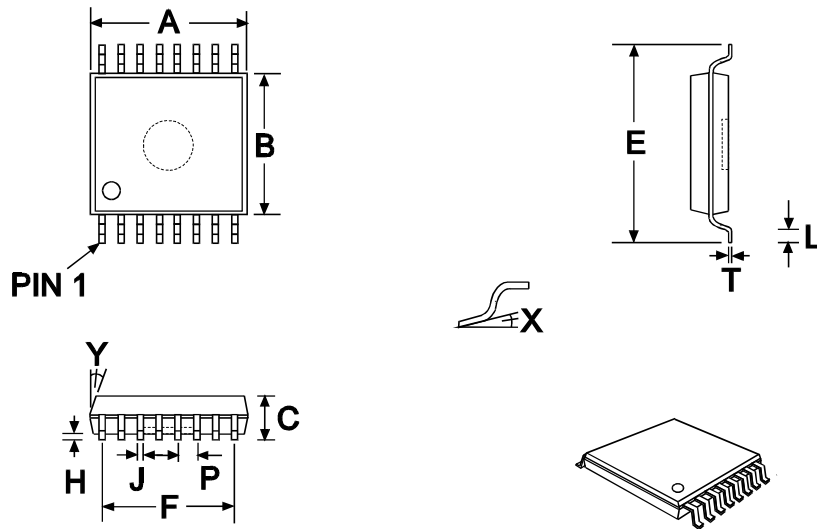

Figure 3: C-BUS Timing

Notes:

1. Depending on the command, 1 or 2 bytes of COMMAND DATA are transmitted to the peripheral MSB (Bit 7) first, LSB (Bit 0) last. REPLY DATA is read from the peripheral MSB (Bit 7) first, LSB (Bit 0) last.
2. Data is clocked into and out of the peripheral on the rising SERIAL CLOCK edge.
3. Loaded commands are acted upon at the end of each command.
4. To allow for differing μ Controller serial interface formats C-BUS compatible ICs are able to work with either polarity SERIAL CLOCK pulses.
5. These timings are for the latest version of the C-BUS as embodied in the CMX813, and allow faster transfers than the original C-BUS timings given in MX-COM's Publication Doc. # 20480060.001.

7.2 Packaging



DIM.	MIN.	TYP.	MAX.
* A	0.193 (4.90)		0.201 (5.10)
* B	0.169 (4.30)		0.177 (4.50)
C	-----		0.047 (1.20)
E	0.248 (6.30)		0.256 (6.50)
F		0.179 (4.55)	
H	0.002 (0.05)		0.006 (0.15)
J	0.007 (0.17)		0.012 (0.30)
L	0.020 (0.50)		0.030 (0.75)
P		0.026 (0.65)	
T	0.003 (0.08)		0.008 (0.20)
X	0°		7°
Y		12°	

NOTE :

* A & B are reference data and do not include mold deflash or protrusions.

All dimensions in inches (mm.)
Angles are in degrees

Figure 4: 16-pin TSSOP (E4) Mechanical Outline: Order as part no. CMX813E4

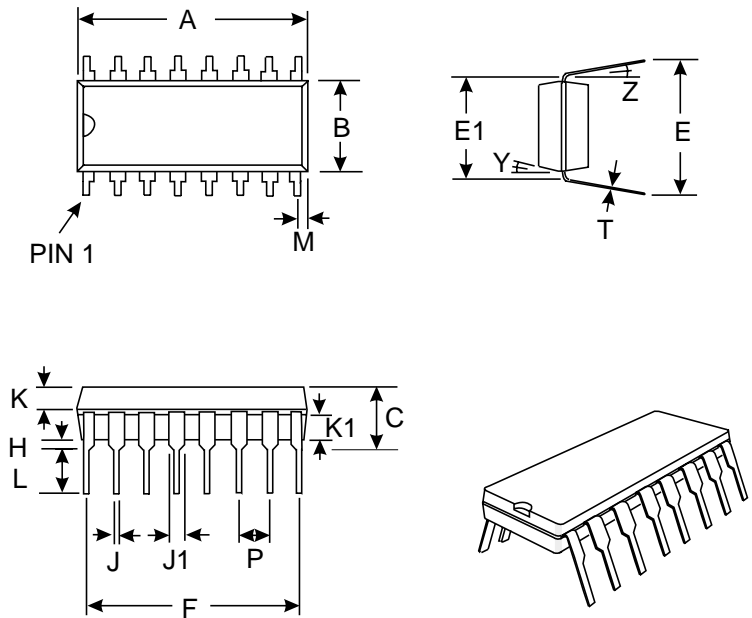

DIM.	MIN.	TYP.	MAX.
* A	0.740 (18.80)		0.810 (20.57)
* B	0.240 (6.10)		0.262 (6.65)
C	0.135 (3.43)		0.200 (5.08)
E	0.300 (7.62)		0.390 (9.91)
E1	0.290 (7.37)		0.325 (8.26)
F		0.70 (17.78)	
H	0.015 (0.38)		0.040 (1.02)
J	0.015 (0.38)		0.023 (0.58)
J1	0.040 (1.02)		0.065 (1.65)
K	0.056 (1.42)		0.064 (1.63)
K1	0.056 (1.42)		0.064 (1.63)
L	0.121 (3.07)		0.150 (3.81)
M		0.028 (0.71)	
P		0.100 (2.54)	
T	0.008 (0.20)		0.015 (0.38)
Y		7°	
Z		5°	

NOTE :

* A & B are reference datum's and do not include mold deflash or protrusions.

All dimensions in inches (mm.)
Angles are in degrees

Figure 5: 16-pin PDIP (P3) Mechanical Outline: Order as part no. CMX813P3