

% " F9DF9G9BHG5 7F #7 5@8A 9BGC B"
&" A 5L D-B FC H5HC B -B 6C 8MHC 69&S"
' " DI G<C I H: C F7 9HC 69%V " Q(") BOA -B"
(" BC H9 89@H98
) : C F @ 7? B: 7 @DG "+" V " O " " * BOA -B F9H9BHC B
** A 95G F9 5H69B8"

Bc " C: DC GHC BG
!\$&HFI !&

C DHC B

!@ : @ 7? B: 7 @D
" " fl G9 @ ! \$) ! HA : C F H: FC I ; < < C @ G H M @ Z G99 : ± " %&
" " fl G9 @ ! \$) ! HA : C F ! GA ' G H M @ Z G99 : ± " " Z G < H ' & &
" " B C H 5 J 5 - 6 @ : C F ! F 5 ' G H M @ Z
! H F : H 5 D 9 / F 9 9 @ f i C F ! GA C D H C B C B @ M
! ? : D C @ M A - B 9 : - A D 5 8 f l G 9 ? !) \$ \$! \$ \$ Z G 9 9 : ± " (Z G < H ' & &
" " B C H 5 J 5 - 6 @ K + k ! H: C D H C B
! L L : D - B B c " H C ' 6 9 C A # H 8 F D C 6 F # 9 8 C D H C B L

D 6 HB: GD97 ± 7 5 HC B

! G ' G 9 @ 7 H J 9 ; C @ 8 f l G 9 H % G % ! L L ! G & &
! @ @ : < H G 9 @ 7 H J 9 f l G 9 H % G % ! L L ! @ & &
! : : 6 5 G < : C @ 8 G 9 @ 7 H J 9
" " f l G 9 H % G % ! L L ! : ! & &

6C 8M < 9 ± < H

! H k : H k F C I ; < < C @ f G 9 9 : ± " % Z G < H ' % &
! F 5 : F ± < H 5 B ; @ f G 9 9 : ± " % Z G < H ' & &
! G A : G I F : 5 7 9 A C I B H f G 9 9 : ± " " Z G < H & &

F C K GD97 ± 7 5 HC B

! 8 : 8 C I 6 @ f l G 9 9 H A ! L L ! 8 ! @ 7 L

: ± "%
9HA A !%Q)!\$&L!8!H!@ 'G<C K B

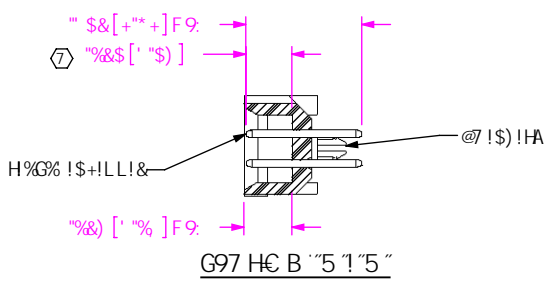
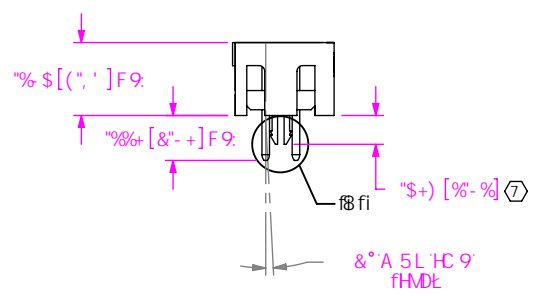
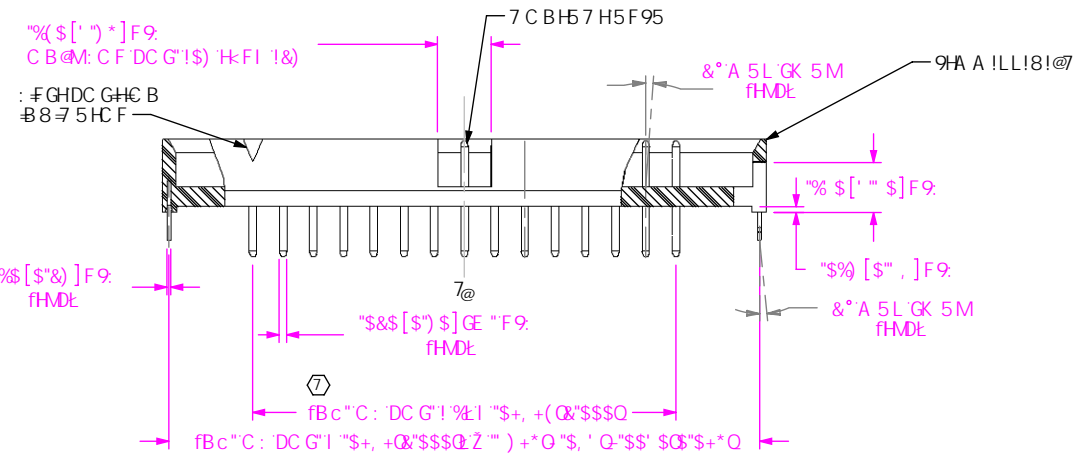
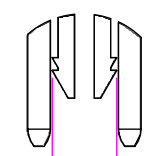
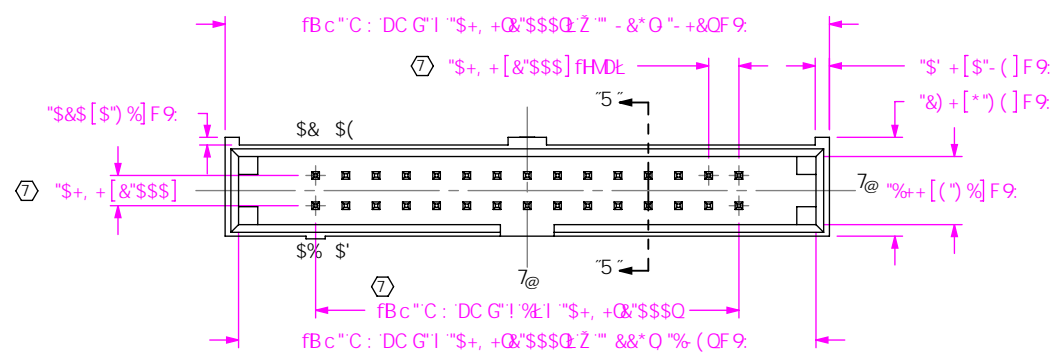

I B @GG C H 9FK 69 GD97 ± 98Z
8 A 9BGC BG5F9 -B 7 < 9G"
HC @F5B7 9G 5F9.
897 A 5 @G : 5 B ; @G
" L L : ± "\$%Q " Q " " %"
" L L L : ± "\$%Q " Q " " %"
" L L L L : ± "\$%Q " Q " " %"
H: 68C 71A 98H7C B16 8G B: CFA 5HC B
7 C B: 89B H5 65B8 DFC DF 96F M C
G5A H7 Z 4 B 7 5 B 8 G 5 @ B C H 6 9 F 9 0 F C 8 I 7 9 8
C F H 5 B G 9 F 9 8 H C C H 9 F B C 7 I A 9 B H G C F
8 4 7 @ C 9 8 H C C H 9 F G C F I 0 9 8 : C F 5 B M
D I F D C 0 9 C H 9 F H 5 B H 5 H K < 7 < H K 5 G
C 6 H 5 8 9 8 K # C I H H 9 9 L D F 9 6 9 8 K F # H 8
7 C B 0 9 8 H C : G 5 A H 7 Z 4 B 7 "



) & \$ D 5 F ? 9 5 G H 6 @ 8 2 B 9 K 5 6 5 B M Z B (+) \$
D < C B 9 ; % & - ((1 * +) : : : : 5 L : % & - (, !) \$ (+
Y I A U J : j z : 4 G 5 A H 7 " W c a : : : : " V c X Y .)) & &

A 5 H F 4 @ 8 C " B C H 7 5 @ 9 8 F 5 K B : G 9 9 H 7 5 @ 9 . & %
- B G @ H C F . N M @ < H B : F) & ' \$ B < 2 7 C @ F . ' 6 @ 5 7 ?
H F A - B 5 @ D < C G D < C F ' 6 F C B N 9

89G7 F DHC B.
8 A ' G < F C I 8 9 8 H F A - B 5 @ G F - D
8 K : " B C "

9HA A !%LL!\$&!8!LL!LL
6M HB 9K HC B %&#%+&#\$%+ G<99H% C : '

F9J €€ B '5

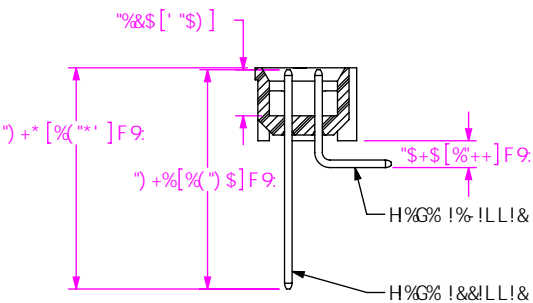
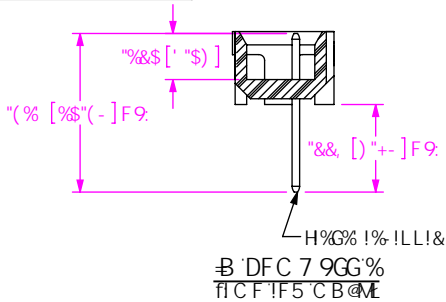

B'DFC 7 9GG% FICF!F5'CB@M

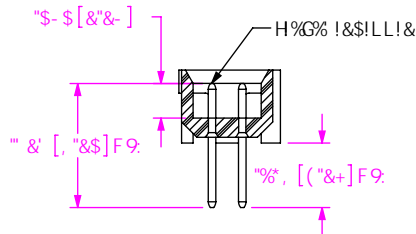

B'DFC 7 9GG% FICF!GA'CB@M

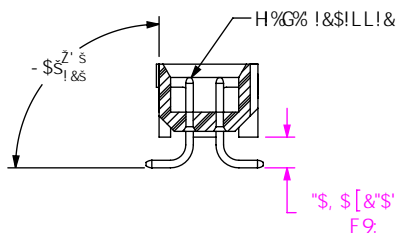

B'DFC 7 9GG% FICF!GA'CB@M

9HA A 1%00! \$&L!8!F5'G<C K B
FB #: 9F9BH5GG<C K B Z C H 9FK €9 G5A 9'5 G: ≠ "%&

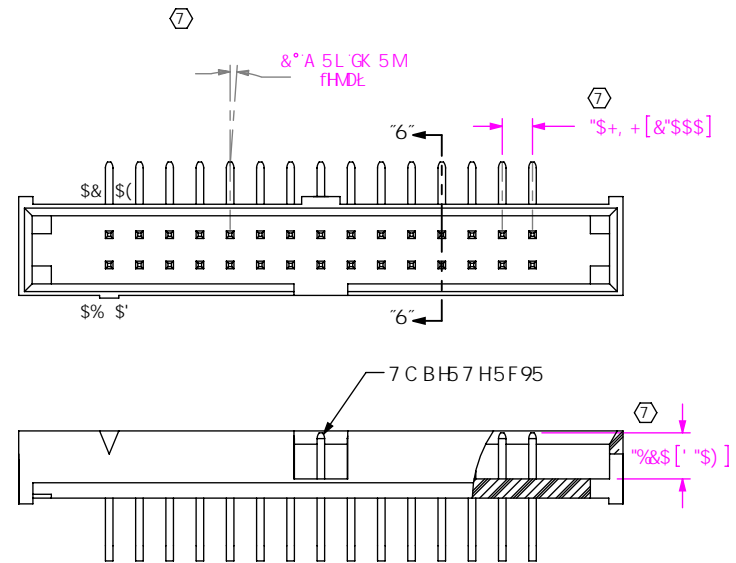
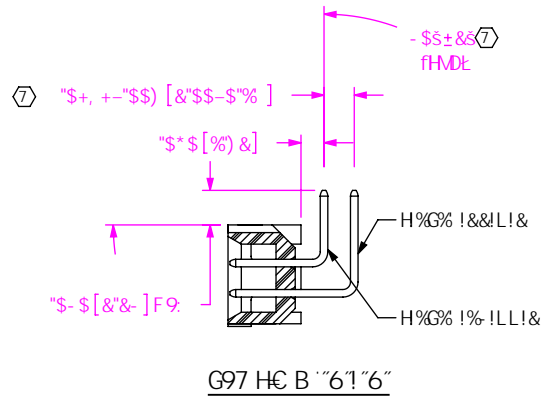

9HA A 1%00! \$&L!8!GA!@ 'G<C K B
FB #: 9F9BH5GG<C K B Z C H 9FK €9 G5A 9'5 G: ≠ "%&

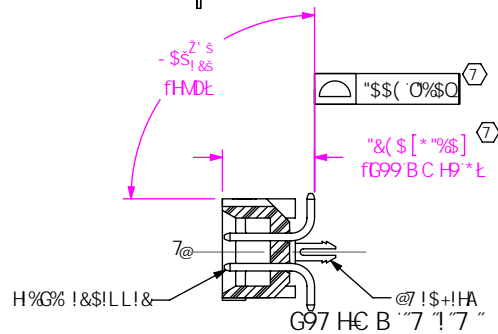
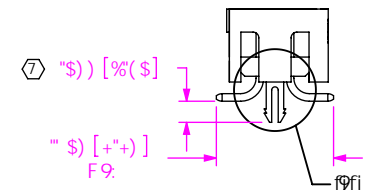
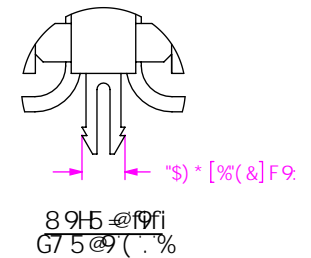
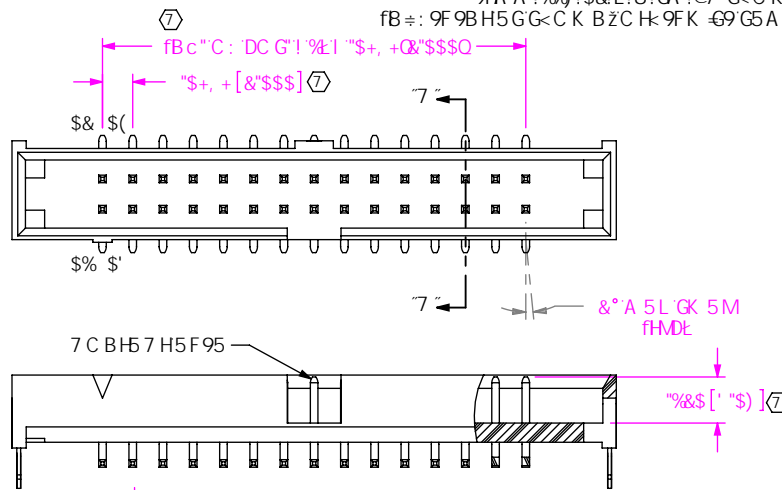

WPYbhr/fd/fj/Ui 1P8K : PA €7 PA ?H P9HA A 1%LL!S&L!8!LL!LL!IA ?HG88FK

DFC DF 9H5 FMBC H9
H: €8C 71A 98H7 C BH5 BG B: CFA 5HC B
7 C B: €98H5€5B8 DFC DF 9H5 F H M C
GSA H97 2 87 "5B8 G-5M8C H69 F90C 81 7 98
CF HF5B G 9F98 HC CH: 9F 8C 71A 98H6 C F
8 47 @C 098 HC CH: 9F G C F I 098 : C F 58 M
DI FDC 09 CH: 9F H: 5B H: 5HK < 7 < H K 5 G
C 6H5 B 98 K H: C I H: 9 9 L DF 9098 K F H 68
7 C B G 98 HC : GSA H97 2 87 "

8C 'BCH G7 5 €9 8F5K B:

G: 99H G7 5 €9 & %

santec

) & \$ D5 F? 95 GH6 @ 8 Z B 9 K ' 5 @ 5 B M B (+) \$
D < C B 9 ; % & L - ((! * +) : ; & : % & L - (,) \$ (+
Y I A U J ; } € 4 GSA H97 "Wc a W€XY.) ' &&

8 9G7 F €HC B:

& A ' G < F C I 8 98 ' H 9 F A B 5 @ G F € D

8K : "BC"

9HA A 1%LL! \$&L!8!LL!LL!

6M HB 9K HC B % & # % + # & \$ \$ + G < 99H & C : '

: ÷ ""
 9HA A !%0 ! \$& L I 8 ! GA ! ? G< C K B
 fB ÷: 9F 9B H 5 G< C K B ' C H: 9FK €9' G5 A 9' 5 G: ÷ "%&L

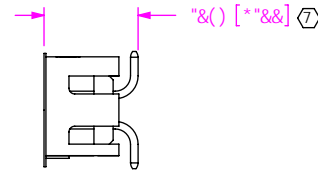
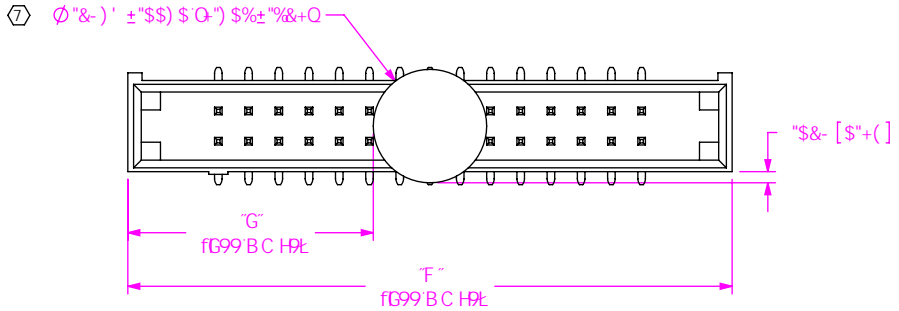

BC H9 'F "1 1 G98 'A 95 G I F 98 '8-A 9B G € B 'f F 9: L
 "G" 1 d f F "1 " & -) ' G -) \$ Q # & q ± "\$&\$€B") %Q

D57?5; B;
 5 @ D5 F HG 5 F 9 @ C 5 8 98 K F R: DC G H C B %
 H C K 5 F 8 5 F F C K ' 9 L 7 9 D H I F 5 C D H C B

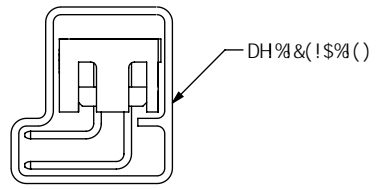
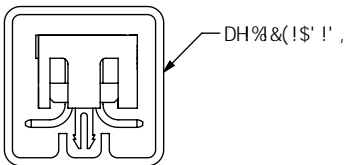
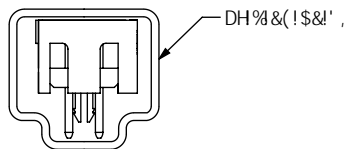

BC H9 '5 @ DC G H C B G 5 F 9 H C ' 69 H 698 "

TABLE 1		
OPTIONS	PACKAGING TUBE	PLUG
-TH, -TH-LC	PT-1-24-02-38	TP-03
-SM, -SM-LC	PT-1-24-03-38	TP-03
-RA	PT-1-24-01-45	TP-07

D F C D F 9 5 F M B C H 9
 H: € B C 7 1 A 9 8 H 7 C B B B G € C F A 5 H C B
 7 C B: € 9 8 H 5 9 5 8 B D F C D F 9 4 5 F H M C
 G S A H 9 7 2 8 7 " 5 8 8 G 5 8 8 B C H 6 9 F 9 0 F C 8 1 7 9 8
 C F I F 5 B G 9 F 9 8 H C C H: 9 F 8 C 7 1 A 9 8 H C F
 8 4 7 @ C 9 8 H C C H: 9 F G C F I 9 8: C F 5 B M
 D I F D C 9 C H: 9 F H: 5 B H: 5 H K < 7 < # H K 5 G
 C 6 1 5 B 9 8 K H: C I H H: 9 9 L D F 9 0 9 8 K F # H 8
 7 C B G 9 8 H C: G S A H 9 7 2 8 7 "

8 C ' B C H G 7 5 @ 9 8 F 5 K B:

G: 99 H 7 5 @ 9 & %

santec

) & \$ D 5 F ? 9 5 G H 6 @ 8 2 B 9 K ' 5 @ 5 B M B ' (+) \$
 D < C B 9 ; % & - ((! * + ' & ; & ; & - (,) \$ (+
 Y I A U J :) b z 4 G S A H 9 7 " W c a " W E X Y .)) ' & &

8 9 6 7 F € H C B:
 & A A ' G < F C I 8 9 8 ' H 9 F A B 5 @ G F €

8 K: " " B C "

9 H A A ! % & L ! \$ & ! 8 ! L L L L L

6 M H B 9 K H C B % & # % + # & \$ \$ + G < 9 9 H " " C: '