

THIS DRAWING IS UNPUBLISHED. RELEASED FOR PUBLICATION
 © COPYRIGHT BY TYCO ELECTRONICS CORPORATION. ALL RIGHTS RESERVED.

LOC	DIST	REVISIONS					
FT	0	P	LTR	DESCRIPTION	DATE	DWN	APVD
			T	REVISED PER ECO-06-3414	2/21/06	SS	SH

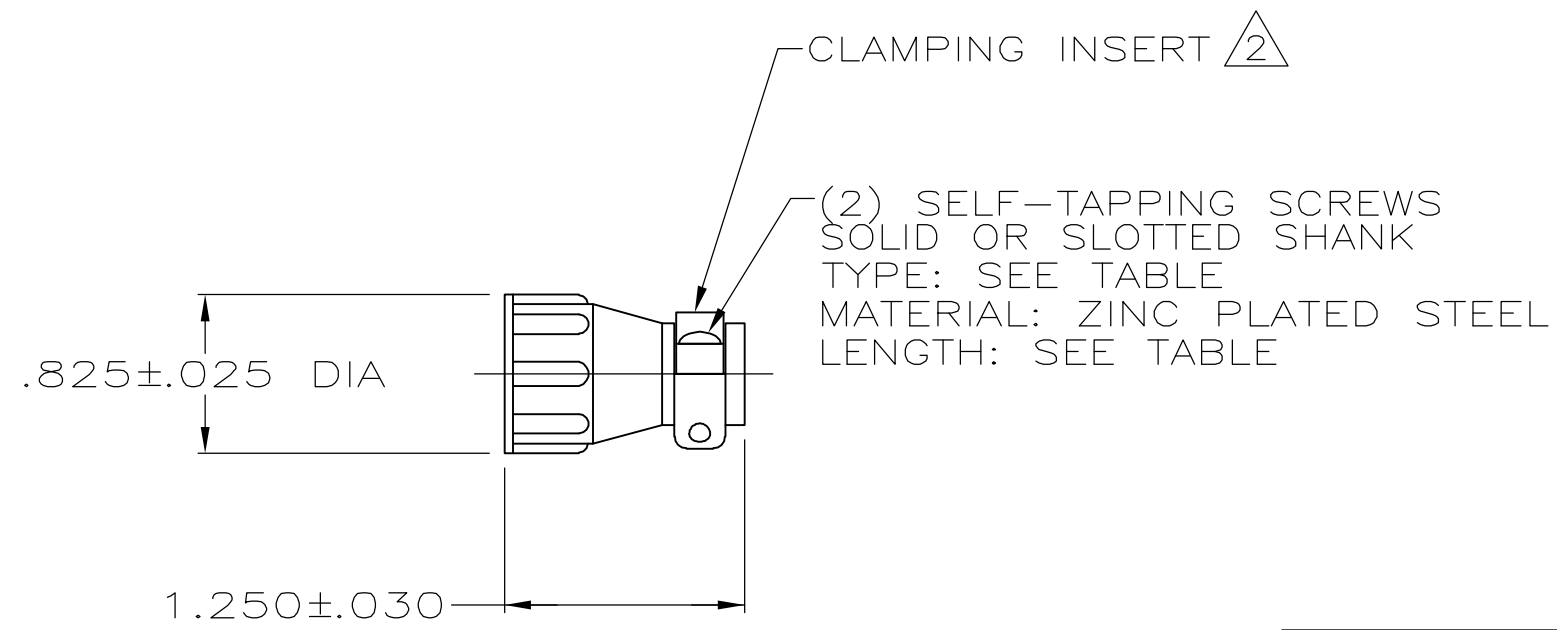

- PARTS PACKAGED UNASSEMBLED.
- CABLE CLAMPING AREA ADJUSTABLE FROM .004 TO .055 SQ IN BY REVERSING CLAMPING INSERTS.
- .329 MAXIMUM CABLE OUTSIDE DIAMETER.
- BULK PACKAGED KITS TO BE ORDERED IN MULTIPLES OF 400 ONLY.
- OBSOLETE PART NUMBER.
- ZINC PLATED STEEL, HEXAVALENT CHROMATE.
- STAINLESS STEEL (NON MAGNATIC).
- CABLE CLAMP WITH NON-MAGNETIC STAINLESS STEEL SCREWS.
- ZINC PLATED STEEL, NON-HEXAVALENT CHROMATE.

INDIVIDUAL	9	.375	#5-20	1-206062-6
4 BULK	9	.375	#5-20	1-206062-5
INDIVIDUAL	9	.500	#5-20	1-206062-4
INDIVIDUAL	9	.625	#5-20	1-206062-3
8 INDIVIDUAL	7	.500	#5-20	1-206062-2
INDIVIDUAL	6	.625	#5-20	1-206062-1
SMALL PACK	6	.375	#5-20	1-206062-0
AMP BRAZIL USE ONLY	6	12mm	3mm-20	5 206062-9
AMP BRAZIL USE ONLY	6	10mm	3mm-20	5 206062-8
4 BULK	6	.500	#5-20	206062-4
INDIVIDUAL	6	.500	#5-20	206062-3
4 BULK	6	.375	#5-20	206062-2
INDIVIDUAL	6	.375	#5-20	206062-1
PACKAGING	SCREW FINISH	SCREW LENGTH	SCREW TYPE	PART NUMBER

AMP BRAZIL USE ONLY
 AMP BRAZIL USE ONLY

THIS DRAWING IS A CONTROLLED DOCUMENT.		DWN A GRAFF 4/29/91	Tyco Electronics Corporation Harrisburg, PA 17105-3608	
DIMENSIONS: INCHES		CHK W.G.LENKER 7-22-92	NAME	
		APVD	CABLE CLAMP KIT, STANDARD, SHELL SIZE 11, CPC	
TOLERANCES UNLESS OTHERWISE SPECIFIED:		PRODUCT SPEC	RESTRICTED TO	
0 PLC ± - 1 PLC ± - 2 PLC ± - 3 PLC ± - 4 PLC ± - ANGLES ± -		APPLICATION SPEC	SIZE	CAGE CODE
MATERIAL: THERMOPLASTIC, FINISH: -		WEIGHT: -	A3	00779
		CUSTOMER DRAWING	DRAWING NO	RESTRICTED TO
			C=206062	
		SCALE: NTS	SHEET: 1 OF 1	REV: T