

COLOR VIDEO CONTROLLER

PRODUCT OVERVIEW

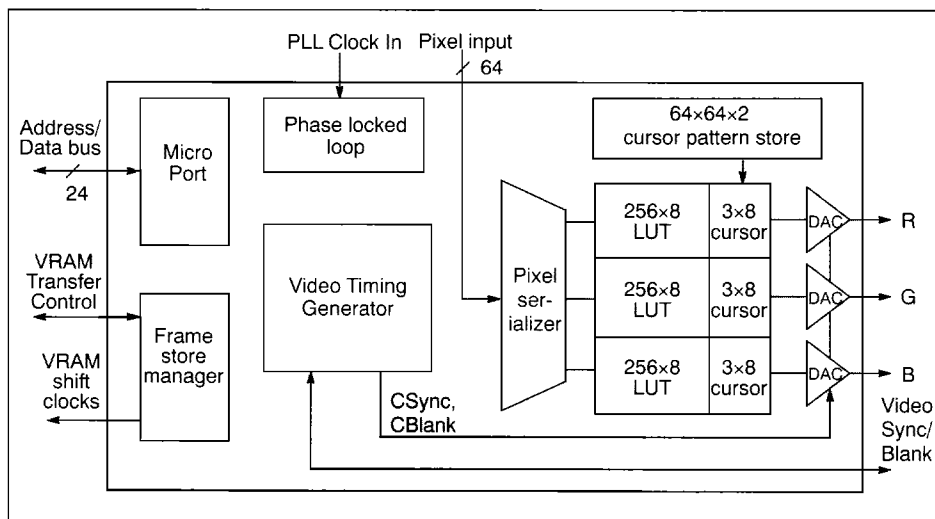

FEATURES

- Video rates up to 110MHz
- 1, 2, 4 and 8 bit pseudo color pixels
- 15 or 16 bit true color with gamma correction
- 24 bit full color with gamma correction
- Software configurable video timing generator
- Comprehensive video RAM framestore manager
- On-chip phase-locked loop pixel clock generator
- 64x64 pixel x3 color hardware cursor
- Triple 8-bit DACs
- Triple 256x8 anti-sparkle lookup RAM

BENEFITS

- Reduced component count
- Reduced system power consumption
- Enhanced system flexibility
- Easy upgradeability
- Broadcast standards compliance
- All digital signals below RFI regulated frequency
- Software compatible with IMS G332

APPLICATIONS

- High resolution graphics and imaging
- Broadcast/CC television systems
- Multimedia
- Graphical user interfaces
- X-terminals
- Low cost workstations

DESCRIPTION

The IMS G364 is a high performance CMOS device which integrates all the subsystem functions required to control high resolution color graphics displays.

This device has now been superseded by the IMS G365, which offers higher performance and greater ease of design.

The IMS G365 is recommended for all new designs. Full engineering data on the IMS G364 is still available from your local sales office if required.

TABLE OF CONTENTS

14.1 Introduction 237
14.2 Package specifications 240
14.3 Ordering information 242

14.1 Introduction

The IMS G364 provides all the necessary functions to control real-time operation of a raster scan video display, using dual-ported video RAMs.

The device consists of a 64 bit variable format multiplexed pixel interface, a programmable video timing generator (VTG), a 256 location color lookup table (LUT) with variable addressing modes, triple 8 bit video Digital-to-Analogue Convertors (video DACs), a 64x64x2 bit cursor store and 3 location cursor LUT, a programmable cursor positioning/insertion controller, a video memory control system and phase-locked loop clock generator.

A brief description of each functional block follows, for more detailed information please refer to the relevant section in the full datasheet.

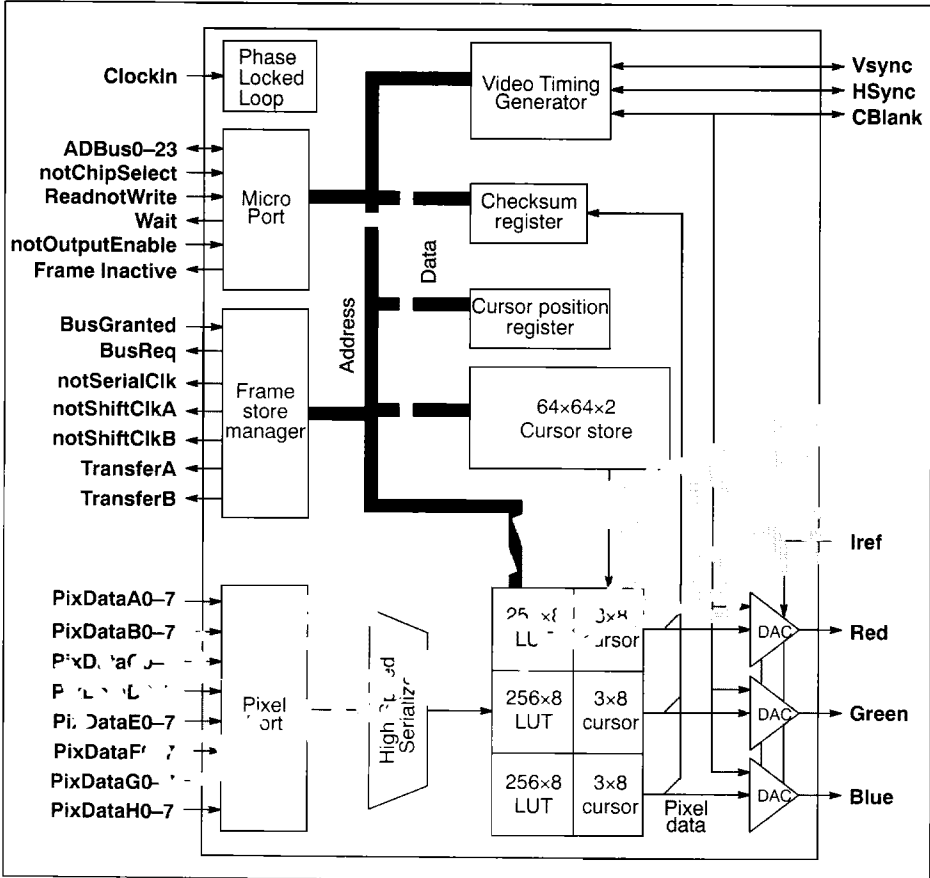

Figure 14.1 IMS G364 Block Diagram

14.1.1 Clocks

An on-chip phase-locked loop clock generator allows the IMS G364 to be driven from a low speed clock in the 5MHz to 10MHz range, which is internally multiplied by a user-specified factor to achieve video data rates. The controller can be clocked by a full rate system clock if desired, although at a reduced frequency compared to that achievable with the PLL.

14.1.2 Micro Port

The entire IMS G364 register space is read/write accessible via the micro port. This is a 24 bit wide synchronous interface, with multiplexed address and data, for single-cycle access to all registers. A wait pin is provided to allow synchronisation between the IMS G364 clock regime and that of the processor or interface bus. This interface is also used to provide the VRAM shift register transfer address.

14.1.3 Video timing generator

The video timing generator is a programmable finite state machine which uses a set of screen description parameters to produce the monitor sync and DAC blanking signals as well as the video RAM shift clock signals. It can be configured to be the system master or, as a slave, to lock onto an external signal which is already synchronous or has been previously genlocked. This may be from another INMOS CVC, giving the potential for multiple, synchronous video systems. The timing generator runs at one quarter of the video dot rate and the screen description parameters therefore have a resolution of four pixel periods.

14.1.4 Framestore manager

All the requirements of supporting a video RAM framestore are met by the IMS G364. The Framestore manager uses two framestore description parameters to maintain a constant supply of pixels to the pixel interface. It supports synchronous reload by supplying the refresh address and the transfer strobes, synchronised to the VRAM SC signals, so that a packed pixel framestore can be implemented regardless of the variations in screen format and framestore architecture. The refresh address generator supports all current VRAM standards together with the NTSC and PAL/SECAM screen formats.

14.1.5 Pixel Port

High pixel rates are achieved by multiplexing the video RAM serial outputs into a 64-bit wide pixel port. The IMS G364 supplies the shift clock signal, automatically adjusting its frequency, along with the multiplex ratio of the port, according to the bits per pixel mode selected. The minimum acceleration ratio is 4:1, achieved in 24 bits per pixel (bpp) mode by the use of an interleaved memory system, for which all the necessary signals are supplied.

14.1.6 Hardware Cursor

The hardware cursor is a complete system. The cursor store and lookup table are memory mapped, its position being modified by a single register access which can occur at any time, becoming valid at the next frame scan. The cursor position is stored in 2's complement relative to the top left pixel on the screen and is independent of monitor specifications.

14.1.7 Anti-sparkle Color Palette

The serialised pixels are used as addresses into a triple 256x8 pipelined RAM. In pseudo color modes one address is applied to all three RAMs giving a maximum of 256 simultaneous colors out of a possible 16.7 million. In true color each RAM is independently addressed for gamma correction of up to 16.7 million simultaneous colors. The palette has an anti-sparkle mechanism which reduces the visible effect of palette updates during display.

14.1.8 Video DACs

The three 8-bit DACs drive RS-170 level signals directly into a 37.5Ω load. They are blanked with programmable setup, internally by the VTG, externally by the CBlank pin or by a combination of the two. Composite Sync may be added to all three DACs.

14.1.9 System Operation

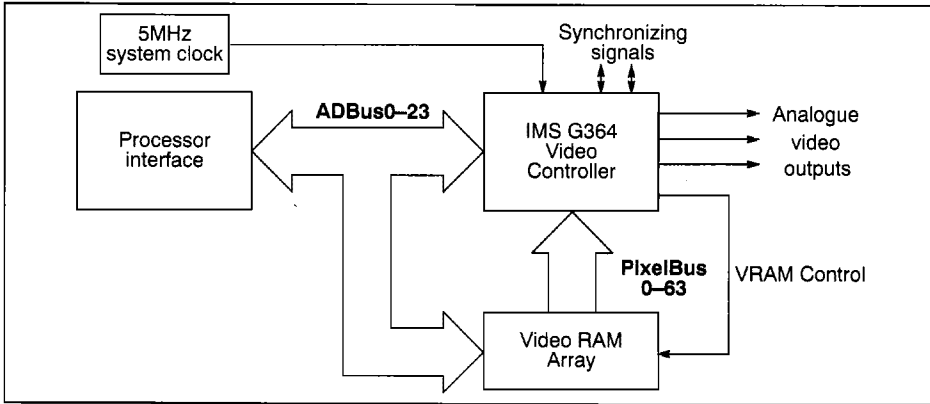

Figure 14.2 IMS G364 operating in a simple graphics system

Figure 14.2 shows how the IMS G364 would fit into a typical single-bitmap display system. The clock is typically sourced from a 5MHz crystal, with the video data being streamed to the screen at the full video rate of up to 110MHz. The video RAM array is directly accessed by the processor, with screen management automatically being performed by the IMS G364. All external digital signals and clocks are running at one quarter of the video rate, alleviating problems of high speed system design.

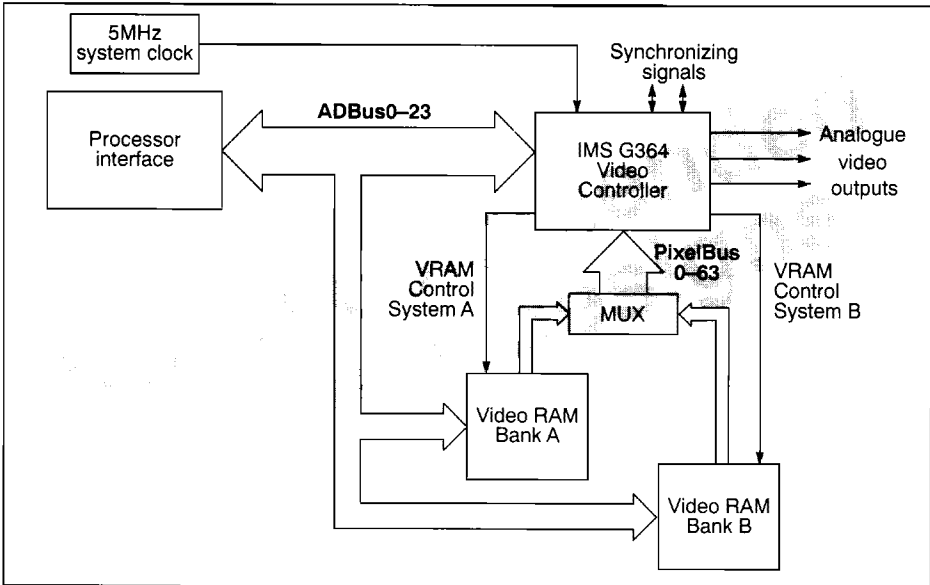

Figure 14.3 IMS G364 operating with an interleaved memory system

Figure 14.3 shows the organisation of an interleaved framestore. The IMS G364 accepts alternate loads from each bank in turn through an external multiplexor (or if the video rate is low enough - about 85MHz - the VRAM serial output enables can be used instead of external hardware). The IMS G364 supplies all the controls required to implement this architecture.

14.2 Package specifications

14.2.1 132 pin grid array package

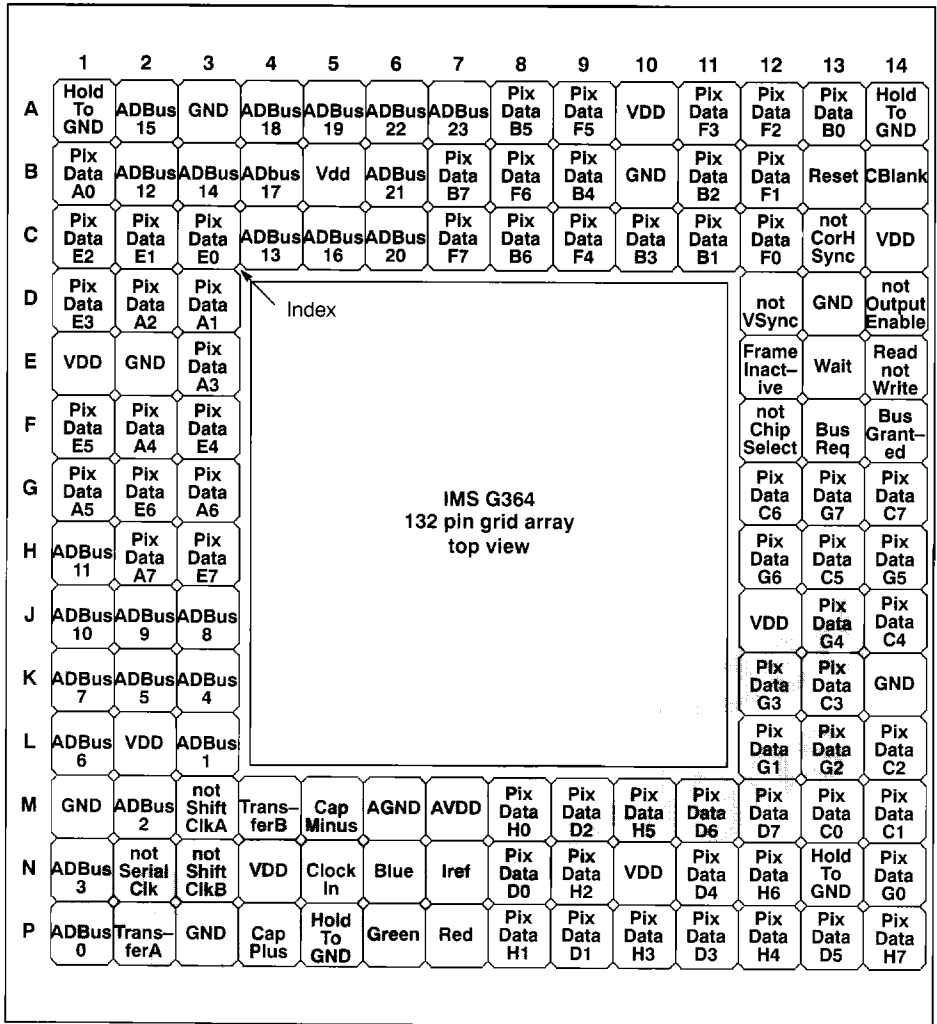

Figure 14.4 IMS G364 pin configuration

DIM	CONTROL DIMENSIONS INCH			ALTERNATIVE DIMENSIONS mm		
	MIN	NOM	MAX	MIN	NOM	MAX
A	0.130	0.142	0.155	3.302	3.607	3.937
A1	-	0.050REF	-	-	1.270REF	-
A2	0.080	0.092	0.105	2.032	2.337	2.667
B	0.016	0.018	0.020	0.406	0.457	0.508
B1	-	0.050REF	-	-	1.270REF	-
D	1.385	1.450	1.465	35.179	36.830	37.211
D1	-	1.300REF	-	-	33.020REF	-
e	-	0.100BSC	-	-	2.540BSC	-
E	1.385	1.450	1.465	35.179	36.830	37.211
E1	-	1.300REF	-	-	33.020REF	-
L	0.120	0.130	0.140	3.048	3.302	3.556

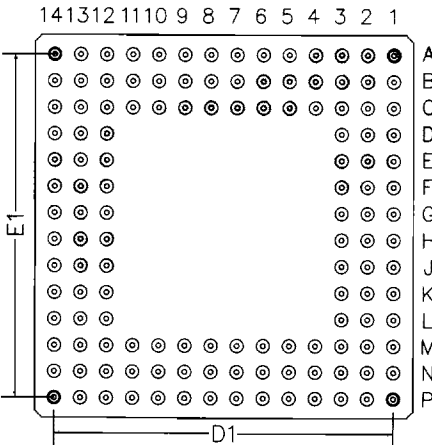
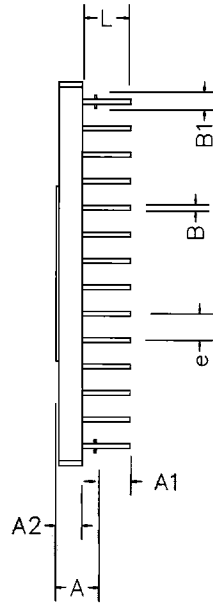
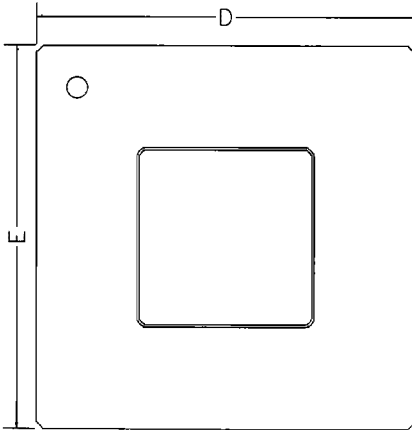

Figure 14.5 132 pin grid array package dimensions

14.3 Ordering information

Device	Clock rate	Package	Part number
IMS G364	85 MHz	132 pin grid array	IMS G364G-85S
IMS G364	100 MHz	132 pin grid array	IMS G364G-10S
IMS G364	110 MHz	132 pin grid array	IMS G364G-11S