



Features

- Compatible with SAE J1979
- 2.7 to 6V operating range
- MIL LED output
- Fixed or variable PIDs
- Simulates 3 ECUs
- functional addressing
- MODE 1,2,3,4,7,9
- IFR 0 and IFR 1 possible

Description

OE91C1210 can simulate ECM (engine ECU address 0x10) , TCM (transmission control ECU address 0x18) and ABS ECU address 0x28 simultaneously.

It is compatible with OE90C1200. EOBD modes (1,2,3,4,7,9) are implemented. Each ECU has own PID table and variable PID can be changed via potentiometers. The ECM can generate more than 3 DTCs.

The OE91C1210 communicate at 41.6 kbaud.

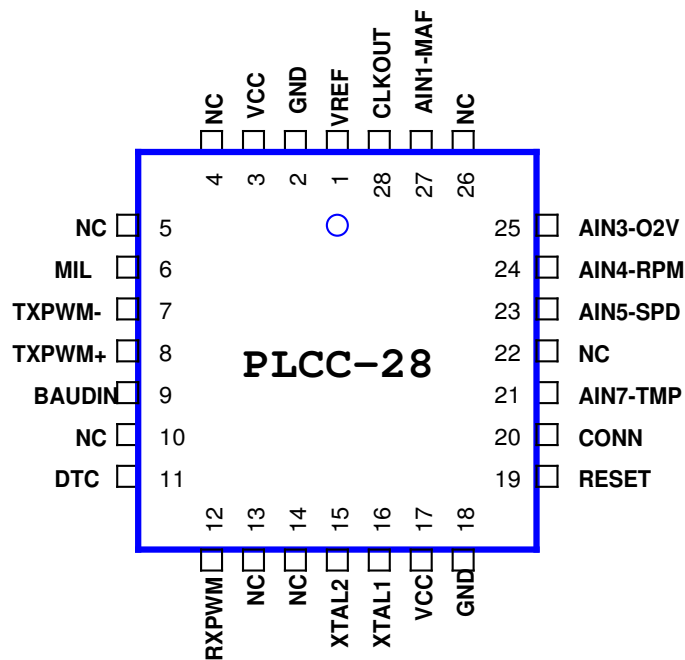

**J1850 PWM
MULTIPLE ECU
simulator according
to SAE J1979**

OE91C1210





Pin description

Pin	Pin Name	Type	Description
1	VREF	I	2.5 V extern ref input for ADC
2	GND		Ground
3	VCC		Supply voltage
4	NC		
5	NC		
6	MIL	O	MIL LED max 5 mA for low current LED
7	TXPWM-	O	PWM(-) output
8	TXPWM+	O	PWM(+) output
9	BAUDIN		16 x RS232 Baudrate input clock
10	NC	I	NC
11	DTC	I	DTC generation
12	RXPWM	I	PWM input
13	NC		NC
14	NC		NC
15	XTAL2	I	16 Mhz crystal input
16	XTAL1	I	16 MHz crystal input
17	VCC		Supply voltage
18	GND	I	Ground
19	RESET	I/O	A high level on this pin during 2 machine cycles while the oscillator is running resets the device.
20	LED2	O	LED output to indicate ECU connected to tester
21	AN7	I	Analog canal 7 INPUT
22	NC		NC
23	AN5	I	Analog canal 5 input
24	AN4	I	Analog canal 4 input
25	AN3	I	Analog canal 3 input
26	NC	I	NC
27	AN1		Analog canal 1 input
28	CLKOUT	O	Clock output for RS232 baud rate in

**ECM (engine control modul 0x10)****Mode 1**

PID	Description	fixed Raw Value	Var. Raw Value
03	Fuel system status	00	-
04	Engine Load	50	
05	ECT		0..255
06	STFT 1	60	
07	LTFT 1	70	
0C	RPM		0..65535
0D	VSS		0..255
0F	IAT	45	
10	MAF		0...65535
13	Location of O2 sensors	Bank 1 sensor 1	-
14	O2 volt		0..255
1C	OBD Type	EOBD	-
1F	Time since motor start		increments after simulator power on.
21	Distance traveled		increments while MIL LED is active
2F	FLI	100	
33	BARO	102	
42	Control voltage	12000	
46	AAT	75	

Mode 2

when the DTC input is low , P0100 cause a freeze frame storage as follow :

PID	Description	Stored Value
05	Engine coolant temp.	40
0C	Engine RPM	1234
0D	Vehicle speed sensor	67

Mode 3

If DTC button input is low , the MIL LED will be active and the DTCs for , mode 2 , mode 3 and 7 are generated.

when requesting this MODE the 6 DTCs come from ECM P0100 , P0200 , P0300 , U0100 , B0200 , C0300



Mode 4

delete the DTCs and freeze frame storage datas. MIL LED turns off.

Mode 7

While MIL LED is active , when requesting this MODE the 3 DTCs come from ECM
P0107 , P0207 , P0307

Mode 9

Infotypes 1 and 2 are implemented . when requesting VIN Number the response
is

VIN#=OZENELEKTRONIK123



TCM (transmission control modul 0x18)

Mode 1

PID	Description	fixed Raw Value	Var. Raw Value
05	Engine coolant temp.		0..255
0C	Engine RPM		0..65535
0D	Speed		0..255
1C	OBD Type	EOBD	-

Mode 2

Not implemented

Mode 3

While MIL LED is active , when requesting this MODE the 1 DTCs come from TCM P0101

Mode 4

delete the DTC . MIL LED turns off.

Mode 7

While MIL LED is active , when requesting this MODE the 2 DTCs come from TCM . P0102 , U1600

Mode 9

Not implemented



ABS (ABS modul 0x28)

Mode 1

PID	Description	fixed Raw Value	Var. Raw Value
0D	Speed		0..255
1C	OBD Type	EOBD	-

Mode 2

Not implemented

Mode 3

No DTC

Mode 4

No DTC

Mode 7

While MIL LED is active , 1 DTCs come from ABS (B2245)

Mode 9

Not implemented



Application notes

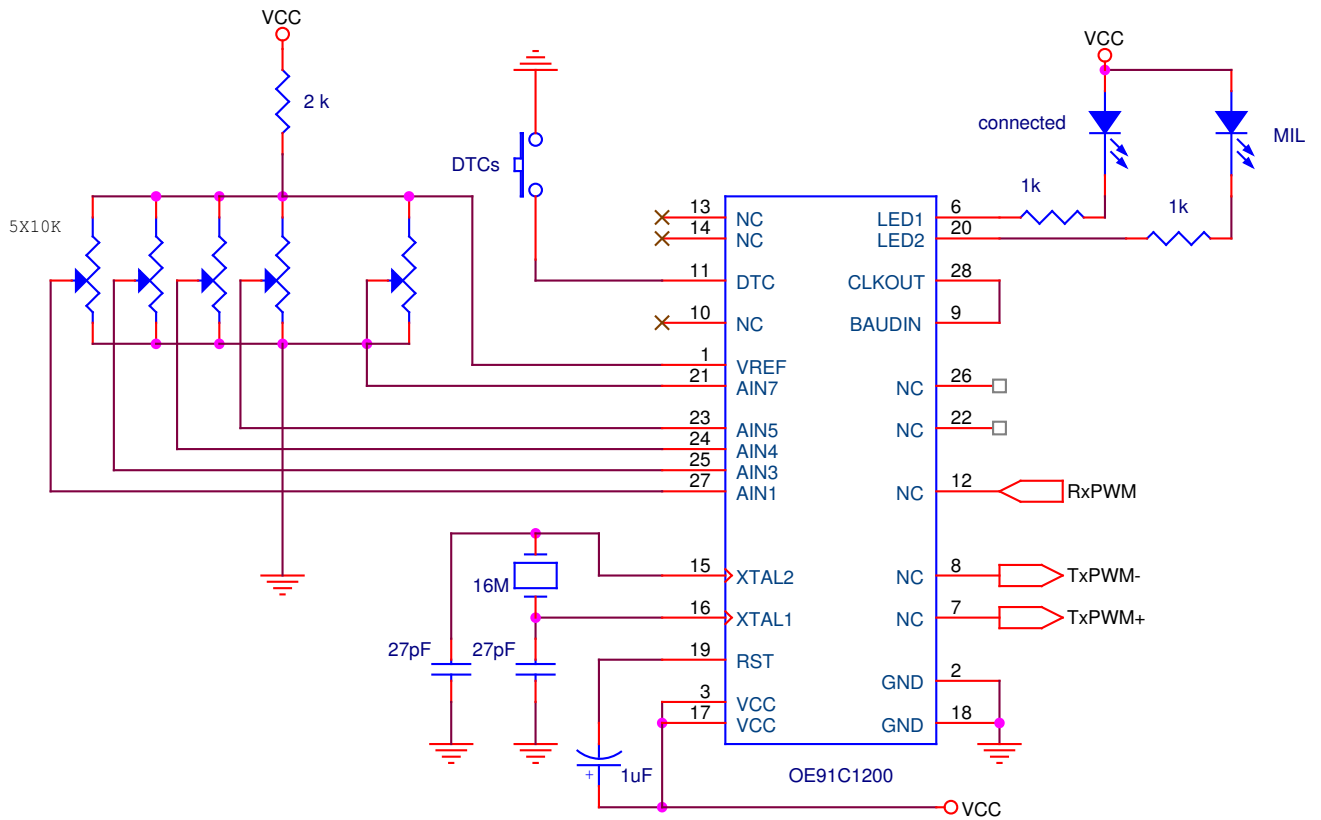

- the both LEDs are low current $I_f < 5 \text{ mA}$.
- Don't change the value of crystal.

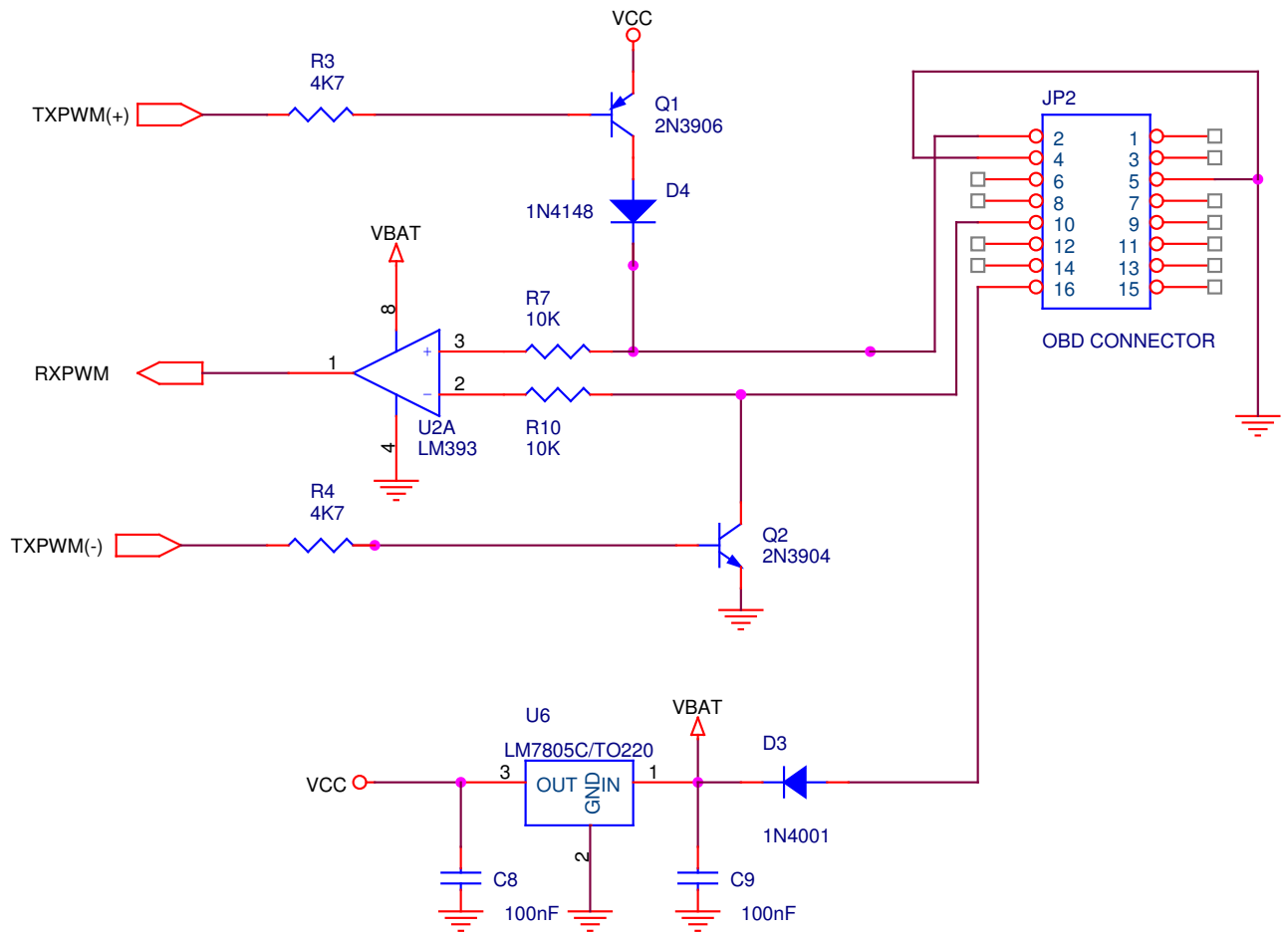

- use a 12 VDC / 500 mA Adapter to power the simulator and the tester.
- A femal OBD connector must be used.