



LM145/LM345 Negative Three Amp Regulator

General Description

The LM145 is a three-terminal negative regulator with a fixed output voltage of $-5V$ or $-5.2V$, and up to 3A load current capability. This device needs only one external component—a compensation capacitor at the output, making it easy to apply. Worst case guarantees on output voltage deviation due to any combination of line, load or temperature variation assure satisfactory system operation.

Exceptional effort has been made to make the LM145 immune to overload conditions. The regulator has current limiting which is independent of temperature, combined with thermal overload protection. Internal current limiting protects against momentary faults while thermal shutdown prevents junction temperatures from exceeding safe limits during prolonged overloads.

Although primarily intended for fixed output voltage applications, the LM145 may be programmed for higher output voltages with a simple resistive divider. The low quiescent drain

current of the device allows this technique to be used with good regulation.

The LM145 comes in a hermetic TO-3 package rated at 25W. A reduced temperature range part LM345 is also available.

Features

- Output voltage accurate to better than $\pm 2\%$
- Current limit constant with temperature
- Internal thermal shutdown protection
- Operates with input-output voltage differential of 2.8V at full rated load over full temperature range
- Regulation guaranteed with 25W power dissipation
- 3A output current guaranteed
- Only one external component needed
- P+ Product Enhancement tested

Schematic Diagram

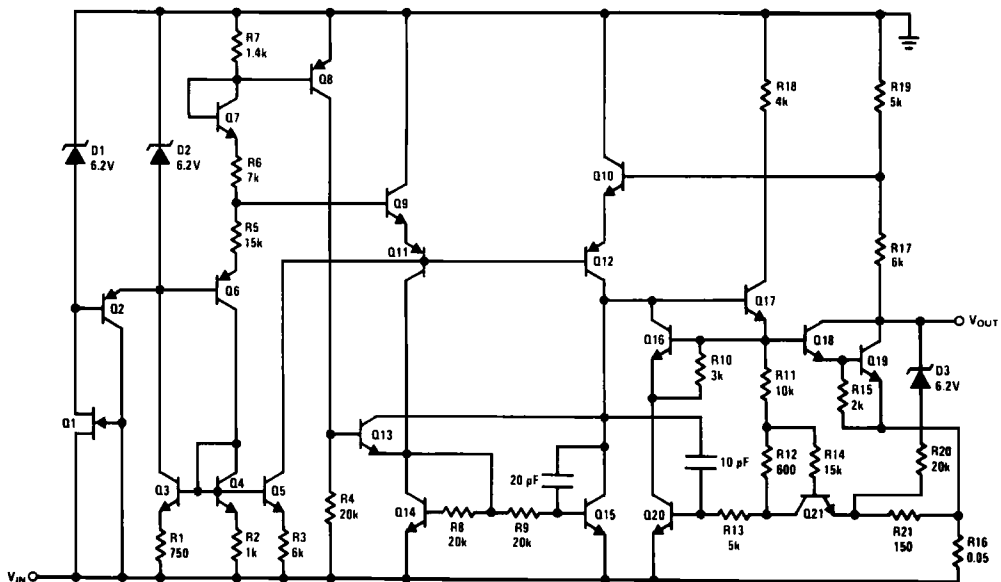

TL/H/7785-1

Absolute Maximum Ratings

If Military/Aerospace specified devices are required, please contact the National Semiconductor Sales Office/Distributors for availability and specifications. (Note 3)

Input Voltage	20V
Input-Output Differential	20V

Power Dissipation	Internally Limited
Operating Junction Temperature Range	
LM145	-55°C to +150°C
LM345	0°C to +125°C
Storage Temperature Range	-65°C to +150°C
Lead Temperature (Soldering, 10 sec.)	300°C

Electrical Characteristics (-5V & -5.2V) (Note 1)

Parameter	Conditions	Limits						Units
		LM145			LM345			
		Min	Typ	Max	Min	Typ	Max	
Output Voltage 5.0V 5.2V	$T_j = 25^\circ\text{C}$, $I_{OUT} = 5\text{ mA}$, $V_{IN} = -7.5$	-5.1 -5.3	-5.0 -5.2	-4.9 -5.1	-5.2 -5.4	-5.0 -5.2	-4.8 -5.0	V V
Line Regulation (Note 2)	$T_j = 25^\circ\text{C}$ $-20\text{V} \leq V_{IN} \leq -7.5\text{V}$		5	15		5	25	mV
Load Regulation (Note 2)	$T_j = 25^\circ\text{C}$, $V_{IN} = -7.5\text{V}$ $5\text{ mA} \leq I_{OUT} \leq 3\text{ A}$		30	75		30	100	mV
Output Voltage 5.0V 5.2V	$-20\text{V} \leq V_{IN} \leq -7.8\text{V}$ $5\text{ mA} \leq I_{OUT} \leq 3\text{ A}$ $P \leq 25\text{W}$ $T_{MIN} \leq T_j \leq T_{MAX}$	-5.20 -5.40		-4.80 -5.00	-5.25 -5.45		-4.75 -4.95	V V
Quiescent Current	$-20\text{V} \leq V_{IN} \leq -7.5\text{V}$ $5\text{ mA} \leq I_{OUT} \leq 3\text{ A}$		1.0	3.0		1.0	3.0	mA
Short Circuit Current	$V_{IN} = -7.5\text{V}$, $T_j = +25^\circ\text{C}$ $V_{IN} = -20\text{V}$, $T_j = +25^\circ\text{C}$		4 2	5.5 3.5		4 2	5.5 3.5	A A
Output Noise Voltage	$T_A = 25^\circ\text{C}$, $C_L = 4.7\ \mu\text{F}$ $10\text{ Hz} \leq f \leq 100\text{ kHz}$		150			150		μV
Long Term Stability			5	50		5	50	mV
Thermal Resistance Junction to Case			2			2		$^\circ\text{C}/\text{W}$

Note 1: Unless otherwise specified, these specifications apply: $-55^\circ\text{C} \leq T_j \leq +150^\circ\text{C}$ for the LM145 and $0^\circ\text{C} \leq T_j \leq +125^\circ\text{C}$ for the LM345. $V_{IN} = 7.5\text{V}$ and $I_{OUT} = 5\text{ mA}$. Although power dissipation is internally limited, electrical specifications apply only for power levels up to 25W. For calculations of junction temperature rise due to power dissipation, use a thermal resistance of 35°C/W for the TO-3 with no heat sink. With a heat sink, use 2°C/W for junction to case thermal resistance.

Note 2: Regulation is measured at constant junction temperature. Changes in output voltage due to heating effects must be taken into account separately. To ensure constant junction temperature, pulse testing with a low duty cycle is used.

Note 3: Refer to RETS145K-5.2V for LM145K-5.2V or RETS145K-5V for LM145K-5.0 military specifications.

Connection Diagram

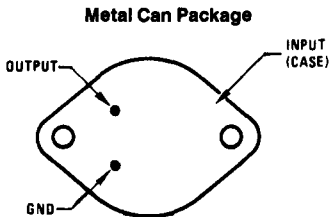

Bottom View
Order Number LM145K-5.0,
LM345K-5.0, LM145K-5.2,
or LM345K-5.2
See NS Package Number K02A

TL/H/7785-2

Typical Applications

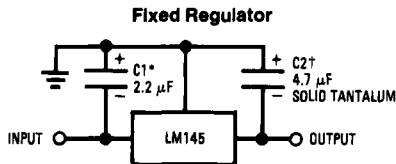

TL/H/7785-3

†Required for stability. For value given, capacitor must be solid tantalum. 50 μF aluminum electrolytic may be substituted. Values given may be increased without limit.

*Required if regulator is separated from filter capacitor. For value given, capacitor must be solid tantalum. 50 μF aluminum electrolytic may be substituted.

Typical Performance Characteristics

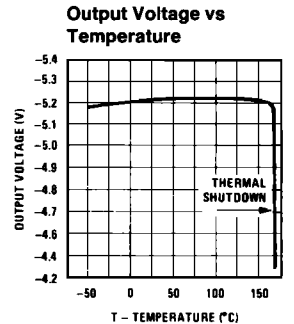
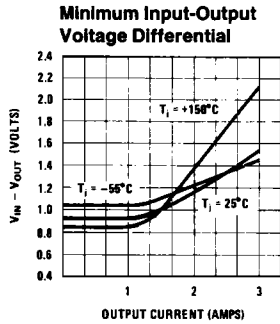
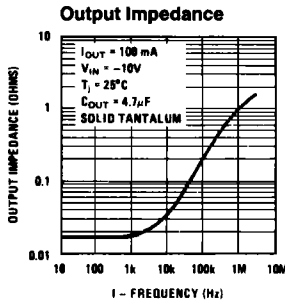
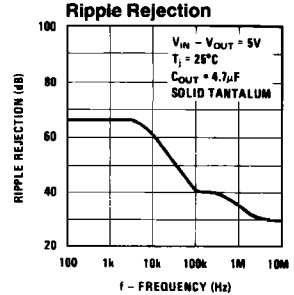
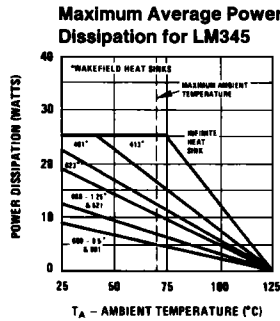
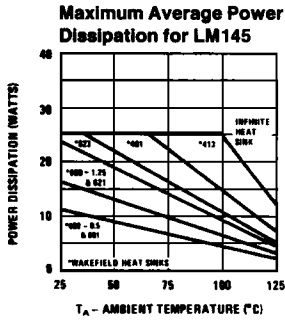

TL/H/7785-4

Typical Applications (Continued)

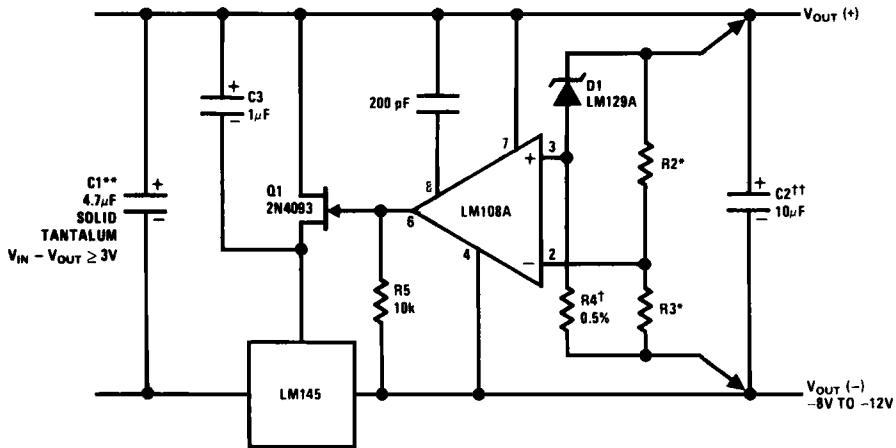

TL/H/7785-5

*Select resistors to set output voltage. 1 ppm/C tracking suggested.

**C1 is not needed if power supply filter capacitor is within 3" of regulator.

†Determines zener current. May be adjusted to minimize temperature drift.

††Solid tantalum.

Load and line regulation < 0.01%

Temperature drift < 0.001%/C

Typical Applications (Continued)

High Stability Regulator

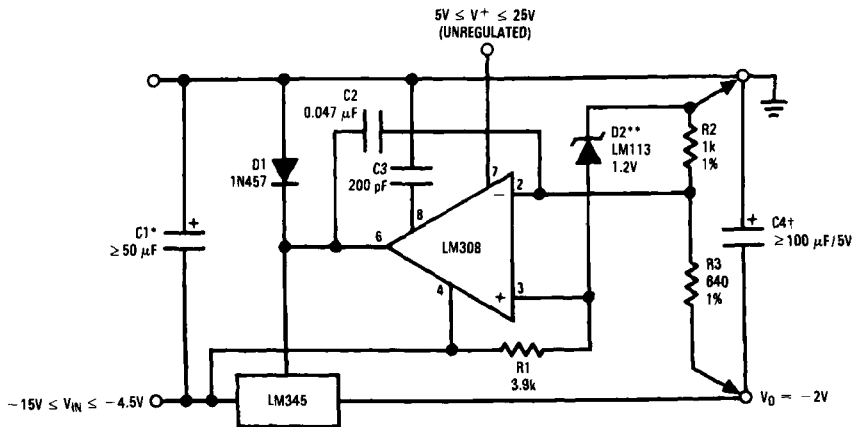

TL/H/7785-6

**C1 is not needed if power supply filter capacitor is within 3" of regulator.

†Keep C4 within 2" of LM345.

**D2 sets initial output voltage accuracy. The LM113 is available in -5, -2, and -1% tolerance.

-2V ECL Termination Regulator

Dual 3 Amp Trimmed Supply

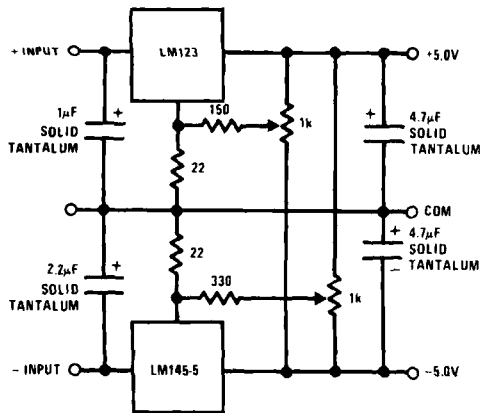

TL/H/7785-7

Variable Output (-5.0V to -15V)

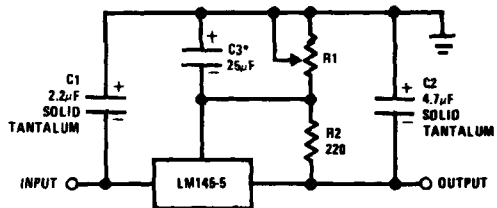

TL/H/7785-8

*Optional. Improves transient response and ripple rejection.

$$V_{OUT} = -5V \left(\frac{R1 + R2}{R2} \right)$$