



Am27C020

2 Megabit (262,144 x 8-Bit) CMOS EPROM

DISTINCTIVE CHARACTERISTICS

- **Fast access time**
 - 90 ns
- **Low power consumption**
 - 100 μ A maximum CMOS standby current
- **JEDEC-approved pinout**
 - Plug in upgrade of 1 Mbit EPROM
 - Easy upgrade from 28-pin JEDEC EPROMs
- **Single +5 V power supply**
- **$\pm 10\%$ power supply tolerance standard on most speeds**
- **100% Flashrite™ programming**
 - Typical programming time of 32 seconds
- **Latch-up protected to 100 mA from -1 V to $V_{cc} + 1$ V**
- **High noise immunity**
- **Compact 32-pin DIP package requires no hardware change for upgrades to 8 Mbits**
- **DESC SMD No. 5962-90912**

GENERAL DESCRIPTION

The Am27C020 is a 2 Mbit, ultraviolet erasable programmable read-only memory. It is organized as 256K words by 8 bits per word, operates from a single +5 V supply, has a static standby mode, and features fast single address location programming. Products are available in windowed ceramic DIP and LCC packages, as well as plastic one-time programmable (OTP) packages.

Typically, any byte can be accessed in less than 90 ns, allowing operation with high-performance microprocessors without any WAIT states. The Am27C020 offers separate Output Enable (\overline{OE}) and Chip Enable (\overline{CE})

controls, thus eliminating bus contention in a multiple bus microprocessor system.

AMD's CMOS process technology provides high speed, low power, and high noise immunity. Typical power consumption is only 100 mW in active mode, and 100 μ W in standby mode.

All signals are TTL levels, including programming signals. Bit locations may be programmed singly, in blocks, or at random. The Am27C020 supports AMD's Flashrite programming algorithm (100 μ s pulses) resulting in typical programming times of 32 seconds.

BLOCK DIAGRAM

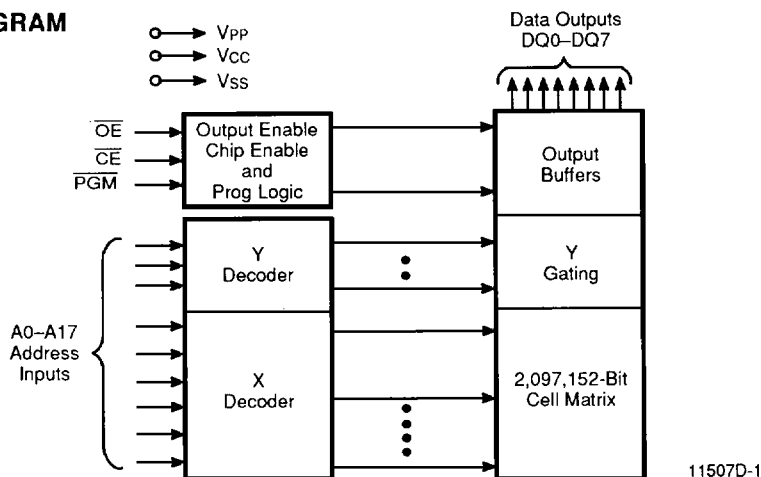

PRODUCT SELECTOR GUIDE

| Family Part No. | Am27C020 | | | | | |
|--|----------|------|------|------|------|------|
| Ordering Part No: Vcc ±5% | -95 | -105 | | | | -255 |
| Vcc ±10% | -90 | -100 | -120 | -150 | -200 | -250 |
| Max Access Time (ns) | 90 | 100 | 120 | 150 | 200 | 250 |
| \overline{CE} (\overline{E}) Access (ns) | 90 | 100 | 120 | 150 | 200 | 250 |
| \overline{OE} (\overline{G}) Access (ns) | 40 | 50 | 50 | 65 | 75 | 100 |

CONNECTION DIAGRAMS

Top View

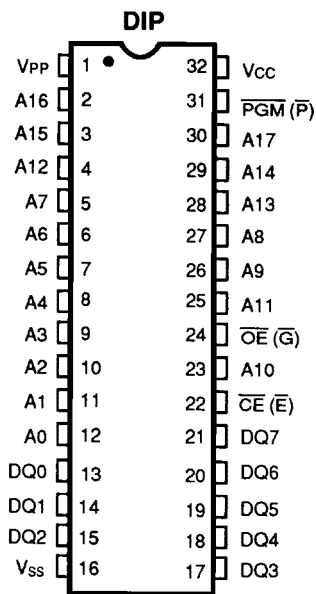

11507D-2

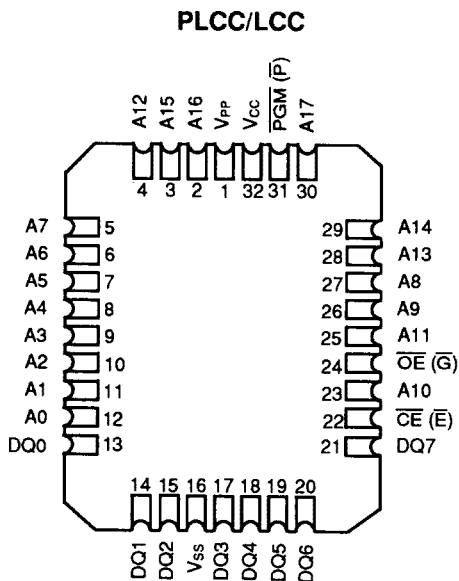

11507D-3

Notes:

1. JEDEC nomenclature is in parentheses.
2. The 32-pin DIP to 32-pin LCC configuration varies from the JEDEC 28-pin DIP to 32-pin LCC configuration.

PIN DESIGNATIONS

| | | |
|------------------------------------|---|------------------------|
| A0-A17 | = | Address Inputs |
| \overline{CE} (\overline{E}) | = | Chip Enable Input |
| DQ0-DQ7 | = | Data Input/Outputs |
| \overline{OE} (\overline{G}) | = | Output Enable Input |
| PGM (\overline{P}) | = | Program Enable Input |
| Vcc | = | Vcc Supply Voltage |
| VPP | = | Program Supply Voltage |
| VSS | = | Ground |

LOGIC SYMBOL

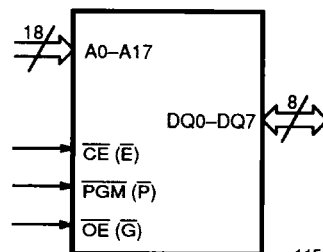

11507D-4

ORDERING INFORMATION

EPROM Products

AMD standard products are available in several packages and operating ranges. The order number (Valid Combination) is formed by a combination of:

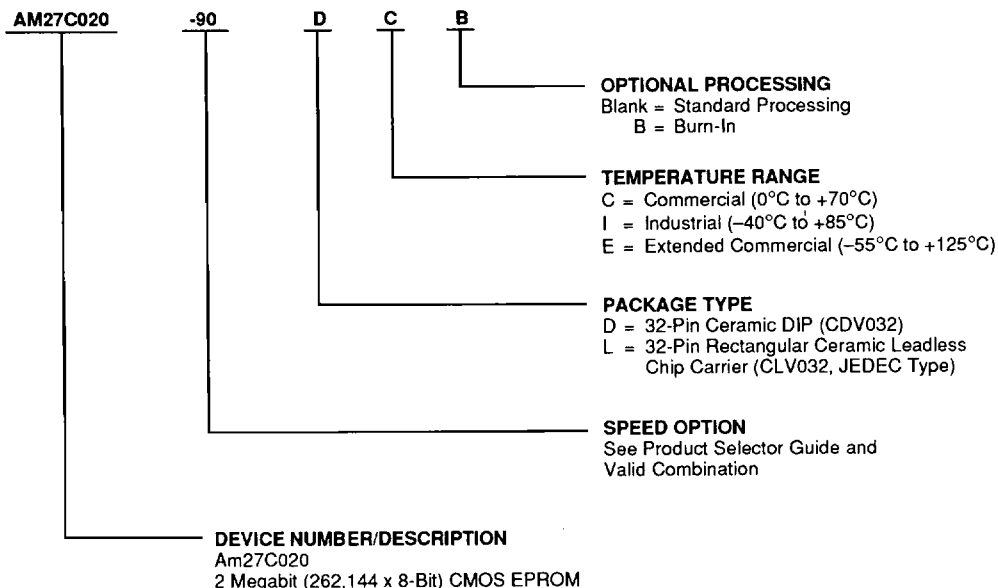

| Valid Combinations | |
|--------------------|--|
| AM27C020-90 | DC, DCB, DI, DIB, LC, LCB, LI, LIB |
| AM27C020-95 | |
| AM27C020-100 | |
| AM27C020-105 | |
| AM27C020-120 | DC, DCB, DI, DIB, DE, DEB, LCB, LIB, LE, LEB, LC, LI |
| AM27C020-150 | |
| AM27C020-200 | |
| AM27C020-255 | |
| AM27C020-255 | |

Valid Combinations

Valid Combinations list configurations planned to be supported in volume for this device. Consult the local AMD sales office to confirm availability of specific valid combinations and to check on newly released combinations.

ORDERING INFORMATION

OTP Products

AMD standard products are available in several packages and operating ranges. The order number (Valid Combination) is formed by a combination of:

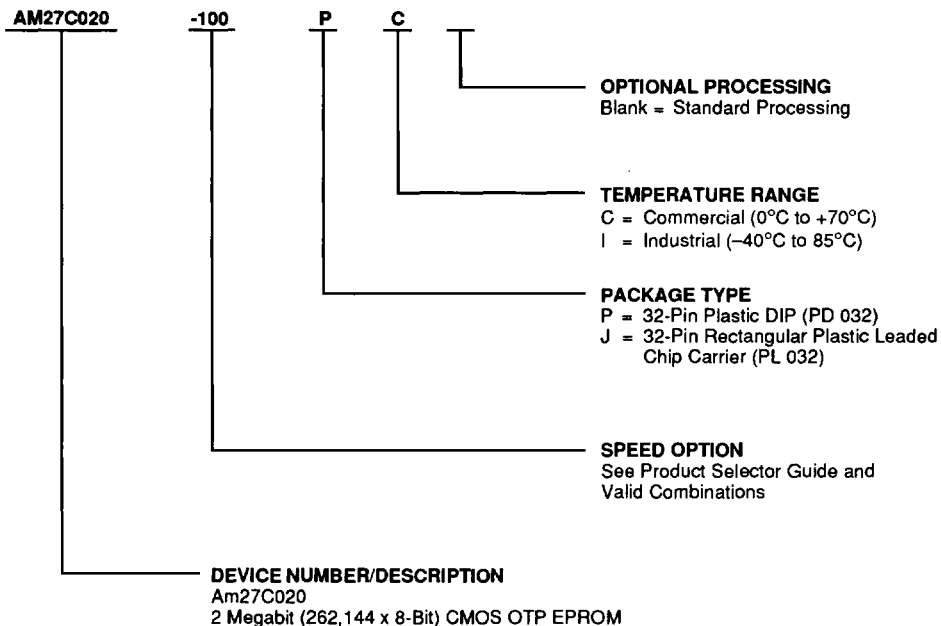

| Valid Combinations | |
|--------------------|----------------|
| AM27C020-100 | PC, JC, PI, JI |
| AM27C020-105 | |
| AM27C020-120 | |
| AM27C020-150 | |
| AM27C020-200 | |
| AM27C020-255 | |

Valid Combinations

Valid Combinations list configurations planned to be supported in volume for this device. Consult the local AMD sales office to confirm availability of specific valid combinations and to check on newly released combinations.

MILITARY ORDERING INFORMATION

APL Products

AMD products for Aerospace and Defense applications are available in several packages and operating ranges. APL (Approved Products List) products are fully compliant with MIL-STD-883 requirements. The order number (Valid Combination) is formed by a combination of:

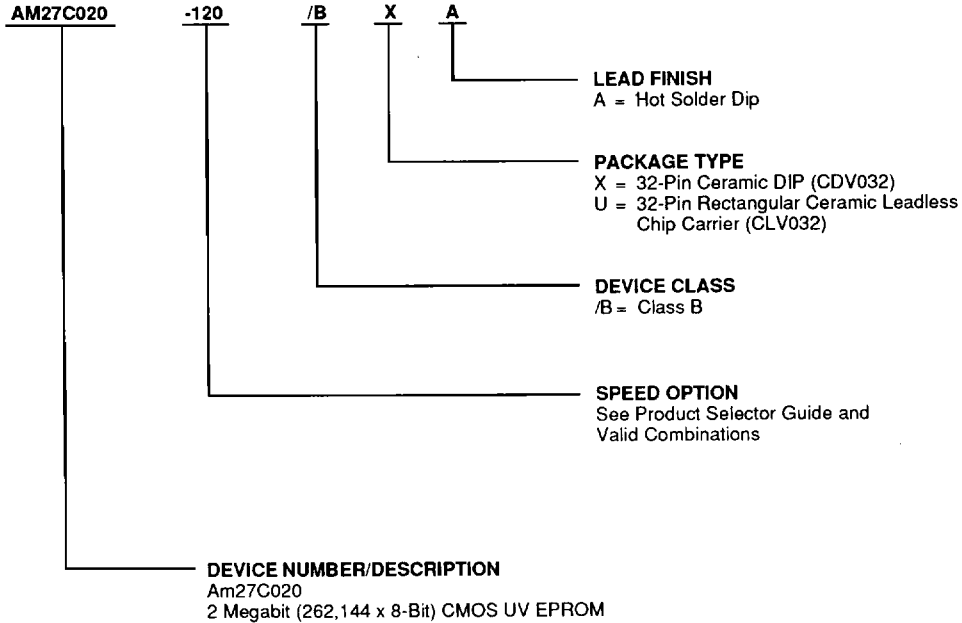

| Valid Combinations | |
|--------------------|------------|
| AM27C020-120 | /BXA, /BUA |
| AM27C020-150 | |
| AM27C020-200 | |
| AM27C020-250 | |

Valid Combinations

Valid Combinations list configurations planned to be supported in volume for this device. Consult the local AMD sales office to confirm availability of specific valid combinations and to check on newly released combinations.

Group A Tests

Group A tests consist of Subgroups 1, 2, 3, 7, 8, 9, 10, 11.

FUNCTIONAL DESCRIPTION

Erasing the Am27C020

In order to clear all locations of their programmed contents, it is necessary to expose the Am27C020 to an ultraviolet light source. A dosage of 15 W seconds/cm² is required to completely erase an Am27C020. This dosage can be obtained by exposure to an ultraviolet lamp — wavelength of 2537 Å — with intensity of 12,000 μW/cm² for 15 to 20 minutes. The Am27C020 should be directly under and about one inch from the source and all filters should be removed from the UV light source prior to erasure.

It is important to note that the Am27C020, and similar devices, will erase with light sources having wavelengths shorter than 4000 Å. Although erasure times will be much longer than with UV sources at 2537 Å, nevertheless the exposure to fluorescent light and sunlight will eventually erase the Am27C020 and exposure to them should be prevented to realize maximum system reliability. If used in such an environment, the package window should be covered by an opaque label or substance.

Programming the Am27C020

Upon delivery, or after each erasure, the Am27C020 has all 2,097,152 bits in the “ONE”, or HIGH state. “ZEROS” are loaded into the Am27C020 through the procedure of programming.

The programming mode is entered when 12.75 V ± 0.25 V is applied to the V_{PP} pin, \overline{CE} and \overline{PGM} are at V_{IL} and \overline{OE} is at V_{IH}.

For programming, the data to be programmed is applied 8 bits in parallel to the data output pins.

The Flashrite algorithm reduces programming time by using 100 μs programming pulse and by giving each address only as many pulses as are necessary in order to reliably program the data. After each pulse is applied to a given address, the data in that address is verified. If the data does not verify, additional pulses are given until it verifies or the maximum is reached. This process is repeated while sequencing through each address of the Am27C020. This part of the algorithm is done at V_{CC} = 6.25 V to assure that each EPROM bit is programmed to a sufficiently high threshold voltage. After the final address is completed, the entire EPROM memory is verified at V_{CC} = V_{PP} = 5.25 V.

Program Inhibit

Programming of multiple Am27C020s in parallel with different data is also easily accomplished. Except for \overline{CE} , all like inputs of the parallel Am27C020 may be common. A TTL low-level program pulse applied to an Am27C020 \overline{CE} input with V_{PP} = 12.75 V ± 0.25 V, \overline{PGM} LOW, and \overline{OE} HIGH will program that Am27C020.

A high-level \overline{CE} input inhibits the other Am27C020s from being programmed.

Program Verify

A verify should be performed on the programmed bits to determine that they were correctly programmed. The verify should be performed with \overline{OE} and \overline{CE} at V_{IL}, \overline{PGM} at V_{IH}, and V_{PP} between 12.5 V and 13.0 V.

Auto Select Mode

The auto select mode allows the reading out of a binary code from an EPROM that will identify its manufacturer and type. This mode is intended for use by programming equipment for the purpose of automatically matching the device to be programmed with its corresponding programming algorithm. This mode is functional in the 25°C ± 5°C ambient temperature range that is required when programming the Am27C020.

To activate this mode, the programming equipment must force 12.0 V ± 0.5 V on address line A9 of the Am27C020. Two identifier bytes may then be sequenced from the device outputs by toggling address line A0 from V_{IL} to V_{IH}. All other address lines must be held at V_{IL} during auto select mode.

Byte 0 (A0 = V_{IL}) represents the manufacturer code, and Byte 1 (A0 = V_{IH}), the device identifier code. For the Am27C020, these two identifier bytes are given in the Mode Select table. All identifiers for manufacturer and device codes will possess odd parity, with the MSB (DQ7) defined as the parity bit.

Read Mode

The Am27C020 has two control functions, both of which must be logically satisfied in order to obtain data at the outputs. Chip Enable (\overline{CE}) is the power control and should be used for device selection. Output Enable (\overline{OE}) is the output control and should be used to gate data to the output pins, independent of device selection. Assuming that addresses are stable, address access time (t_{ACC}) is equal to the delay from \overline{CE} to output (t_{CE}). Data is available at the outputs t_{OE} after the falling edge of \overline{OE} , assuming that \overline{CE} has been LOW and addresses have been stable for at least t_{ACC} - t_{OE}.

Standby Mode

The Am27C020 has a CMOS standby mode which reduces the maximum V_{CC} current to 100 μA. It is placed in CMOS-standby when \overline{CE} is at V_{CC} ± 0.3 V. The Am27C020 also has a TTL-standby mode which reduces the maximum V_{CC} current to 1.0 mA. It is placed in TTL-standby when \overline{CE} is at V_{IH}. When in standby mode, the outputs are in a high-impedance state, independent of the \overline{OE} input.

Output OR-Tieing

To accommodate multiple memory connections, a two-line control function is provided to allow for:

- Low memory power dissipation, and
- Assurance that output bus contention will not occur

It is recommended that \overline{CE} be decoded and used as the primary device-selecting function, while \overline{OE} be made a common connection to all devices in the array and connected to the READ line from the system control bus. This assures that all deselected memory devices are in their low-power standby mode and that the output pins are only active when data is desired from a particular memory device.

System Applications

During the switch between active and standby conditions, transient current peaks are produced on the rising and falling edges of Chip Enable. The magnitude of these transient current peaks is dependent on the output capacitance loading of the device. At a minimum, a 0.1 μF ceramic capacitor (high frequency, low inherent inductance) should be used on each device between V_{CC} and V_{SS} to minimize transient effects. In addition, to overcome the voltage drop caused by the inductive effects of the printed circuit board traces on EPROM arrays, a 4.7 μF bulk electrolytic capacitor should be used between V_{CC} and V_{SS} for each eight devices. The location of the capacitor should be close to where the power supply is connected to the array.

MODE SELECT TABLE

| Mode | | Pins | \overline{CE} | \overline{OE} | \overline{PGM} | A0 | A9 | V_{PP} | Outputs |
|-------------------------|-------------------|------|---------------------------|-----------------|------------------|-----------------|----------------|----------|---------|
| Read | | | V _{IL} | V _{IL} | X | X | X | X | DOUT |
| Output Disable | | | V _{IL} | V _{IH} | X | X | X | X | High Z |
| Standby (TTL) | | | V _{IH} | X | X | X | X | X | High Z |
| Standby (CMOS) | | | $V_{CC} \pm 0.3\text{ V}$ | X | X | X | X | X | High Z |
| Program | | | V _{IL} | V _{IH} | V _{IL} | X | X | V_{PP} | DIN |
| Program Verify | | | V _{IL} | V _{IL} | V _{IH} | X | X | V_{PP} | DOUT |
| Program Inhibit | | | V _{IH} | X | X | X | X | V_{PP} | High Z |
| Auto Select (Note 3) | Manufacturer Code | | V _{IL} | V _{IL} | X | V _{IL} | V _H | X | 01H |
| | Device Code | | V _{IL} | V _{IL} | X | V _{IH} | V _H | X | 97H |

Notes:

1. $V_H = 12.0\text{ V} \pm 0.5\text{ V}$
2. X can be either V_{IL} or V_{IH}
3. A1–A8 = A10–A17 = V_{IL}

ABSOLUTE MAXIMUM RATINGS

| | |
|------------------------------------|----------------------------|
| Storage Temperature: | |
| OTP Products | -65°C to +125°C |
| All Other Products | -65°C to +150°C |
| Ambient Temperature | |
| with Power Applied | -55°C to +125°C |
| Voltage with Respect to V_{SS} : | |
| All pins except A9, V_{PP} , and | |
| V_{CC} (Note 1) | -0.6 V to $V_{CC} + 0.6$ V |
| A9 and V_{PP} (Note 2) | -0.6 V to 13.5 V |
| V_{CC} | -0.6 V to 7.0 V |

Notes:

1. During transitions, the input may overshoot V_{SS} to -2.0 V for periods of up to 20 ns. Maximum DC voltage on input and I/O may overshoot to $V_{CC} + 2.0$ V for periods of up to 20 ns.
2. During transitions, A9 and V_{PP} may overshoot V_{SS} to -2.0 V for periods of up to 20 ns. A9 and V_{PP} must not exceed 13.5 V for any period of time.

Stresses above those listed under Absolute Maximum Ratings may cause permanent device failure. Functionality at or above these limits is not implied. Exposure to absolute maximum ratings for extended periods may affect device reliability.

OPERATING RANGES**Commercial (C) Devices**

Case Temperature (T_c) 0°C to +70°C

Industrial (I) Devices

Case Temperature (T_c) -40°C to +85°C

Extended Commercial (E) Devices

Case Temperature (T_c) -55°C to +125°C

Military (M) Devices

Case Temperature (T_c) -55°C to +125°C

Supply Read Voltages:

V_{CC} for Am27C020-XX5 +4.75 V to +5.25 V

V_{CC} for Am27C020-XX0 +4.50 V to +5.50 V

Operating ranges define those limits between which the functionality of the device is guaranteed.

**DC CHARACTERISTICS over operating ranges unless otherwise specified
(Notes 1, 2 and 4) (for APL products, Group A, Subgroups 1, 2, 3, 6 and 7 are tested unless otherwise noted)**

| PRELIMINARY | | | | | |
|------------------|---|--|------|-----------------------|------|
| Parameter Symbol | Parameter Description | Test Conditions | Min | Max | Unit |
| V _{OH} | Output HIGH Voltage | I _{OH} = -400 μA | 2.4 | | V |
| V _{OL} | Output LOW Voltage | I _{OL} = 2.1 mA | | 0.45 | V |
| V _{IH} | Input HIGH Voltage | | 2.0 | V _{CC} + 0.5 | V |
| V _{IL} | Input LOW Voltage | | -0.5 | +0.8 | V |
| I _{LI} | Input Load Current | V _{IN} = 0 V to V _{CC} | | 1.0 | μA |
| I _{LO} | Output Leakage Current | V _{OUT} = 0 V to V _{CC} | | 5.0 | μA |
| I _{CC1} | V _{CC} Active Current (Note 3) | $\overline{OE} = V_{IL}$, f = 5 MHz, I _{OUT} = 0 mA | | | μA |
| | | C/I Devices | | 30 | |
| | | E/M Devices | | 60 | |
| I _{CC2} | V _{CC} TTL Standby Current | $\overline{OE} = V_{IH}$, $\overline{OE} = V_{IL}$ | | 1.0 | mA |
| I _{CC3} | V _{CC} CMOS Standby Current | $\overline{OE} = V_{CC} + 0.3$ V | | 100 | μA |
| I _{PP1} | V _{PP} Supply Current (Read) | $\overline{OE} = \overline{OE} = V_{IL}$, V _{PP} = V _{CC} | | 100 | μA |

Notes:

1. V_{CC} must be applied simultaneously or before V_{PP}, and removed simultaneously or after V_{PP}.
2. **Caution:** The Am27C020 must not be removed from (or inserted into) a socket when V_{CC} or V_{PP} is applied.
3. I_{CC1} is tested with $\overline{OE}/V_{PP} = V_{IH}$ to simulate open outputs.
4. Minimum DC Input Voltage is -0.5 V. During transitions, the inputs may overshoot to -2.0 V for periods less than 20 ns. Maximum DC Voltage on output pins is V_{CC} + 0.5 V, which may overshoot to V_{CC} + 2.0 V for periods less than 20 ns.

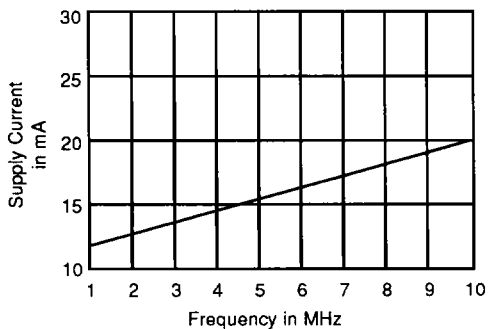

11507D-5

Figure 1. Typical Supply Current vs. Frequency
V_{CC} = 5.5 V, T = 25°C

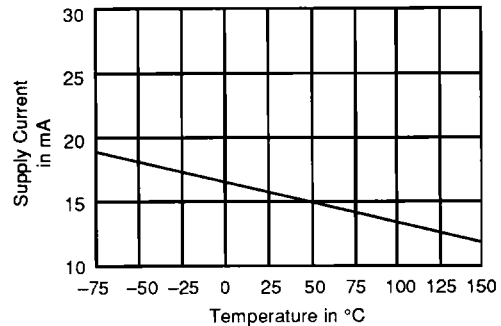

11507D-6

Figure 2. Typical Supply Current vs. Temperature
V_{CC} = 5.5 V, f = 5 MHz

CAPACITANCE

| Parameter Symbol | Parameter Description | Test Conditions | CDV032 | | CLV032 | | PD 032 | | PL 032 | | Unit |
|------------------|-----------------------|------------------------|--------|-----|--------|-----|--------|-----|--------|-----|------|
| | | | Typ | Max | Typ | Max | Typ | Max | Typ | Max | |
| C _{IN} | Input Capacitance | V _{IN} = 0 V | 10 | 12 | 8 | 10 | 10 | 12 | 8 | 10 | pF |
| C _{OUT} | Output Capacitance | V _{OUT} = 0 V | 12 | 15 | 9 | 12 | 12 | 15 | 9 | 12 | pF |

Notes:

1. This parameter is only sampled and not 100% tested.
2. T_A = +25°C, f = 1 MHz.

SWITCHING CHARACTERISTICS over operating ranges unless otherwise specified (Notes 1, 3 and 4) (for APL products, Group A, Subgroups 9, 10 and 11 are tested unless otherwise noted)

| Parameter Symbols | | Parameter Description | Test Conditions | Am27C020 | | | | | | Unit | |
|--|-----------------------------|---|--|------------|--------------|------|------|------|--------------|------|----|
| JEDEC | Standard | | | -95 -90 | -105 -100 | -120 | -150 | -200 | -255 -250 | | |
| t _{AVQV} | t _{ACC} | Address to Output Delay | $\overline{CE} = \overline{OE} = V_{IL}$ | Min | | | | | | | ns |
| | | | | Max | 90 | 100 | 120 | 150 | 200 | 250 | |
| t _{ELQV} | t _{CE} | Chip Enable to Output Delay | $\overline{OE} = V_{IL}$ | Min | | | | | | | ns |
| | | | | Max | 90 | 100 | 120 | 150 | 200 | 250 | |
| t _{GLQV} | t _{OE} | Output Enable to Output Delay | $\overline{CE} = V_{IL}$ | Min | | | | | | | ns |
| | | | | Max | 40 | 50 | 50 | 55 | 60 | 75 | |
| t _{EHQZ} , t _{GHOZ} | t _{DF} (Note 2) | Chip Enable HIGH or Output Enable HIGH, whichever comes first, to Output Float | | Min | - | - | - | - | - | - | ns |
| | | | | Max | 25 | 30 | 30 | 30 | 40 | 60 | |
| t _{AXQX} | t _{OH} | Output Hold from Addresses, \overline{CE} , or \overline{OE} , whichever occurred first | | Min | 0 | 0 | 0 | 0 | 0 | 0 | ns |
| | | | | Max | | | | | | | |

Notes:

1. V_{CC} must be applied simultaneously or before V_{PP}, and removed simultaneously or after V_{PP}.
2. This parameter is only sampled and not 100% tested.
3. **Caution:** The Am27C020 must not be removed from, or inserted into a socket or board when V_{PP} or V_{CC} is applied.
4. Output Load: 1 TTL gate and C_L = 100 pF.
 Input Rise and Fall Times: 20 ns,
 Input Pulse Levels: 0.45 V to 2.4 V,
 Timing Measurement Reference Level—Inputs: 0.8 V and 2 V,
 Outputs: 0.8 V and 2 V

SWITCHING TEST CIRCUIT

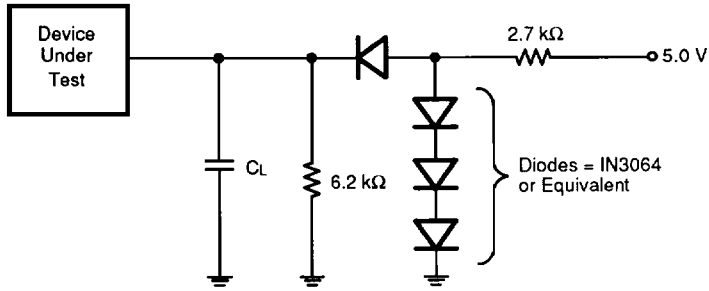

11507D-7

$C_L = 100 \text{ pF}$ including jig capacitance

SWITCHING TEST WAVEFORM

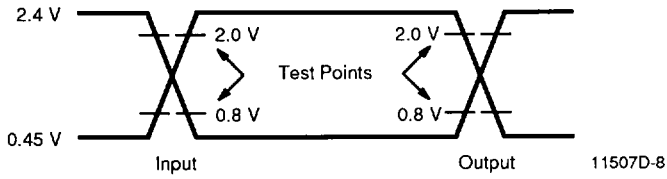

11507D-8

AC Testing: Inputs are driven at 2.4 V for a Logic "1" and 0.45 V for a Logic "0." Input pulse rise and fall times are $\leq 20 \text{ ns}$.

KEY TO SWITCHING WAVEFORMS

| WAVEFORM | INPUTS | OUTPUTS |
|----------|----------------------------------|---|
| | Must Be Steady | Will Be Steady |
| | May Change from H to L | Will Be Changing from H to L |
| | May Change from L to H | Will Be Changing from L to H |
| | Don't Care, Any Change Permitted | Changing, State Unknown |
| | Does Not Apply | Center Line is High Impedance "Off" State |

KS000010

SWITCHING WAVEFORM

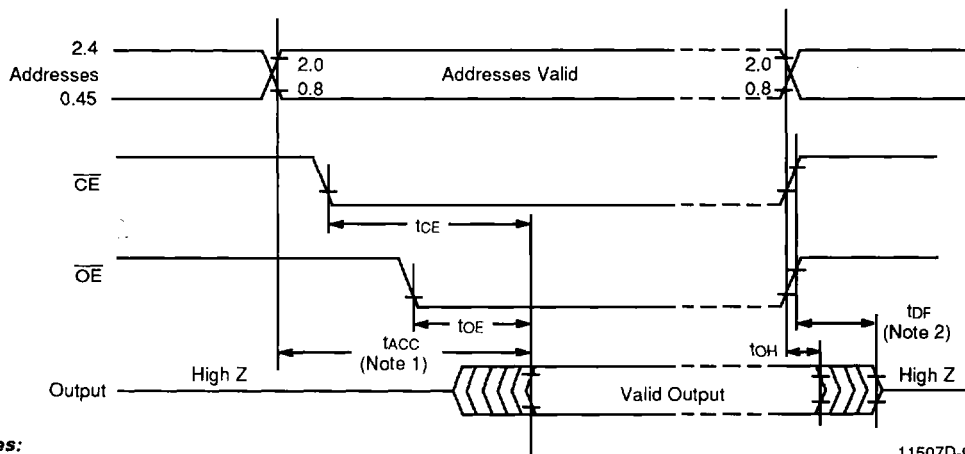

Notes:

- \overline{OE} may be delayed up to $t_{ACC} - t_{OE}$ after the falling edge of the addresses without impact on t_{ACC} .
- t_{DF} is specified from \overline{OE} or \overline{CE} , whichever occurs first.

11507D-9