

THIS DRAWING IS UNPUBLISHED. RELEASED FOR PUBLICATION  
 © COPYRIGHT BY TYCO ELECTRONICS CORPORATION. ALL RIGHTS RESERVED.

LOC	DIST	REVISIONS					
AF	50	P	LTR	DESCRIPTION	DATE	DWN	APVD
			S	REV PER 0G3A-0734-04	16SEP04	JR	PD

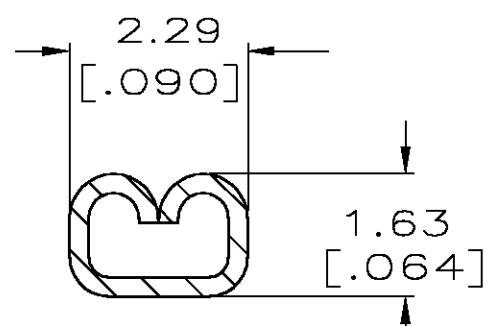

SECTION A-A  
SCALE 10:1

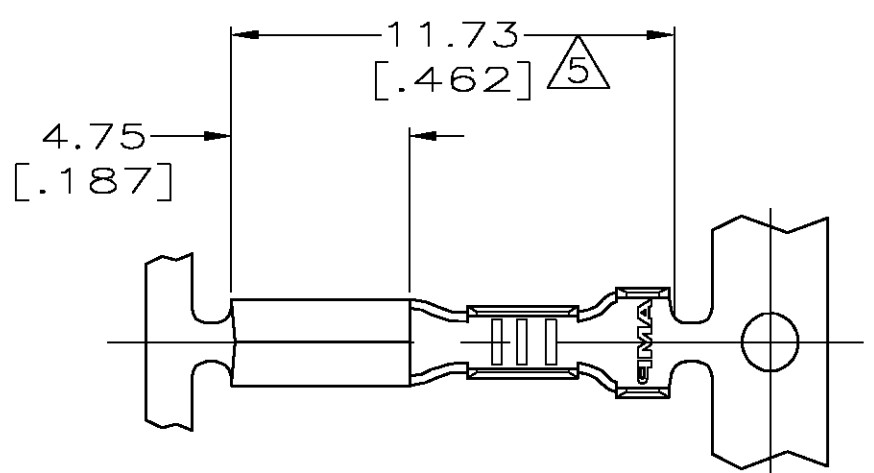
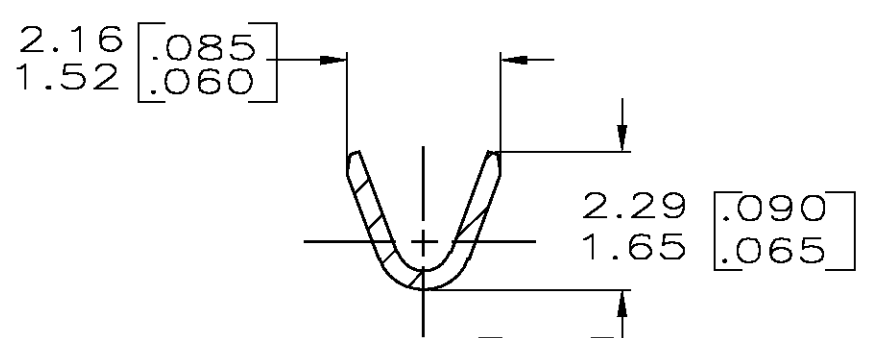
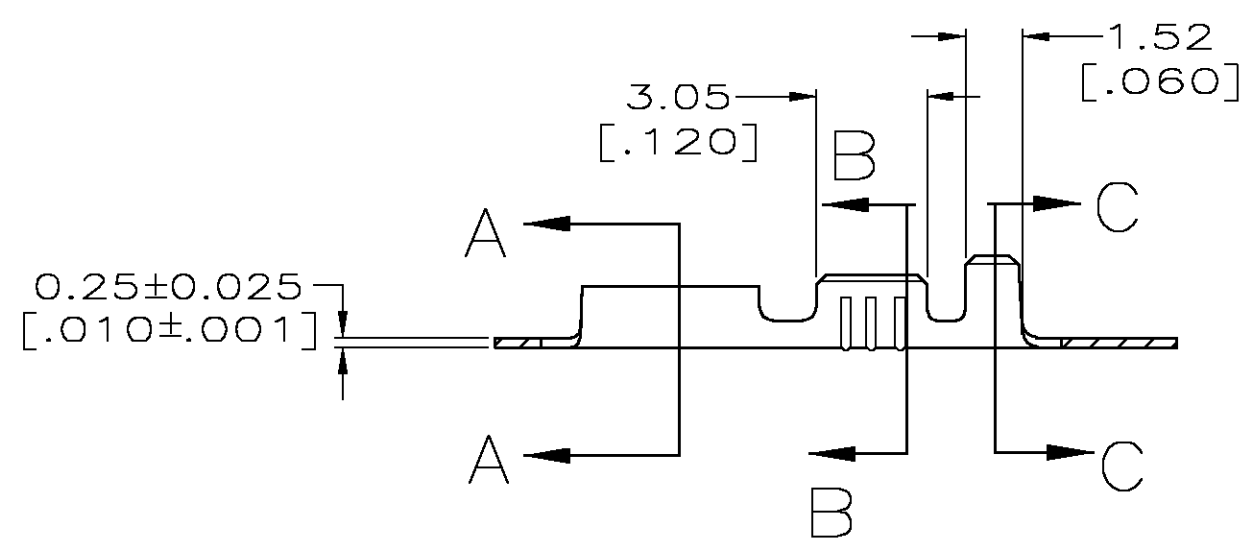

SECTION B-B  
SCALE 10:1

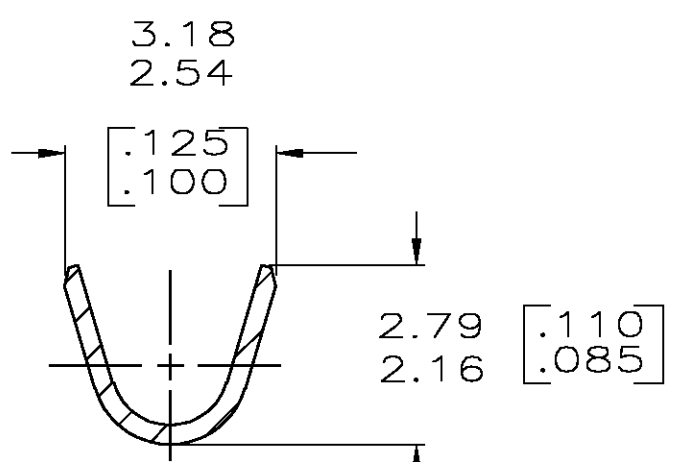

SECTION C-C  
SCALE 10:1

- 1 CONTINUOUS STRIP ON REELS.
- 2 FEED IS 8.89±0.13 [.350±.005]
- △3 TIN PLATE 0.002032 [.000080] MIN.
- △4 GOLD PLATE 0.000381 [.000015] MIN OVER 0.000762 [.000030] MIN THK NICKEL.
- △5 GOLD PLATE REQUIRED IN THIS AREA ONLY.
- △6 REVERSE REELING.
- 7 MAX TEST TAB MUST ENTER & WITHDRAW FROM RECPT. WITH A MAX FORCE OF 11 LBS. (USE GAGE 100716-40). MIN TEST TAB MUST WITHDRAW FROM RECPT WITH MIN PULL OF 1 LB AFTER MAX TAB HAS BEEN INSERTED & WITHDRAWN 3 TIMES.

△6	GOLD △4	1.02-2.03 DIA [.040-.080] DIA	[#24-#20] AWG	±0.025 0.79 X 1.58 ±.001 [.031 X .062]	60900-5
△6	△3 TIN				60900-4
	-				60900-3
	GOLD △4				60900-2
	△3 TIN				60900-1
	FINISH	INSULATION RANGE	WIRE SIZE	MATING TAB THK	PART NO.

THIS DRAWING IS A CONTROLLED DOCUMENT.		DWN JR RUTH 1/24/95	Tyco Electronics Corporation Harrisburg, Pa 17105-3608		
DIMENSIONS: INCHES		CHK MS FEHER 1/24/95			
TOLERANCES UNLESS OTHERWISE SPECIFIED:		APVD R REINER 1/24/95	NAME RECEPTACLE, TAB, WRAP TYPE		
0 PLC ± - 1 PLC ± - 2 PLC ± 0.25 [.010] 3 PLC ± - 4 PLC ± - ANGLES ± -		PRODUCT SPEC -	-		
MATERIAL H04 BRASS		FINISH SEE TABLE	APPLICATION SPEC -	-	
		WEIGHT -	SIZE A3	CAGE CODE 00779	DRAWING NO C-60900
CUSTOMER DRAWING			RESTRICTED TO -	SCALE 5:1	SHEET 1 OF 1
			REV S		