

## 1702/1703

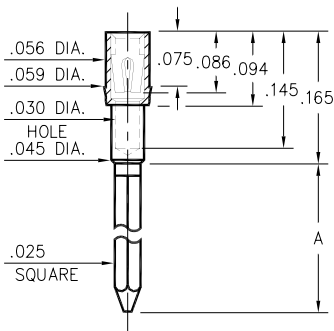

Basic Part Number	# of Wraps	Length A
1702-2	2	.370
1703-3	3	.510

**170X-X-17-XX-30-XX-02-0**  
Press-fit in .057 mounting hole

## 0038⇒0040/0066⇒0068

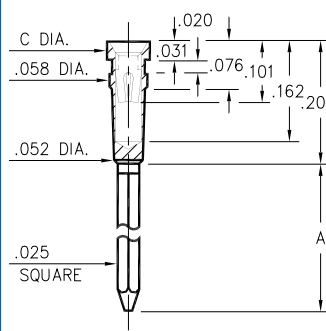

Basic Part #	# of Wraps	Length A	Dia. C
0040-1	1	.260	
0039-2	2	.360	.072
0038-3	3	.500	
0068-1	1	.260	
0067-2	2	.360	.062
0066-3	3	.500	

**00XX-X-17-XX-30-XX-02-0**  
Press-fit in .055 mounting hole

## 0086/0088/0089

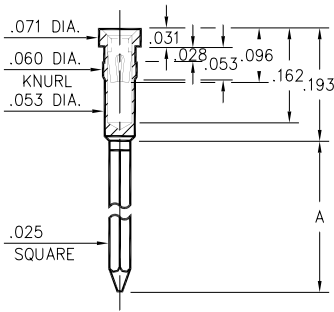

Basic Part Number	# of Wraps	Length A
0089-2	2	.370
0088-3	3	.510
0086-4	4	.630

**008X-X-17-XX-3X-XX-02-0**  
Press-fit in .057 mounting hole

## 1030⇒1036

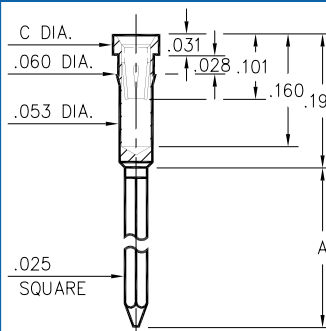

Basic Part #	# of Wraps	Length A	Dia. C
1032-1	1	.260	
1031-2	2	.360	.072
1030-3	3	.510	
1036-1	1	.260	
1035-2	2	.360	.062
1034-3	3	.510	

**103X-X-17-XX-3X-XX-02-0**  
Press-fit in .057 mounting hole

## 1045

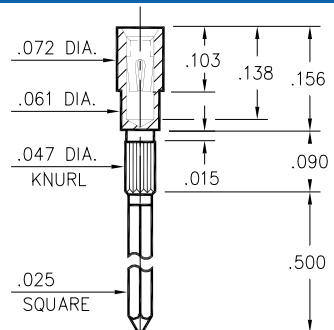

**1045-3-17-XX-30-XX-02-0**  
Press-fit in .043 mounting hole

## 1040

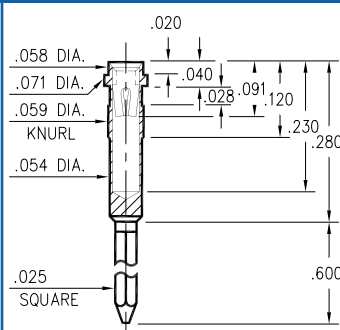

**1040-3-17-XX-30-XX-02-0**  
Press-fit in .056 mounting hole

### SPECIFICATIONS

**SHELL MATERIAL:**  
Brass Alloy 360, 1/2 Hard

**CONTACT MATERIAL:**  
Beryllium Copper Alloy 172, HT

**DIMENSION IN INCHES**  
**TOLERANCES ON:**  
LENGTHS: ±.005  
DIAMETERS: ±.002  
ANGLES: ± 2°

**ORDER CODE: XXXX - X - 17 - XX - 3X - XX - 02 - 0**

**BASIC PART #** →

**SPECIFY SHELL FINISH:** →

**01** 200μ" TIN/LEAD OVER NICKEL  
**15** 10μ" GOLD OVER NICKEL

**SPECIFY CONTACT FINISH:** →

**02** 200μ" TIN/LEAD OVER NICKEL  
**14** 10μ" GOLD OVER NICKEL  
**27** 30μ" GOLD OVER NICKEL

↑  
**SELECT CONTACT**

**#30 OR #32 CONTACT (DATA ON PAGE 208)**