

Fig. 1

- The unique compliant tail pins conform to .040" ±.003 finished hole without stressing inner layers.
- Pin headers are offered in two tail lengths for .060"-.100" (MM# 5601) and .090"-.130" (MM# 5602) thick panels. (See page 178 for details)
- Sockets use Hi-Rel, six-finger clips which accept .030" dia. pins and also .025" square pins. (MM# 4614 or 4615). (See page 147 for details)

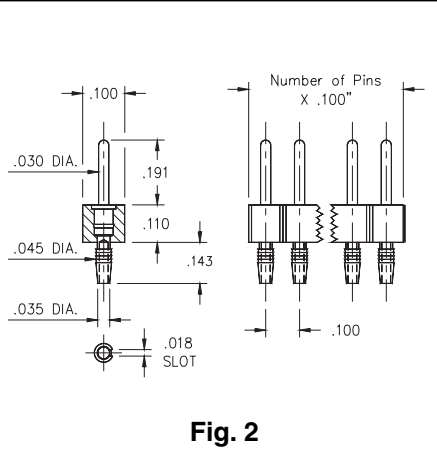

Fig. 2

Ordering Information

Fig. 1

**Compliant Tail Pin Header
for .060 - .100" thick boards**

800-XX-0 __ -61-001

Specify # of pins ↪ 01-64

Fig. 2

**Compliant Tail Pin Header
for .090 - .130" thick boards**

800-XX-0 __ -62-001

Specify # of pins ↪ 01-64

XX=
Plating Code See Below

SPECIFY PLATING CODE XX=	10	90		
Pin Plating	10µ" Au	200µ" Sn/Pb		

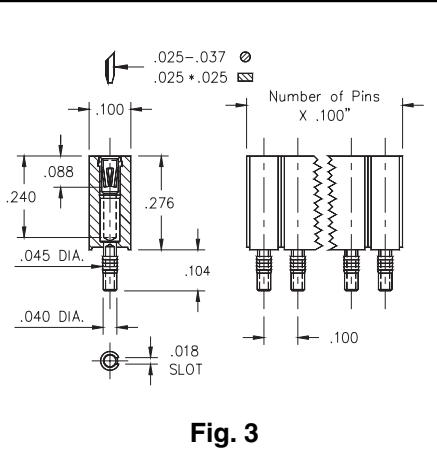

Fig. 3

Fig. 3

**Compliant Tail Socket
for .060 - .100" thick boards**

801-XX-0 __ -61-001

Specify # of pins ↪ 01-50

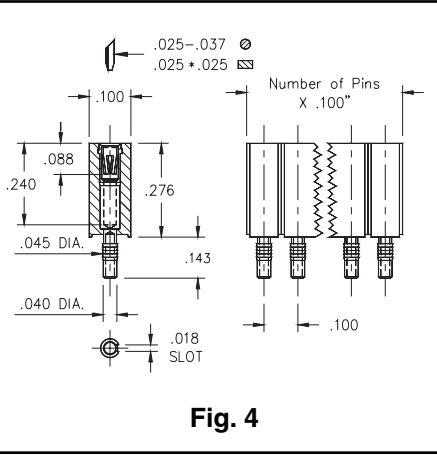

Fig. 4

Fig. 4

**Compliant Tail Socket
for .090 - .130" thick boards**

801-XX-0 __ -62-001

Specify # of pins ↪ 01-50

XX=
Plating Code See Below

SPECIFY PLATING CODE XX=		93	99
Sleeve (Pin)		200µ" Sn/Pb	200µ" Sn/Pb
Contact (Clip)		30µ" Au	200µ" Sn/Pb