

ASSP

BIPOLAR

SWITCHING REGULATOR CONTROLLER

MB3769A

■ DESCRIPTION

The Fujitsu Microelectronics MB3769A is a pulse-width-modulation controller which is applied to fixed frequency pulse modulation technique. The MB3769A contains wide band width Op-Amp and high speed comparator to construct very high speed switching regulator system up to 700 kHz. Output is suitable for power MOS FET drive owing to adoption of totem pole output.

The MB3769A provides stand-by mode at low voltage power supply when it is applied in primary control system.

■ FEATURES

- High frequency oscillator ($f = 1 \text{ kHz to } 700 \text{ kHz}$)
- On-chip wide band frequency operation amplifier ($BW = 8 \text{ MHz Typ}$)
- On-chip high speed comparator ($t_d = 120 \text{ ns Typ}$)
- Internal reference voltage generator provides a stable reference supply ($5 \text{ V} \pm 2\%$)
- Low power dissipation (1.5 mA Typ at standby mode, 8 mA Typ at operating mode)
- Output current $\pm 100 \text{ mA}$ ($\pm 600 \text{ mA}$ at peak)
- High speed switching operation ($t_r = 60 \text{ ns}$, $t_f = 30 \text{ ns}$, $C_L = 1000 \text{ pF Typ}$)
- Adjustable Dead-time
- On-chip soft start and quick shut down functions
- Internal circuitry prohibits double pulse at dynamic current limit operation
- Under voltage lock out function (OFF to ON: 10 V Typ , ON to OFF: 8 V Typ)
- On-chip output shut down circuit with latch function at over voltage
- On-chip Zener diode (15 V)
- One type of package (SOP-16pin : 1 type)

■ APPLICATIONS

- Power supply module
- Industrial Equipment
- AC/DC Converter etc.

MB3769A

■ PIN ASSIGNMENT

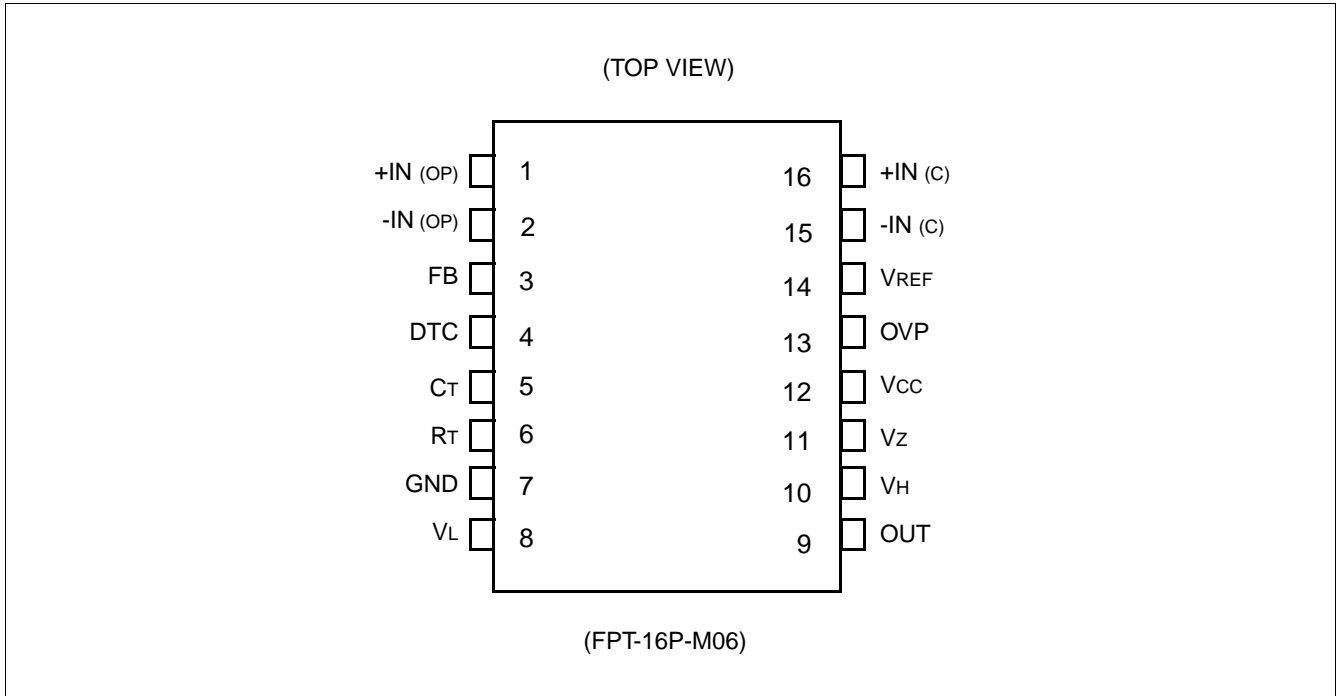

■ BLOCK DIAGRAM

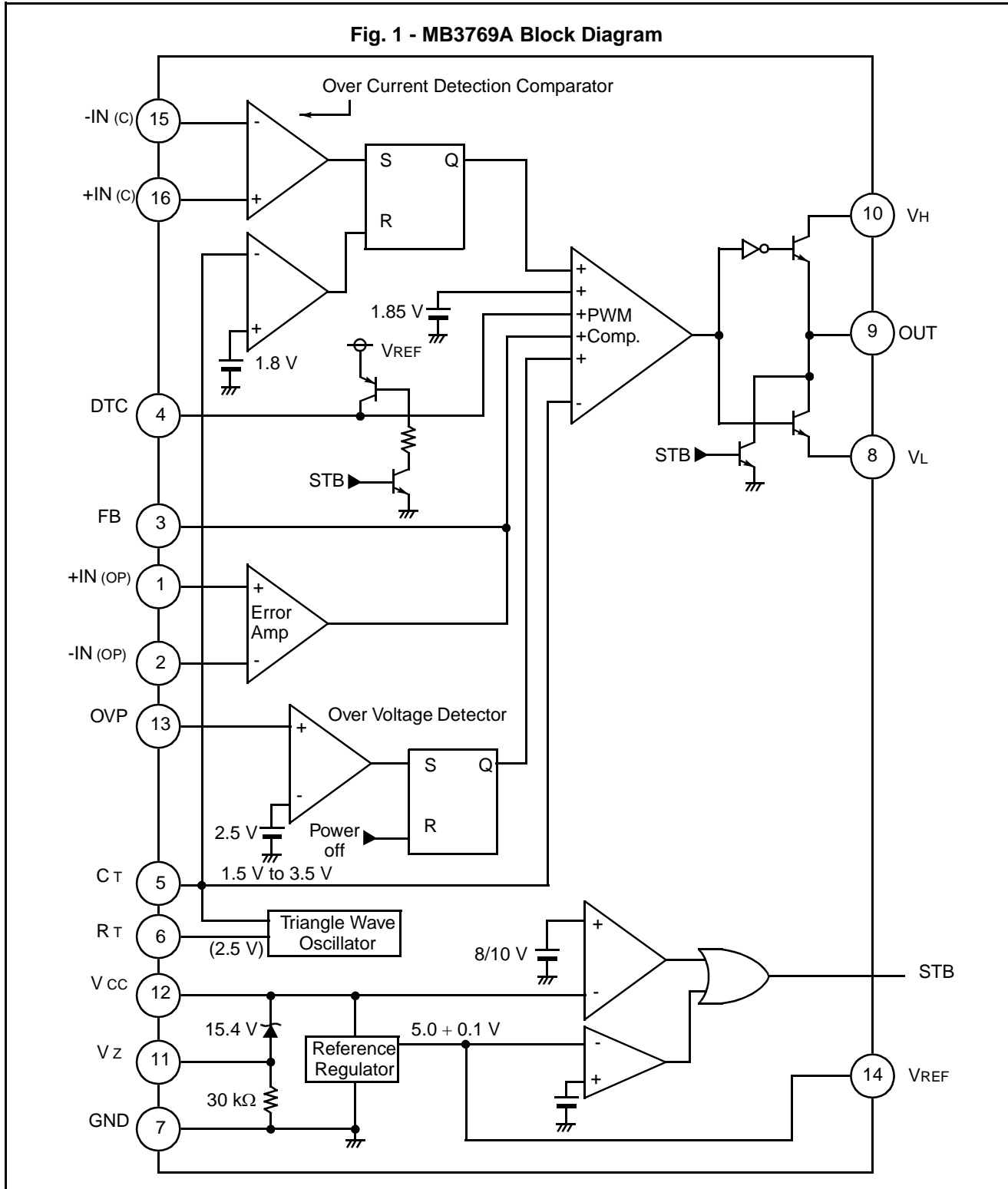

MB3769A

■ ABSOLUTE MAXIMUM RATINGS

Parameter	Symbol	Rating		Unit
		Min	Max	
Power Supply Voltage	VCC	—	20	V
Output Current	IOUT	—	120 (660*1)	mA
Operation Amp Input Voltage	Vin (OP)	—	VCC + 0.3 (≤ 20)	V
Power Dissipation : SOP	PD	—	620*2	mW
Storage Temperature	TSTG	-55	+125	°C

*1 : Duty $\leq 5\%$

*2 : Ta = + 25 °C, SOP package is mounted on the epoxy board. (4 cm x 4 cm x 0.15 cm)

WARNING: Semiconductor devices can be permanently damaged by application of stress (voltage, current, temperature, etc.) in excess of absolute maximum ratings. Do not exceed these ratings.

■ RECOMMENDED OPERATING CONDITIONS

Parameter	Symbol	SOP package			Unit
		Min	Typ	Max	
Power Supply Voltage	V _{CC}	12	15	18	V
Output Current (DC)	I _{OUT}	-100	-	+100	mA
Output Current (Peak)	I _{OUT PEAK}	-600	-	+600	mA
Operation Amp Input voltage	V _{INOP}	-0.2	0 to V _{REF}	V _{CC} -3	V
FB Sink Current	I _{SINK}	-	-	0.3	mA
FB Source Current	I _{SOURCE}	-	-	2	mA
Comparator Input Voltage	V _{INC+}	-0.3	0 to 3	V _{CC}	V
	V _{INC-}	-0.3	0 to 2	2.5	V
Reference Section Output Current	I _{REF}	-	2	10	mA
Timing Resistor	R _T	9	18	50	kΩ
Timing Capacitor	C _T	100	680	10 ⁶	pF
Oscillator Frequency	f _{OSC}	1	100	700	kHz
Zener Current	I _Z	-	-	5	mA
Operating Ambient Temperature: SOP	T _a	-30	+25	+75	°C

WARNING: The recommended operating conditions are required in order to ensure the normal operation of the semiconductor device. All of the device's electrical characteristics are warranted when the device is operated within these ranges.

Always use semiconductor devices within their recommended operating condition ranges. Operation outside these ranges may adversely affect reliability and could result in device failure.

No warranty is made with respect to uses, operating conditions, or combinations not represented on the data sheet. Users considering application outside the listed conditions are advised to contact their representatives beforehand.

MB3769A

■ ELECTRICAL CHARACTERISTICS

(V_{CC}=15V, T_a=+25°C)

Parameter		Symbol	Condition	Value			Unit	
				Min	Typ	Max		
Reference Section	Output Voltage	V _{REF}	I _{REF} = 1 mA	4.9	5.0	5.1	V	
	Input Regulation	ΔV _{RIN}	12 V ≤ V _{CC} ≤ 18 V	-	2	15	mV	
	Load Regulation	ΔV _{RLD}	1 mA ≤ I _{REF} ≤ 10 mA	-	-1	-15	mV	
	Temp. Stability	ΔV _{RTEMP}	-30 °C ≤ T _a ≤ +85 °C	-	±200	±750	μV/°C	
	Short Circuit Output Current	I _{SC}	V _{REF} = 0 V	15	40	-	mA	
Oscillator Section	Oscillator Frequency	f _{OSC}	R _T = 18 kΩ C _T = 680 pF	90	100	110	kHz	
	Voltage Stability	Δf _{OSCIN}	12 V ≤ V _{CC} ≤ 18 V	-	±0.03	-	%	
	Temp. Stability	Δf _{OSC} / ΔT	-30 °C ≤ T _a ≤ +85 °C	-	±2	-	%	
Dead-time Control Section	Input Bias Current	I _D	-	-	2	10	μA	
	Max. Duty Cycle	D _{max}	V _d = 1.5 V	75	80	85	%	
	Duty Cycle Set	D _{set}	V _d = 0.5 V _{REF}	45	50	55	%	
	Input Threshold Voltage	0% Duty Cycle	V _{DO}	-	-	3.5	3.8	V
		Max. Duty Cycle	V _{DM}	-	1.55	1.85	-	V
Discharge Voltage	V _{DH}	V _{CC} = 7 V, I _{DTC} = -0.3 mA	4.5	-	-	V		
Error Amplifier Section	Input Offset Voltage	V _{IO(OP)}	V ₃ = 2.5 V	-	±2	±10	mV	
	Input Offset Current	I _{IO(OP)}	V ₃ = 2.5 V	-	±30	±300	nA	
	Input Bias Current	I _{IR(OP)}	V ₃ = 2.5 V	-1	-0.3	-	μA	
	Common-Mode Input Voltage	V _{CM(OP)}	12 V ≤ V _{CC} ≤ 18 V	-0.2	-	V _{CC} -3	V	
	Voltage Gain	A _{V(OP)}	0.5 V ≤ V ₃ ≤ 4 V	70	90	-	dB	
	Band Width	BW	A _V = 0 dB	-	8	-	MHz	
	Slew Rate	SR	R _L = 10 kΩ, A _V = 0 dB	-	6	-	V/μs	
	Common-Mode Rejection Rate	CMR	V _{IN} = 0 V to 10 V	65	80	-	dB	
	"H" Level Output Voltage	V _{OH}	I ₃ = -2 mA	4.0	4.6	-	V	
	"L" Level Output Voltage	V _{OL}	I ₃ = 0.3 mA	-	0.1	0.5	V	

(Continued)

(Continued)

(V_{CC}=15V, T_a=+25°C)

Parameter	Symbol	Condition	Value			Unit	
			Min	Typ	Max		
Current Comparator	Input Offset Voltage	V _{IO (C)}	V _{IN} = 1 V	-	±5	±15	mV
	Input Bias Current	I _{IB (C)}	V _{IN} = 1 V	-5	-1	-	μA
	Common-Mode Input Voltage	V _{CM (C)}	-	0	-	2.5	V
	Voltage Gain	A _{V (C)}	-	-	200	-	V/V
	Response Time	t _d	50 mV over drive	-	120	250	ns
PWM Comparator Section	0% Duty Cycle	V _{OPO}	R _T = 18 kΩ C _T = 680 pF	-	3.5	3.8	V
	Max Duty Cycle	V _{OPM}		1.55	1.85	-	V
Output Section	"H" Level Output Voltage	V _H	I _{OUT} = -100 mA	12.5	13.5	-	V
	"L" Level Output Voltage	V _L	I _{OUT} = 100 mA	-	1.1	1.3	V
	Rise Time	t _r	C _L = 1000 pF, R _L = ∞	-	60	120	ns
	Fall Time	t _f	C _L = 1000 pF, R _L = ∞	-	30	80	ns
Over Voltage Detector	Threshold Voltage	V _{OVP}	-	2.4	2.5	2.6	V
	Input Current	I _{OVP}	V _{IN} = 0 V	-1.0	-0.2	-	μA
	V _{CC} Reset	V _{CC RST}	-	2.0	3.0	4.5	V
Under Voltage Out Stop	Off to On	V _{THH}	-	9.2	10.0	10.8	V
	On to Off	V _{THL}	-	7.2	8.0	8.8	V
Supply Current	Standby *	I _{STB}	R _T = 18 kΩ 4 pin Open	-	1.5	2.0	mA
	Operating	I _{CC}	R _T = 18 kΩ	-	8.0	12.0	mA
	Zener Voltage	V _Z	I _Z = 1 mA	-	15.4	-	V
	Zener Current	I _Z	V ₁₁₋₇ = 1 V	-	0.03	-	mA

* : V_{CC} = 8V

MB3769A

Fig. 2 - MB3769A Test Circuit

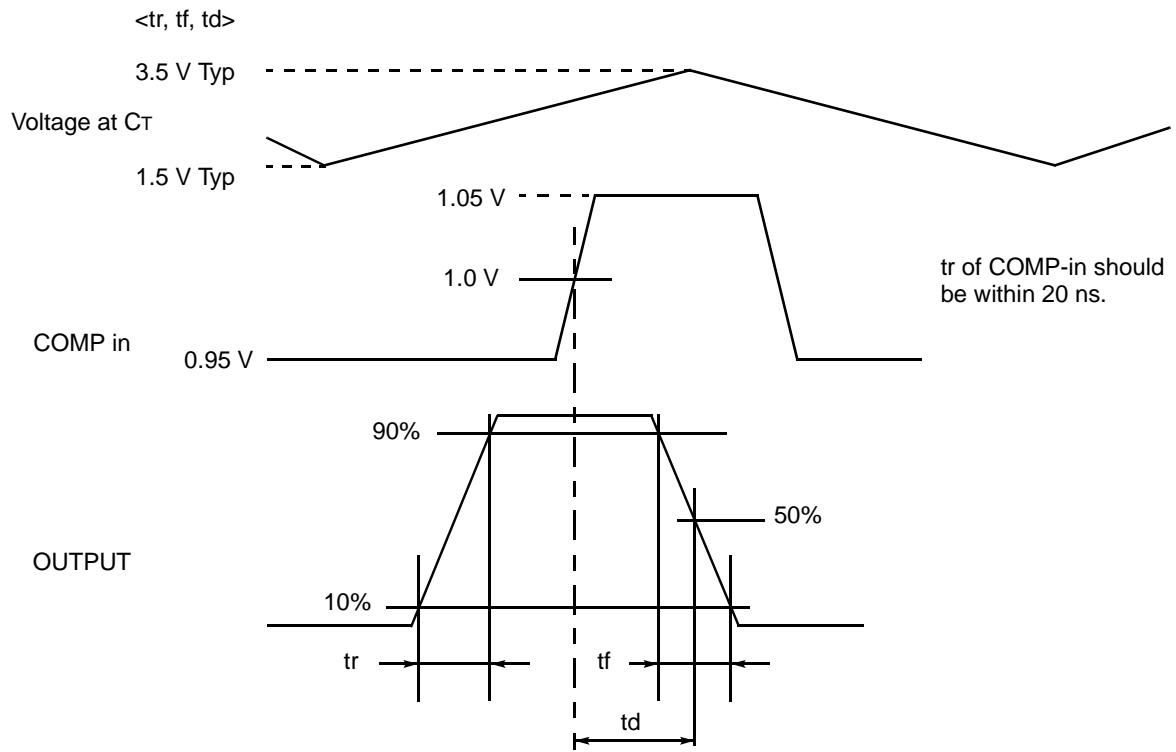
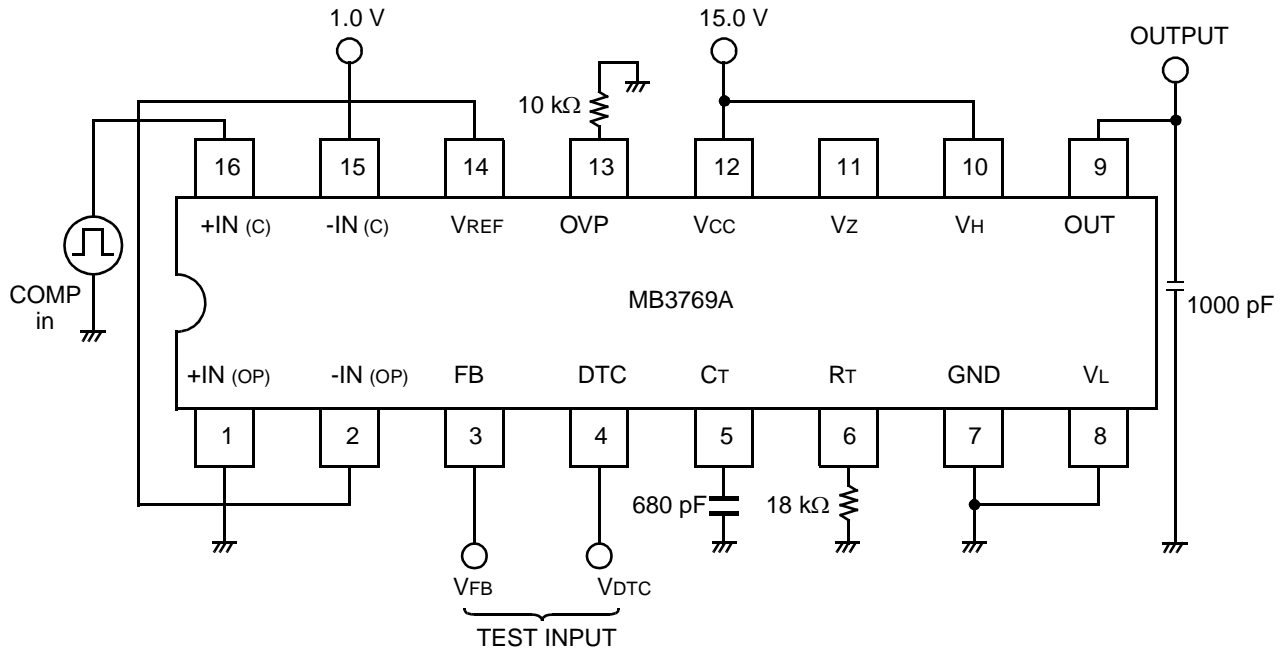

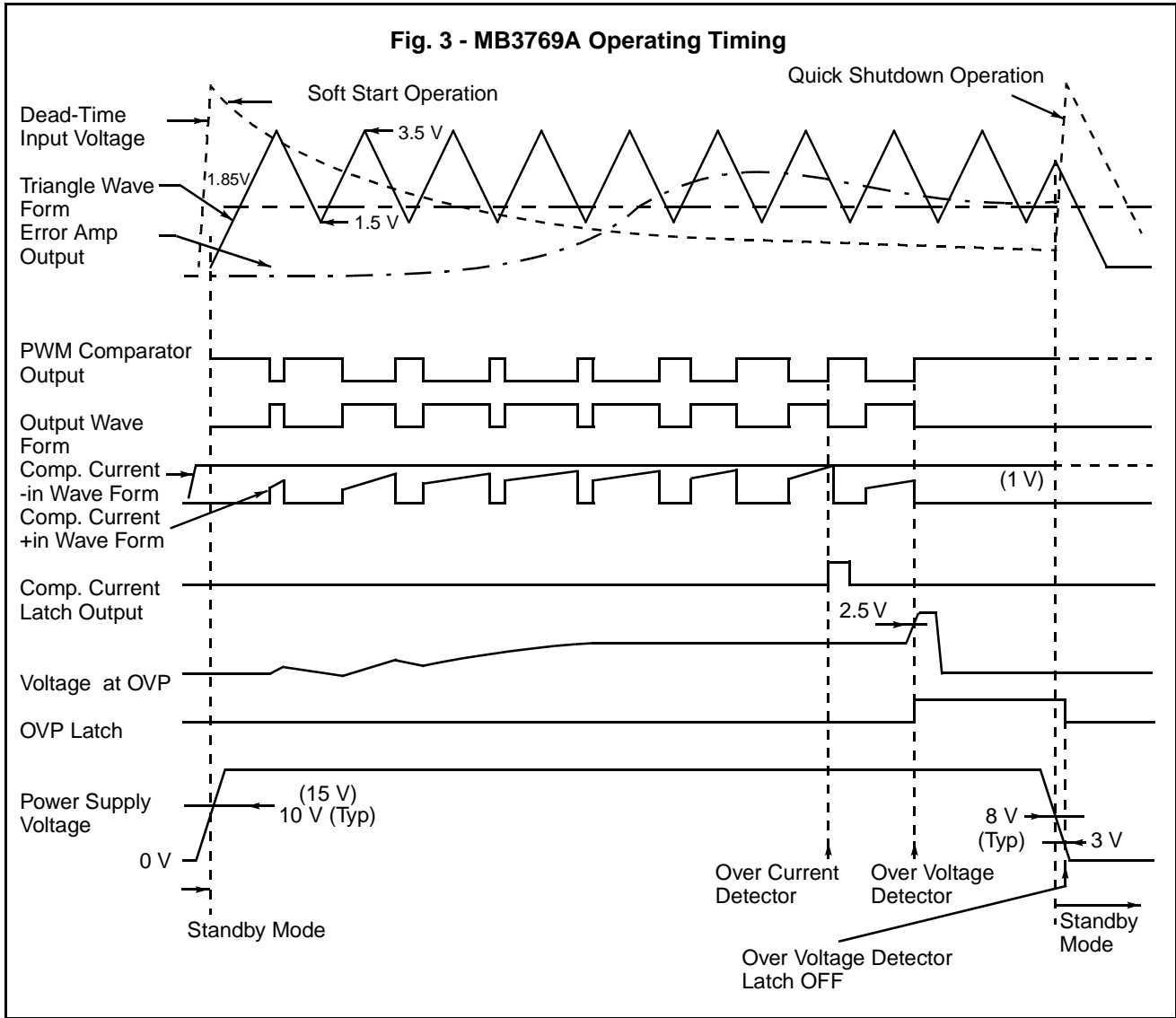

FUNCTIONS

1. Error Amplifier

The error amplifier detects the output voltage of the switching regulator.

The error amplifier uses a high-speed operational amplifier with an 8 MHz bandwidth (typical) and 6 V/ μ s slew rate (typical).

For ease of use, the common mode input voltage ranges from -0.2 V to $V_{CC}-3$ V. Figure 4 shows the equivalent circuit.

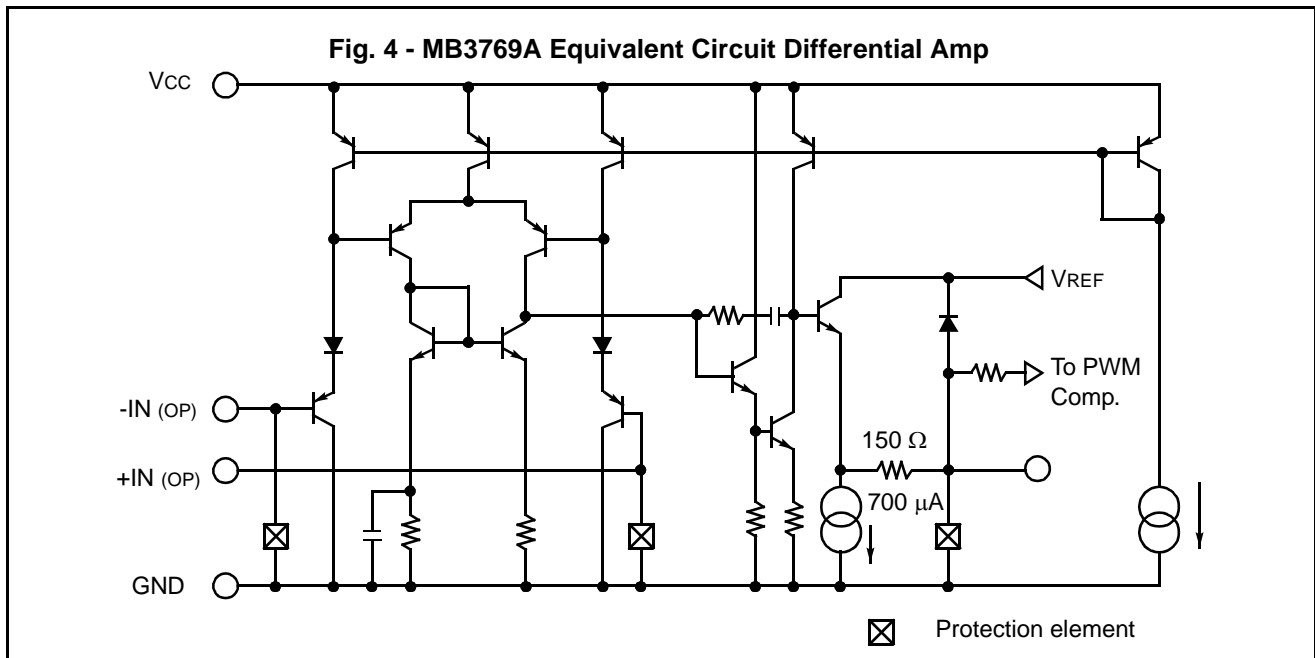

2. Overcurrent Detection Comparator

There are two methods for protection of the output transistor of this device from overcurrents; one restricts the transistor's on-time if an overcurrent that flows through the output transistor is detected from an average output current, and the other detects an overcurrent in the external transistor (FET) and shuts the output down instantaneously. Using average output currents, the peak current of the external transistor (FET) cannot be detected, so an output transistor with a large safe operation area (SOA) margin is required.

For the method of detecting overcurrents in the external transistor (FET), the output transistor can be protected against a shorted filter capacitor or power-on surge current.

The MB3769A uses dynamic current limiting to detect overcurrents in the output transistor (FET). A high-speed comparator and flip-flop are built-in.

To detect overcurrents, compare the voltage at +IN(C) of current detection resistor connected the source of the output transistor (FET), with the reference voltage (connected to -IN(C)) using a comparator. To prevent output oscillation during overcurrent, flip-flop circuit protects against double pulses occurring within a cycle.

The output of overcurrent detector is ORed with other signals at the PWM comparator. See the example "Application Example" for details on use.

Figure 5 shows the equivalent circuit of the over-current detection comparator.

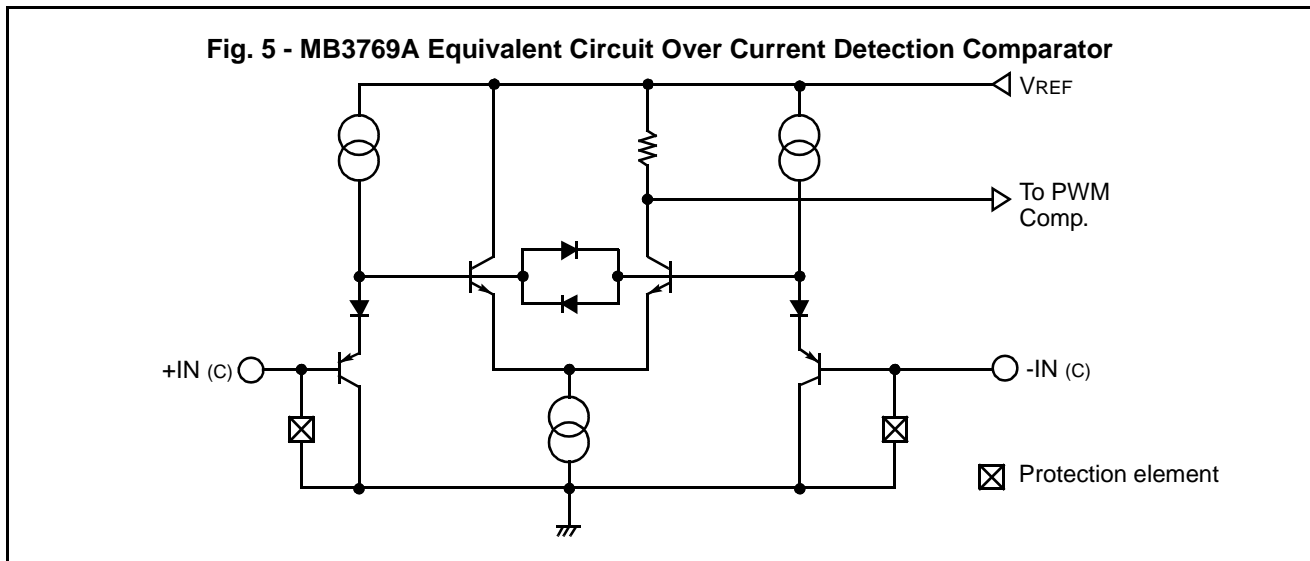

3. DTC: Dead Time Control (Soft-Start and Quick Shutdown)

The dead time control terminal and the error amplifier output are connected to the PWM comparator.

The maximum duty cycle for V_{DTC} (voltage applied to pin 4) is obtained from the following formula (approximate value at low frequency):

$$\text{Duty Cycle} = (3.5 - V_{DTC}) \times 50 (\%) \quad [0\% \leq \text{duty cycle} \leq D_{MAX} (80\%)]$$

The dead time control terminal is used to provide soft start.

In Figure 6, the DTC terminal is connected to the V_{REF} terminal through R and C. Because capacitor C does not charge instantaneously when the power is turned on, the output transistor is kept turned off. The DTC input voltage and the output pulse width increase gradually according to the RC time constant so that the control system operates safely.

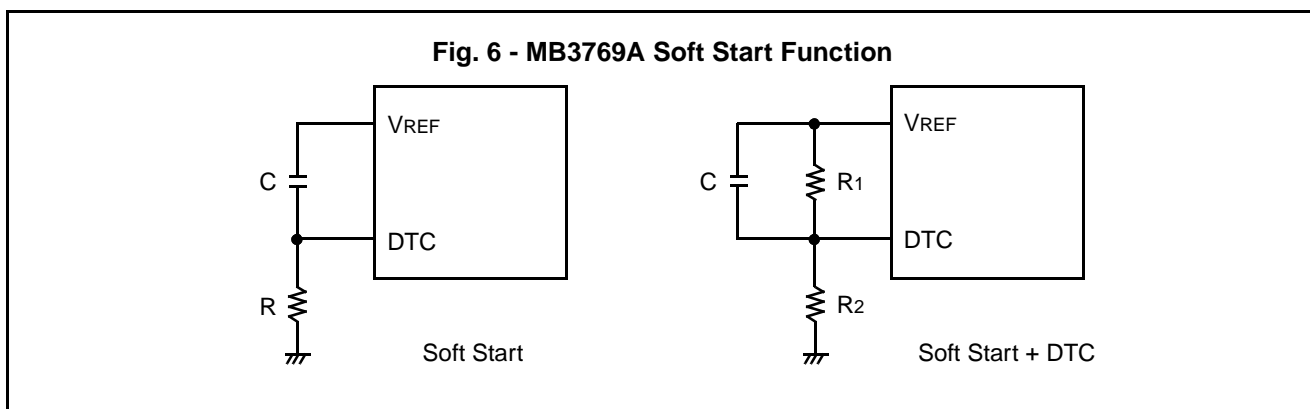

The quick shutdown function prevents soft start malfunction when the power is turned off and on quickly. After the power is shut down, soft start is disabled because the DTC terminal has low electric potential from the beginning if the power is turned on again before the capacitor is discharged. The MB3769A prevents this by turning on the discharge transistor to quickly discharge the capacitor in the stand-by mode.

4. Triangular Wave Oscillator

The oscillation frequency is expressed by the following formula:

$$f_{osc} \approx \frac{1}{0.8 \times C_T \times R_T + 0.0002 \text{ ms}} \text{ [kHz]} \quad \begin{array}{l} C_T : \mu\text{F} \\ R_T : \text{k}\Omega \end{array}$$

For master/slave synchronized operation of several MB3769As, the C_T and R_T terminals of the master MB3769A are connected in the usual way and the C_T terminals of the master and slave device (s) are connected together. The slave MB3769A's R_T terminal is connected to its V_{REF} terminal to disable the slave's oscillator. In this case, set $50/n \text{ k}\Omega$ (n is the number of master and slave ICs) to the upper limit of R_T so that internal bias currents do not stop the master oscillation.

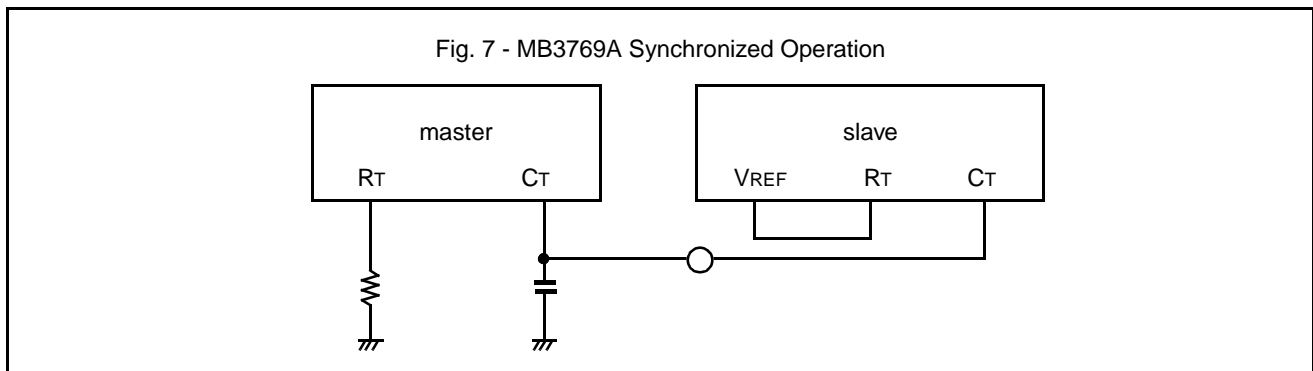

5. Overvoltage Detector

The overvoltage detection circuit shuts the system power down if the switching regulator's output voltage is abnormal or if abnormal voltage is appeared. The reference voltage is 2.5 V ($V_{REF} / 2$). The system power is shut down if the voltage at pin 13 rises above 2.5 V. The output is kept shut down by the latching circuit until the power supply is turned off (see Figure 3).

6. Stand-by Mode and Under-Voltage Lockout (UVLO)

Generally, $V_{GS} > 6$ to 8 V is required to use power MOSFET for switching. UVLO is set so that output is on at $V_{CC} \geq 10$ V (standard) when the power is turned on and is off at $V_{CC} \leq 8$ V (standard) when the power is turned off.

In the stand-by mode, the power supply current is limited to 2 mA or less when the output is inhibited by the UVLO circuit. When the MB3769A is operated from the 100 VAC line, the power supply current is supplied through resistor R (Figure 8). That is, the IC power supply current is supplied by the AC line through resistor R until operation starts. Current is then supplied from the transformer tertiary winding, eliminating the need for a second power supply.

Two volts (typical) of hysteresis are provided for return from operation mode to stand-by mode not to return to stand-by mode until output power is turned on or to avoid malfunction due to noise.

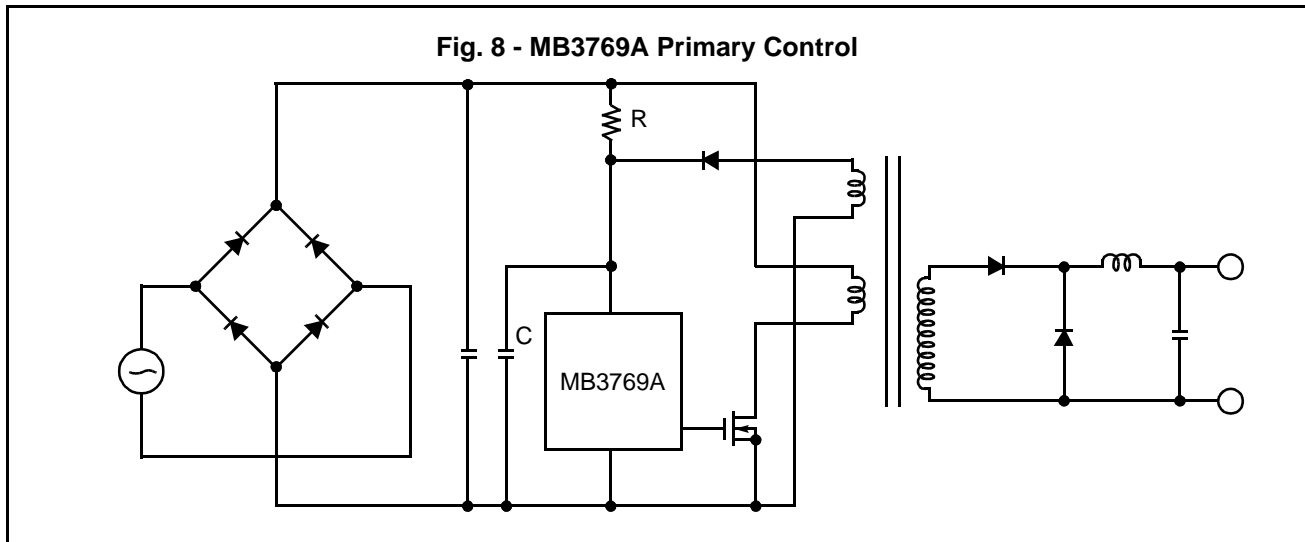

7. Output Section

Because the OUT terminal (pin 9) carries a large current, the collector and emitter of the output transistor are brought out to the VH and VL terminals. In principle, VH is connected to VCC and VL is connected to GND, but VH can be supplied from another power supply (4 V to 18 V). Note that VL and GND should be connected as close to the IC package as possible. A capacitor of 0.1 μF or more is inserted between VH and VL (see Figure 9).

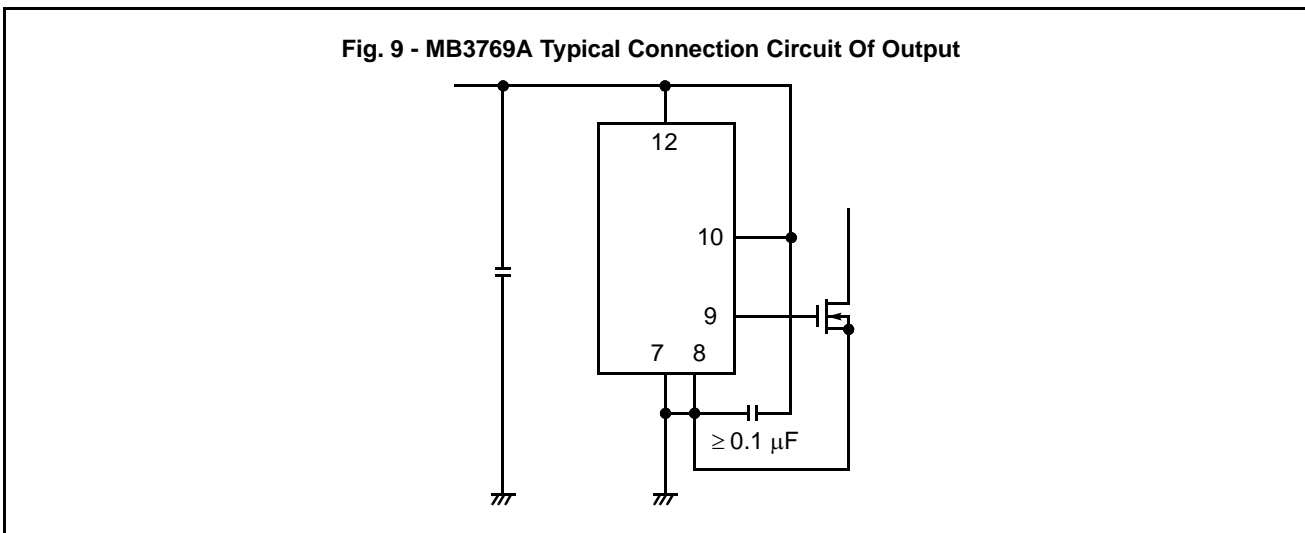

■ APPLICATION EXAMPLE

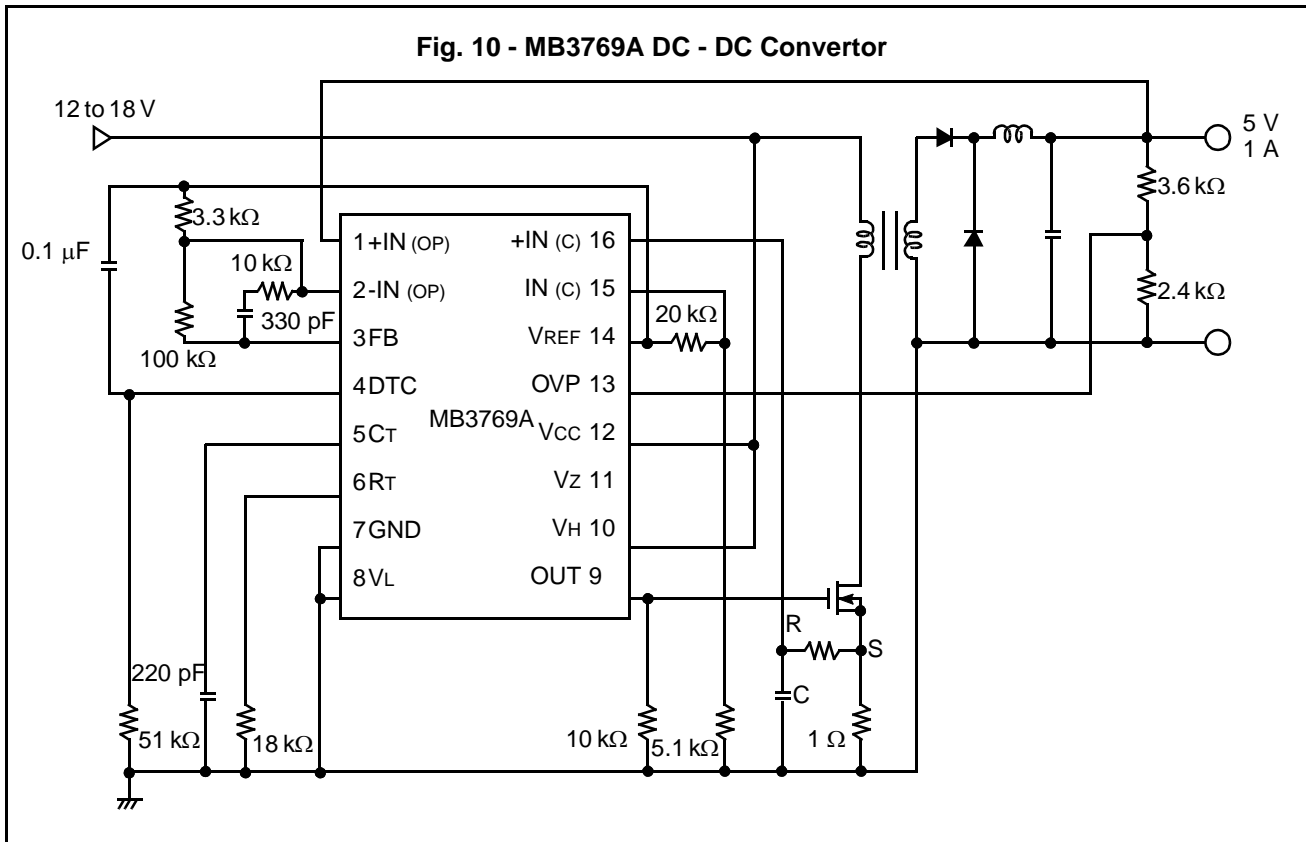

Overcurrent Protection Circuit

The waveform at the output FET source terminal is shown in Figure 11. The RC time constant must be chosen so that the voltage glitch in the waveform does not cause erroneous overcurrent detection. This time constant should be from 5 ns to 100 ns. A detection current value depends on R or C because a waveform is weakened. To keep this glitch as small as possible, the rectifiers on the transformer secondary winding must be the fast-recovery type.

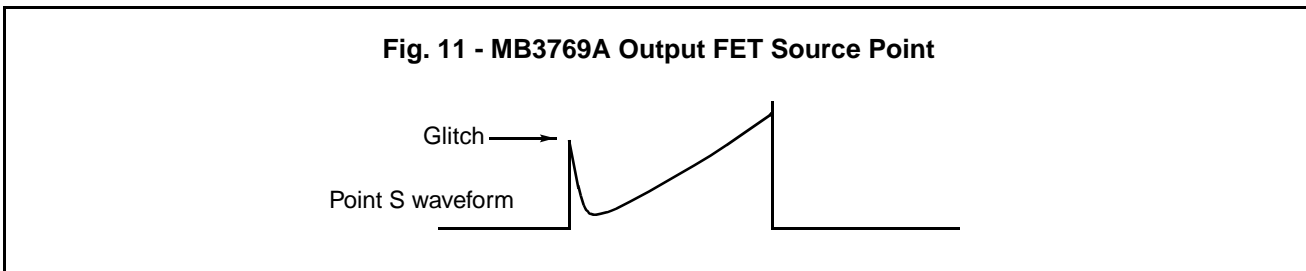

Fig. 12 -Primary Control

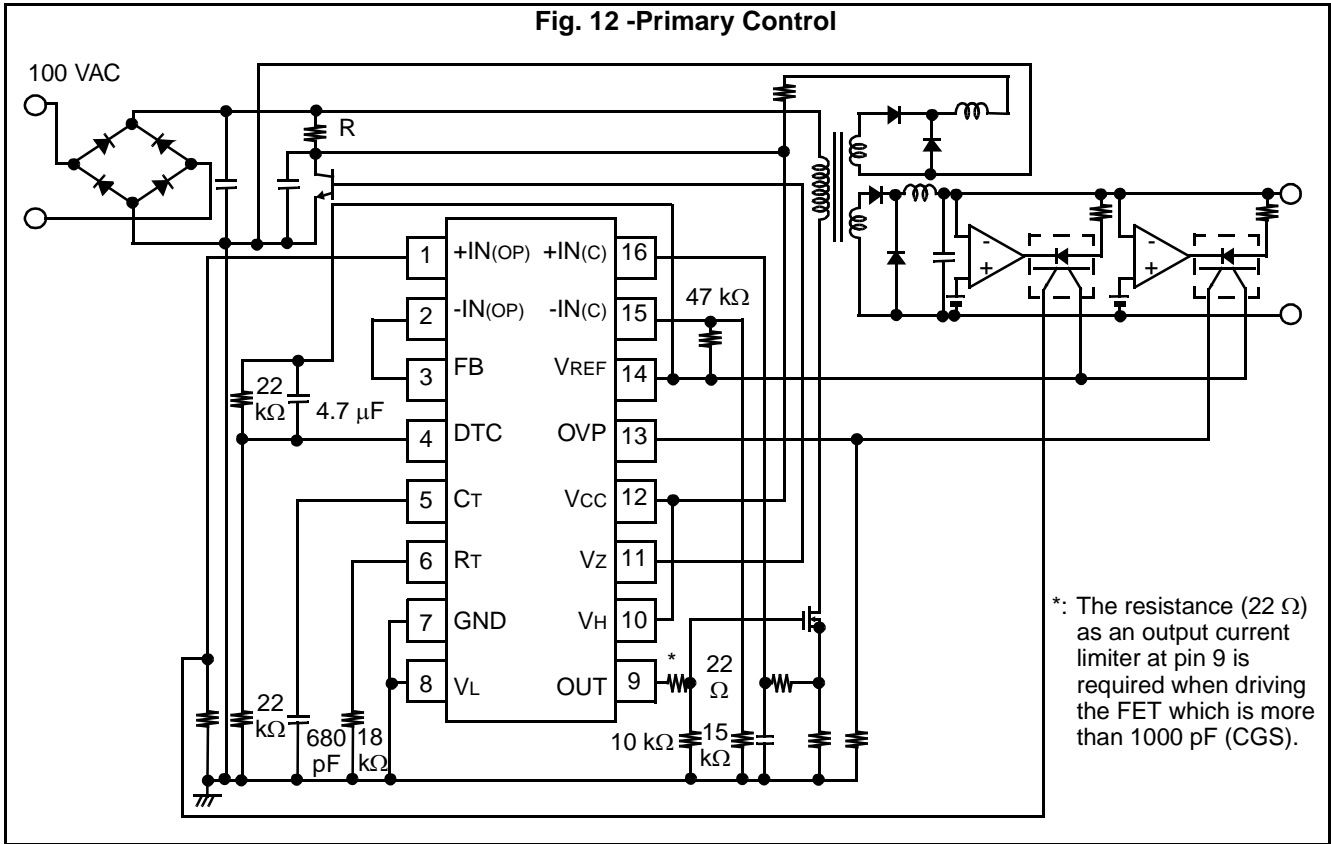
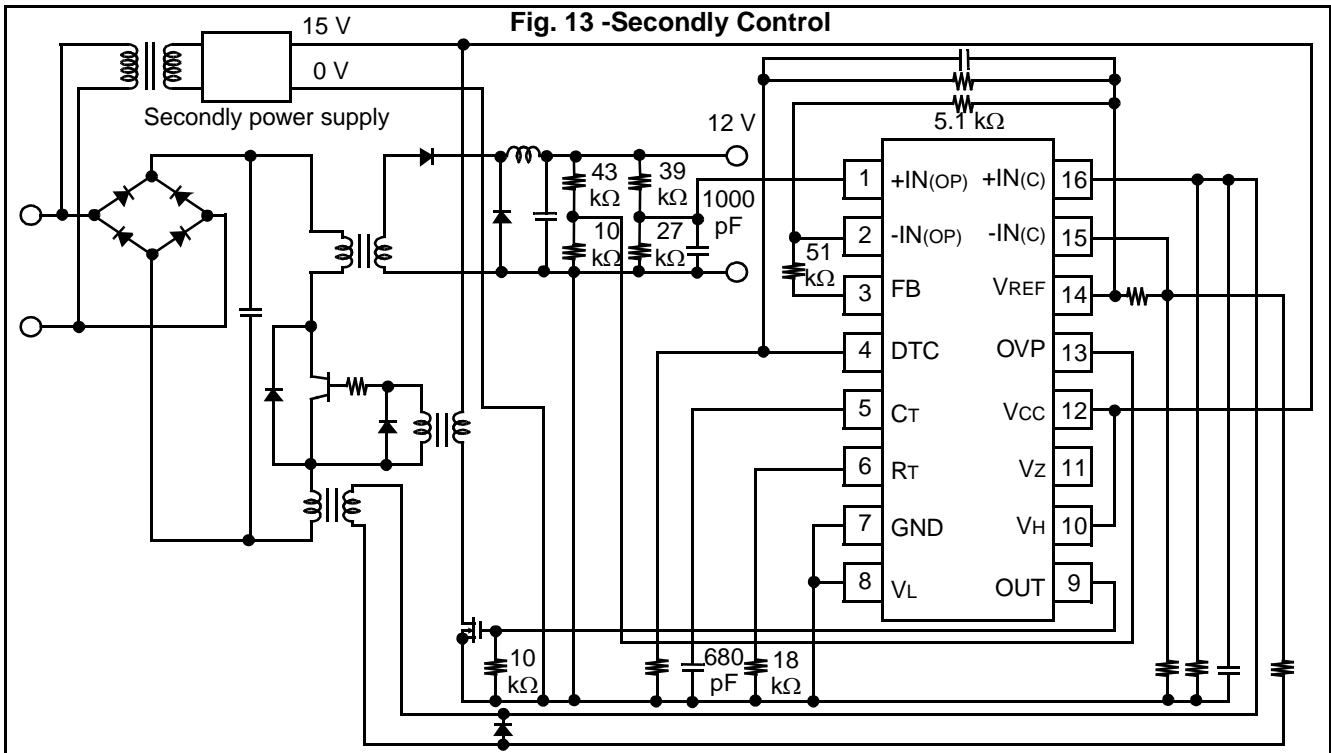
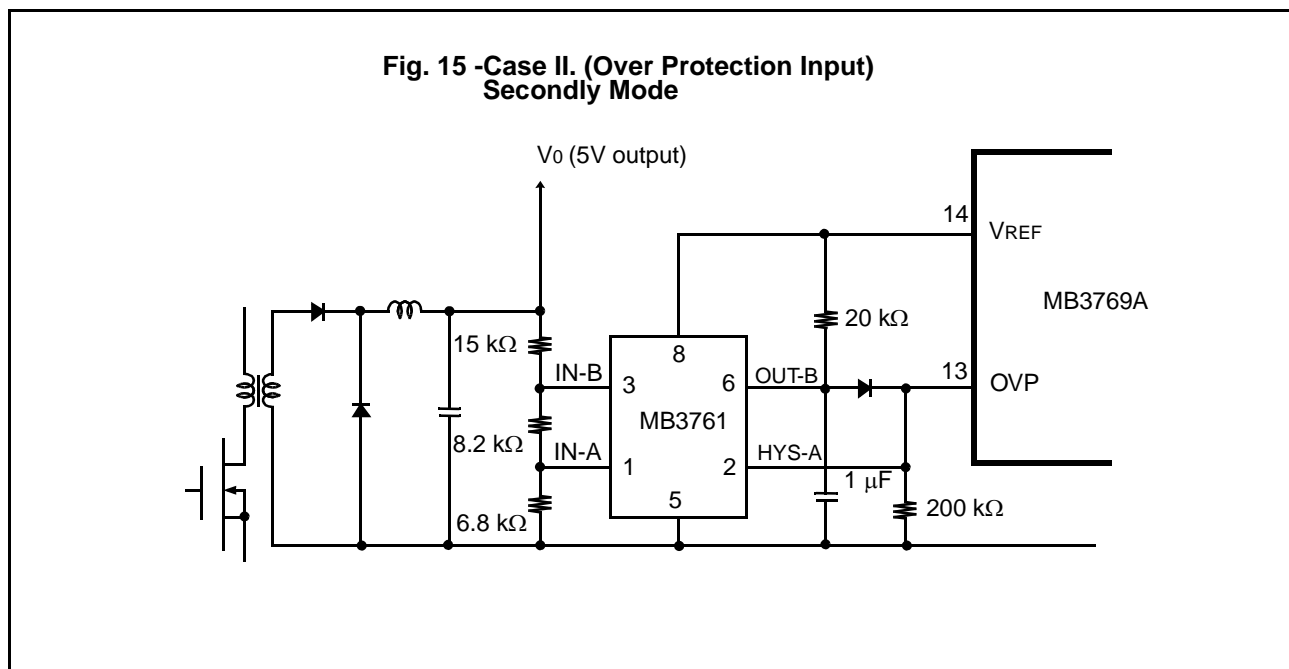
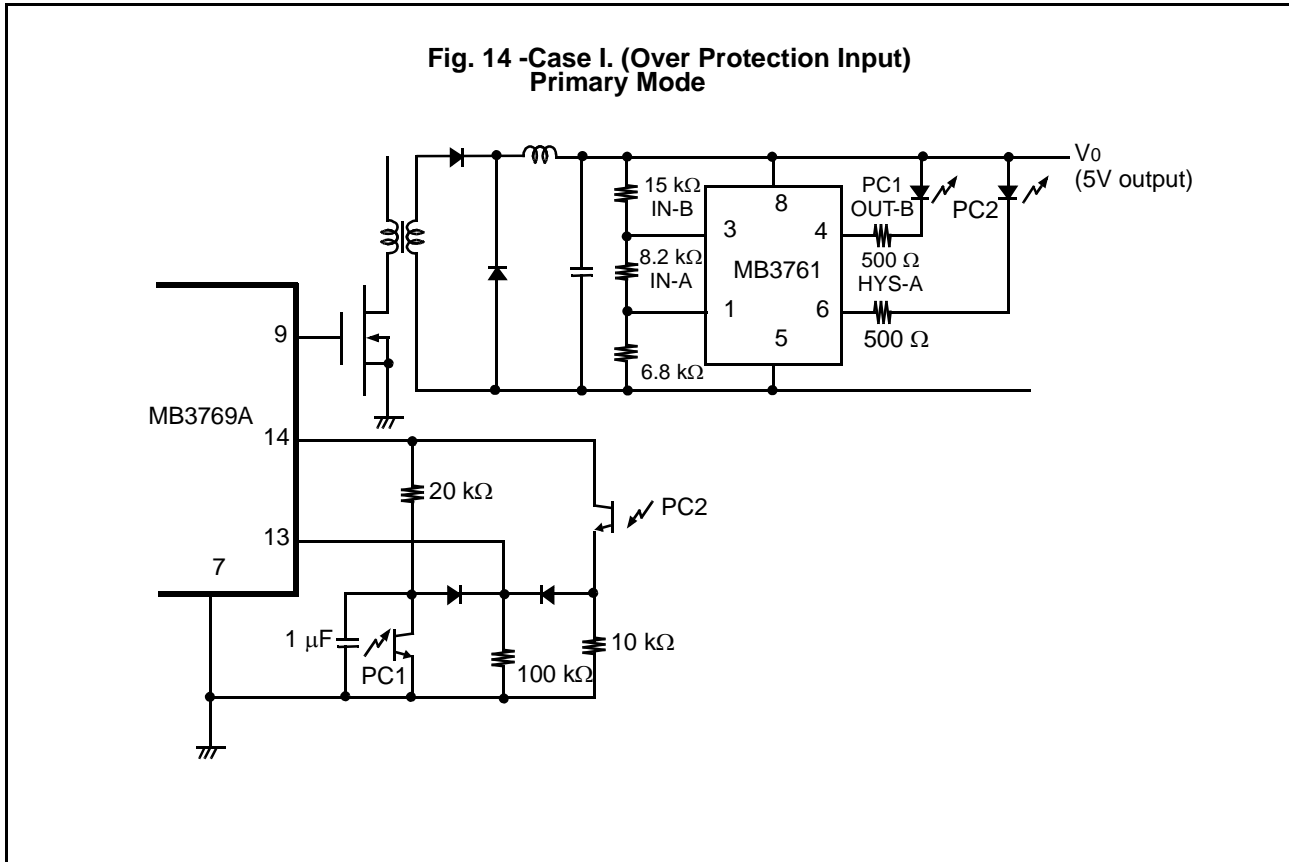

Fig. 13 -Secondly Control



■ SHORT PROTECTION CIRCUIT

The system power can be shut down to protect the output against intermittent short-circuits or continuous overloads. This protection circuit can be configured using the OVP input as shown in Figure 14.



■ HOW TO SYNCHRONIZE WITH OUTSIDE CLOCK

The MB3769A oscillator circuit is shown in Figure 16. C_T charge and discharge currents are expressed by the following formula:

$$I_{CT} = \pm 2 \times I_1 = \pm \frac{5V}{R_T}$$

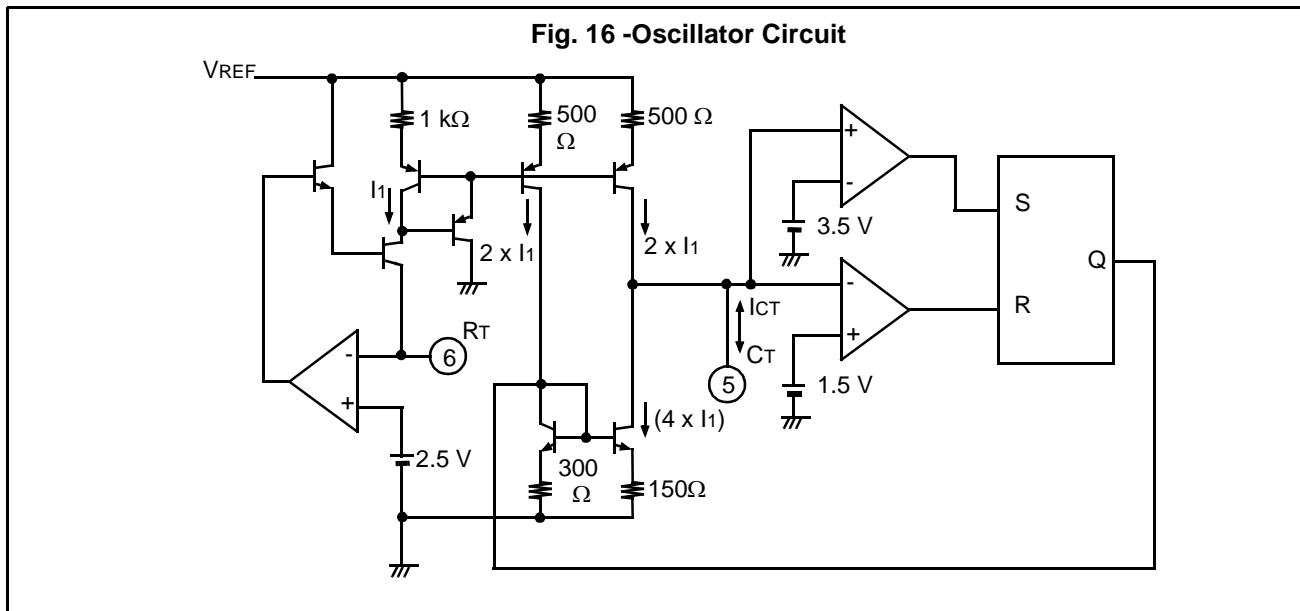

This circuit shows that if the voltage at the C_T terminal is set to 1.5 V or less, one oscillation cycle ends and the next cycle starts. An example of an external synchronous clock circuit is shown in Figure 17.

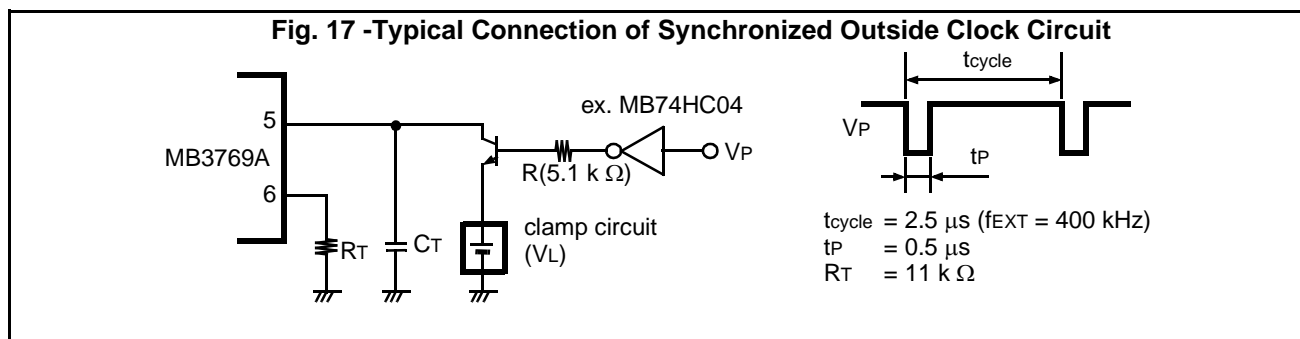

The Figure 18 shows the C_T terminal waveform.

V_{TH} may be near 2.5 V. In this case, the maximum duty cycle is restricted as shown in the formula below if $t_{P'} = 0$.

$$D_{max} = \frac{(3.5 - 1.85) + (3.5 - V_{TH})}{(3.5 - V_L) + (3.5 - V_{TH})} \leq 59\% \quad (V_L = 0V: \text{No clamp circuit})$$

When $V_{TH} = 2.5V$, C_T can be provided by followings.

$$t_{cycle} - t_P = \frac{1}{f_{osc}} \times \frac{(3.5 - V_L) + (3.5 - V_{TH})}{f_{osc}(3.5 - 1.5) \times 2}$$

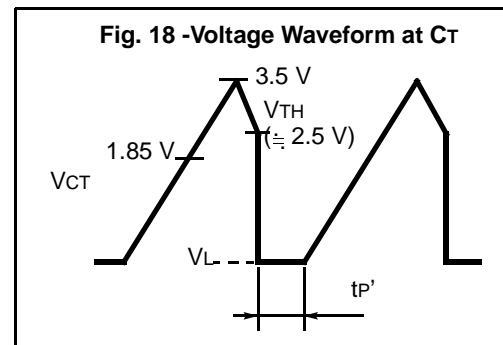

MB3769A

$$f_{OSC} \approx \frac{1}{0.8 \times C_T \times R_T}$$

$$C_T \approx \frac{1}{0.8 \times R_T} \times \frac{4}{4.5 - V_L} \quad (t_{cycle} - t_P) \text{ [pF]} \quad (R_T: \text{k}\Omega, t_{cycle}, t_P: \text{ns})$$

Make V_L high for a large duty cycle for the clamp circuit. The circuits below can be used because the clamp voltage must be much lower than 1.5 V.

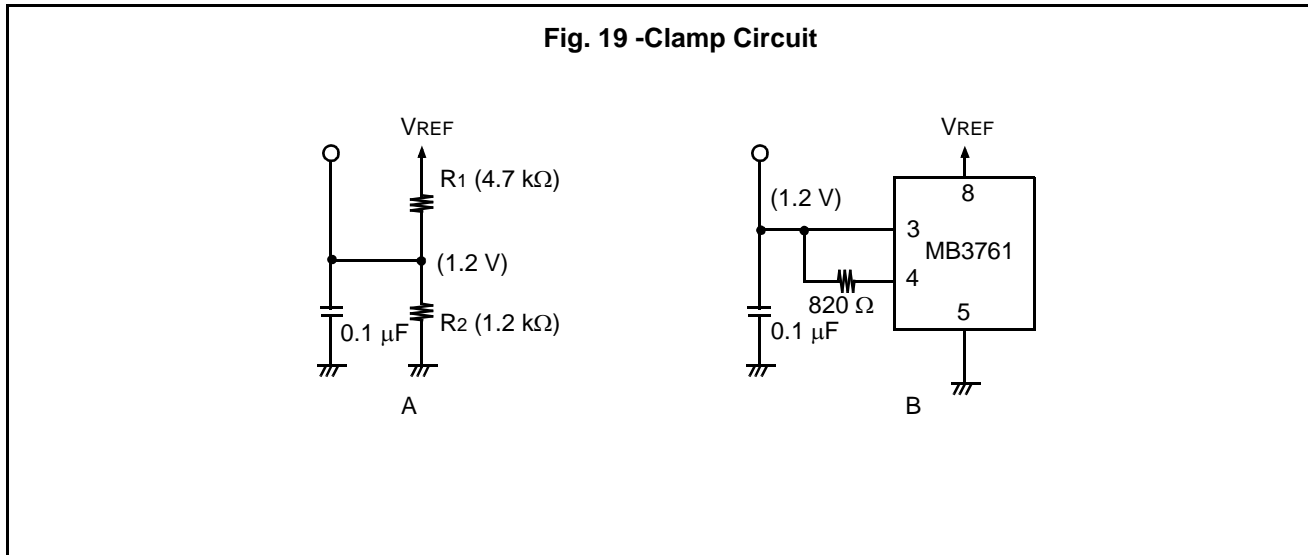

In circuit A, R_1 and R_2 must be determined considering the effects of t_P , R , or R_T .

The transistor saturation voltage must be very small (<0.15 V) for any clamp circuit, so a transistor with a very small $V_{CE(sat)}$ should be used.

■ SYNCHRONIZED OUTSIDE CLOCK CIRCUIT

Fig. 20

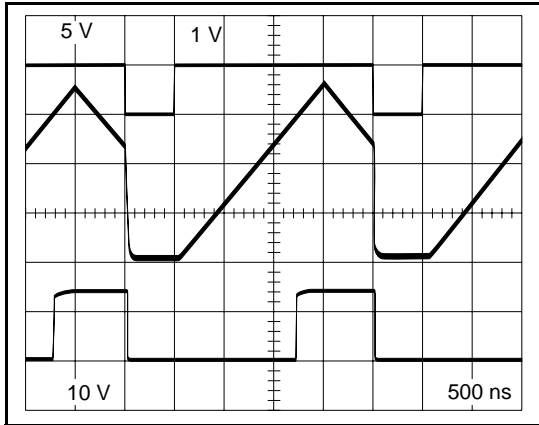

VP (5 V/div)

CT (1 V/div)

GND Level (CT)

OUT (10 V/div)

1.No Clamp Circuit (Connect with GND)

$C_T = 150 \text{ pF} + \text{Probe Capacitor} (\approx 15 \text{ pF})$
 $R_T = 11 \text{ k}\Omega$

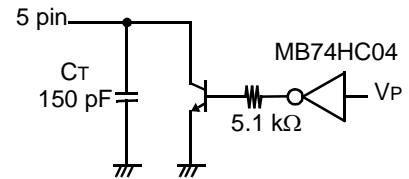
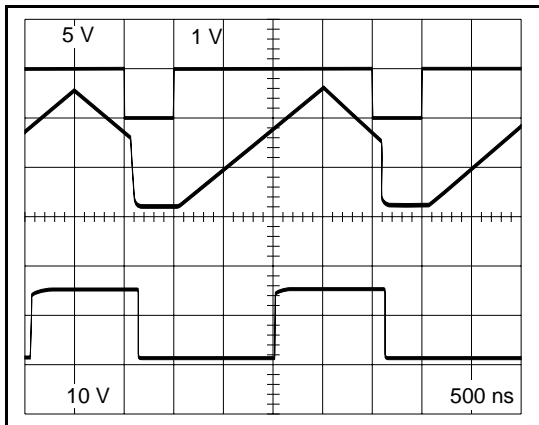

Fig. 21



VP (5 V/div)

CT (1 V/div)

GND Level (CT)

OUT (10 V/div)

2.Clamp Circuit A (Dividing Resistor)

$C_T = 220 \text{ pF} + \text{Probe capacitor} (\approx 15 \text{ pF})$
 $R_T = 11 \text{ k}\Omega$

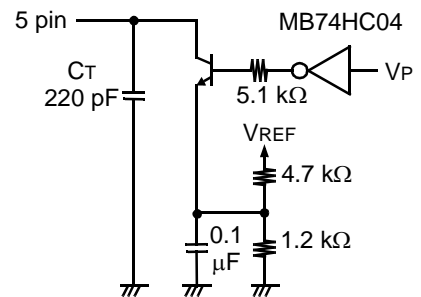
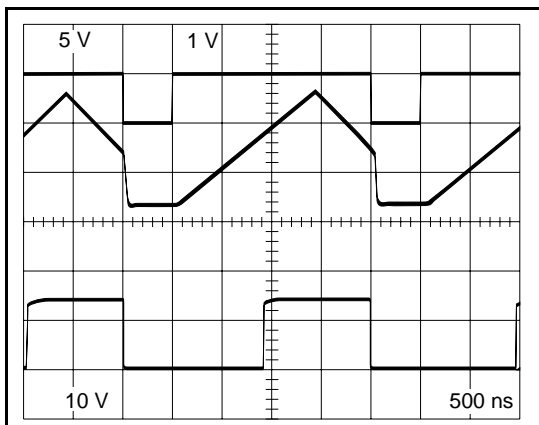

Fig. 22



VP (5 V/div)

CT (1 V/div)

GND Level (CT)

OUT (10 V/div)

3.Clamp Circuit B (Apply MB3761)

$C_T = 220 \text{ pF} + \text{Probe capacitor} (\approx 15 \text{ pF})$
 $R_T = 11 \text{ k}\Omega$

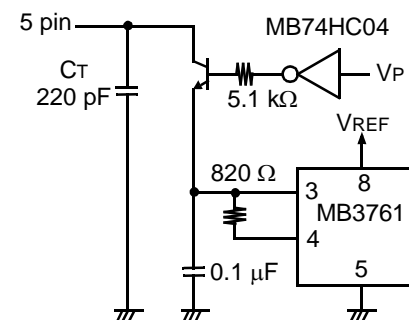

MB3769A

Fig. 23 -Test Circuit

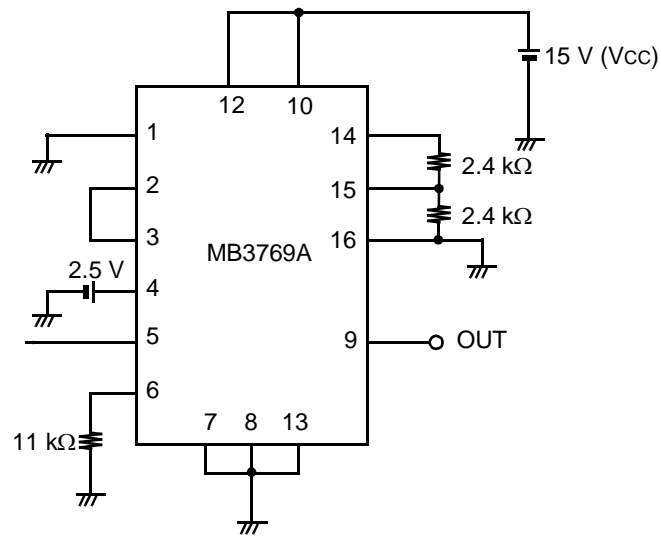

TYPICAL PERFORMANCE CHARACTERISTICS

Fig. 24 -Power Supply Voltage vs. Power Supply Current (Low Voltage stop of V_{CC})

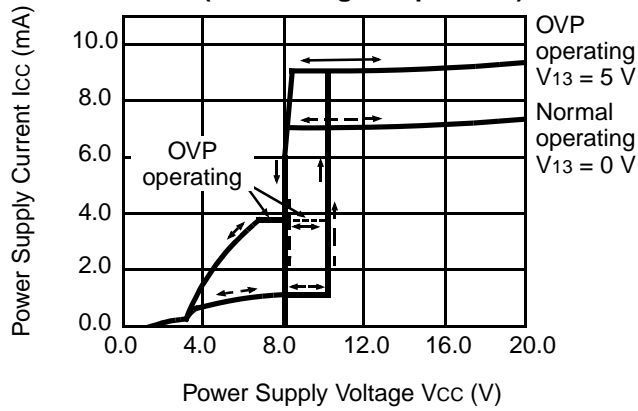

Fig. 25 -Standby Current vs. Operating Ambient Temperature

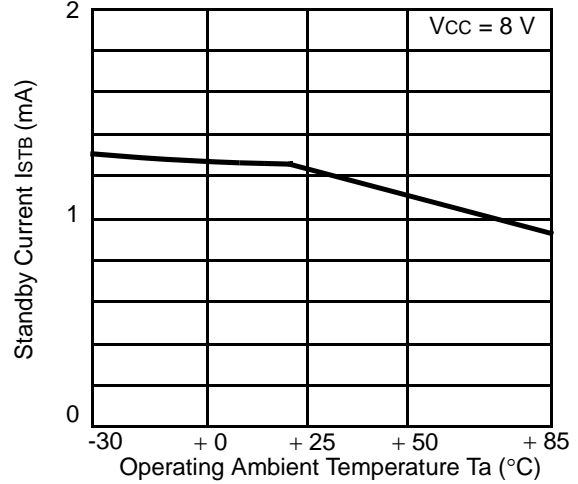

Fig. 26 -Reference Voltage

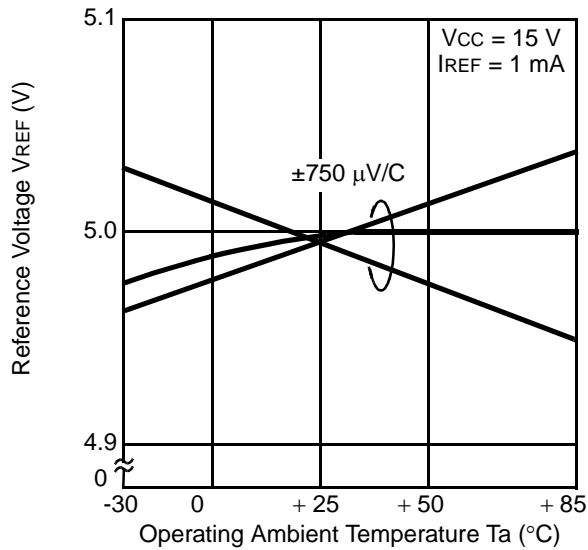

Fig. 27 -"L" level Output Voltage vs. "L" level Output Current

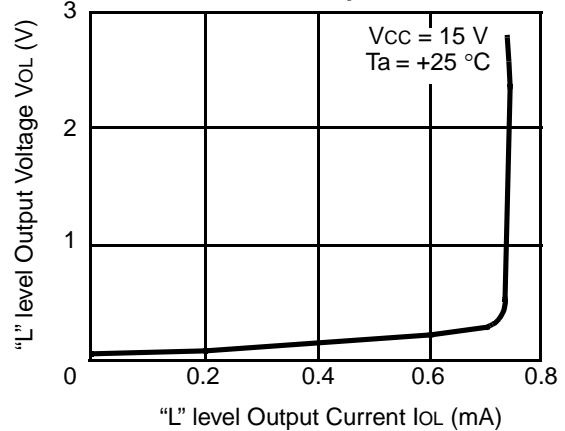
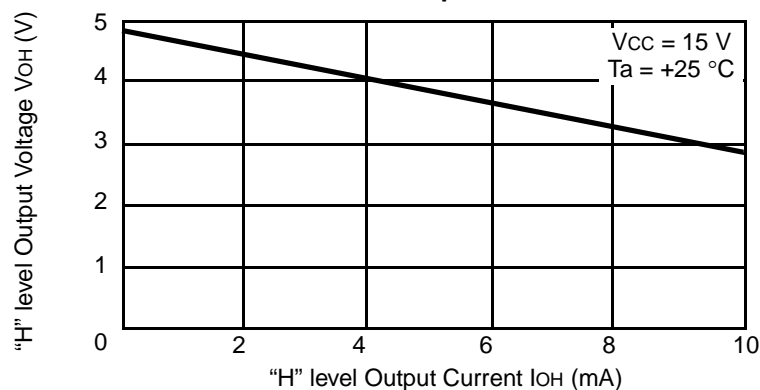

Fig. 28 -"H" level Output Voltage vs. "H" level Output Current



(Continued)

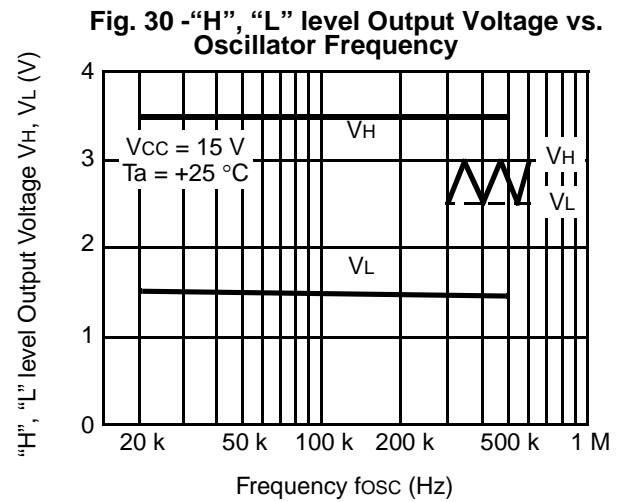
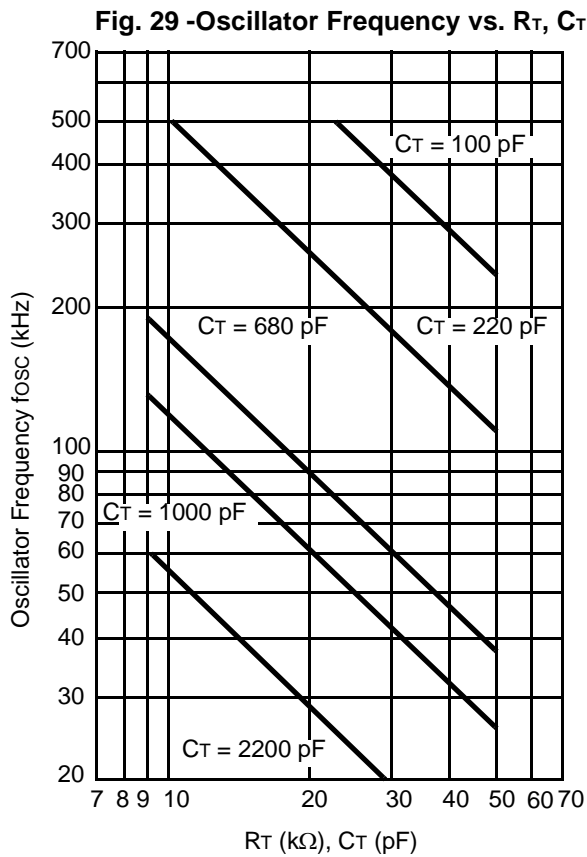

Fig. 31 -Duty Cycle vs. Dead Time Control Voltage

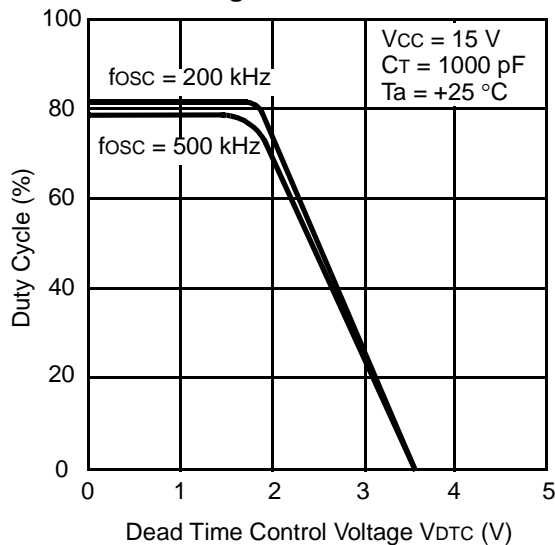

Fig. 32 -Oscillator Frequency vs. Operating Ambient Temperature

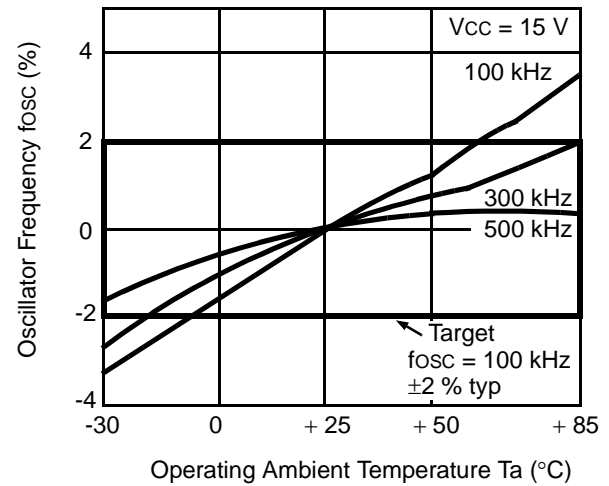
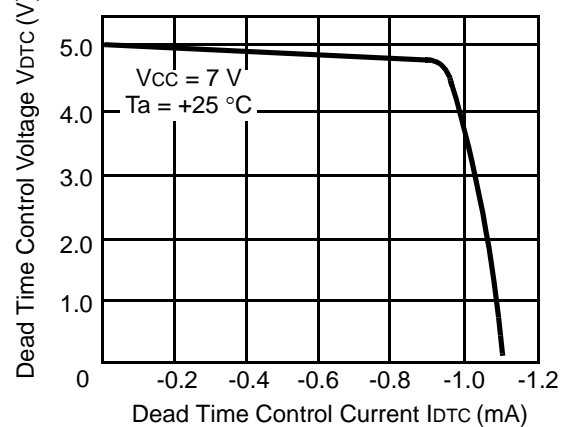
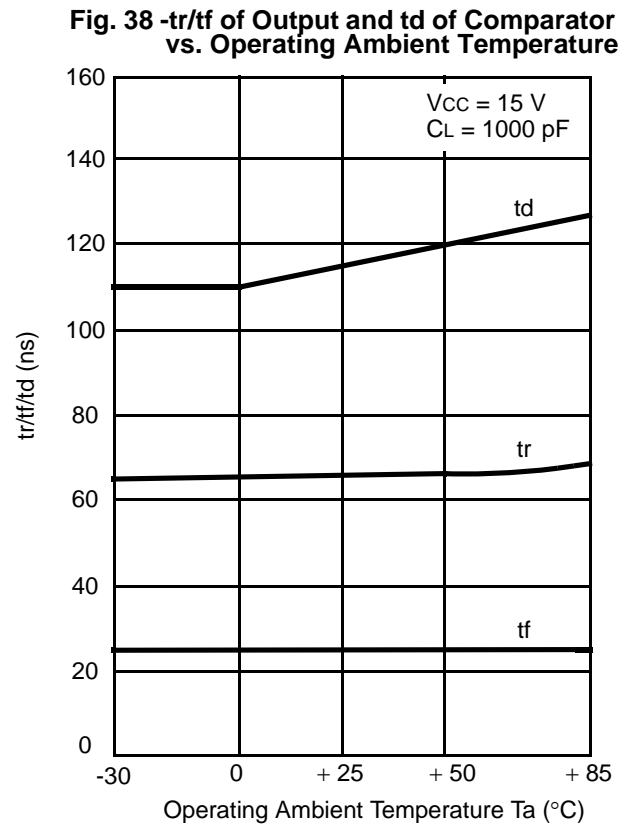
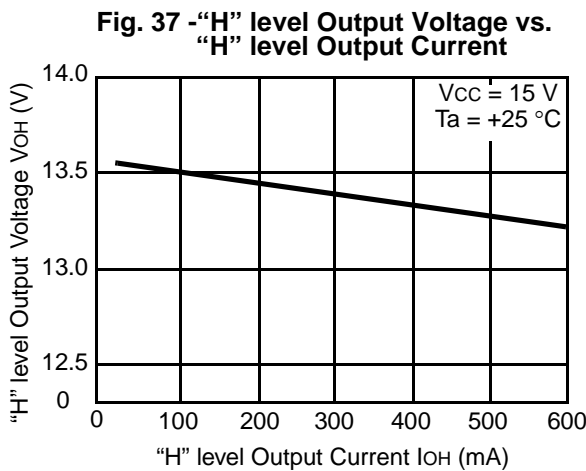
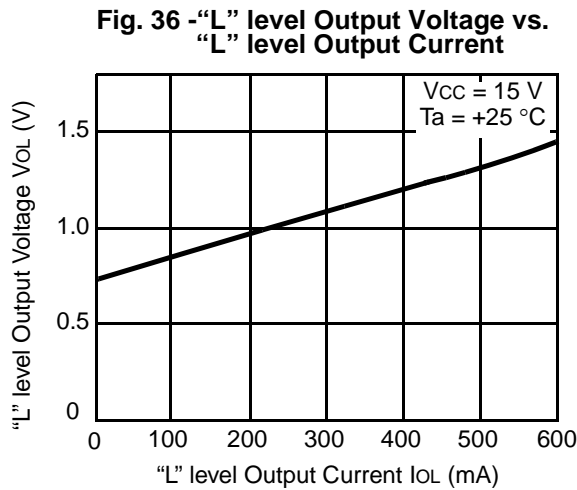
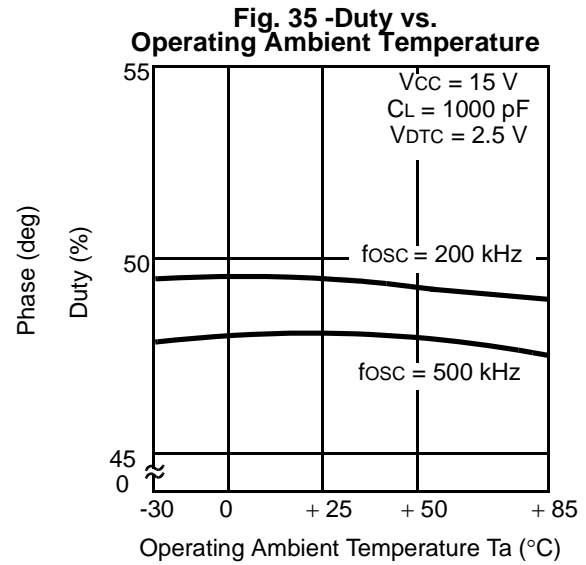
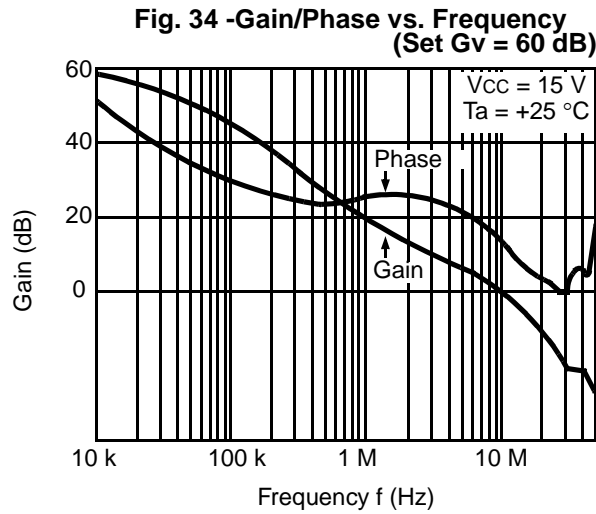

Fig. 33 -Dead Time Control Voltage vs. Current(Standby Mode)



(Continued)



(Continued)

(Continued)

Fig. 39 -OVP Latch Standby Power Supply Current vs. Operating Ambient Temperature

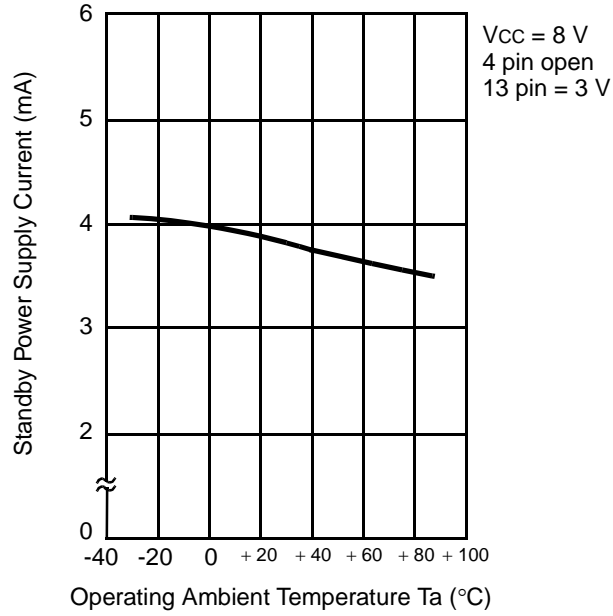
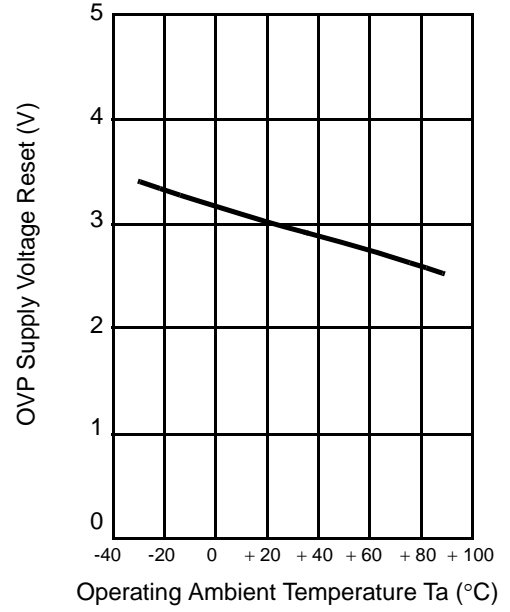

Fig. 40 -OVP Supply Voltage Reset vs. Operating Ambient Temperature



■ NOTES ON USE

- Take account of common impedance when designing the earth line on a printed wiring board.
- Take measures against static electricity.
 - For semiconductors, use antistatic or conductive containers.
 - When storing or carrying a printed circuit board after chip mounting, put it in a conductive bag or container.
 - The work table, tools and measuring instruments must be grounded.
 - The worker must put on a grounding device containing 250 kΩ to 1 MΩ resistors in series.
- Do not apply a negative voltage
 - Applying a negative voltage of -0.3 V or less to an LSI may generate a parasitic transistor, resulting in malfunction.

■ ORDERING INFORMATION

Part number	Package	Remarks
MB3769APF-□□□	16-pin plastic SOP (FPT-16P-M06)	Conventional version
MB3769APF-□□□E1	16-pin plastic SOP (FPT-16P-M06)	Lead Free version

■ RoHS Compliance Information of Lead (Pb) Free version

The LSI products of Fujitsu Microelectronics with “E1” are compliant with RoHS Directive , and has observed the standard of lead, cadmium, mercury, Hexavalent chromium, polybrominated biphenyls (PBB) , and polybrominated diphenyl ethers (PBDE) .

The product that conforms to this standard is added “E1” at the end of the part number.

■ MARKING FORMAT (Lead Free version)

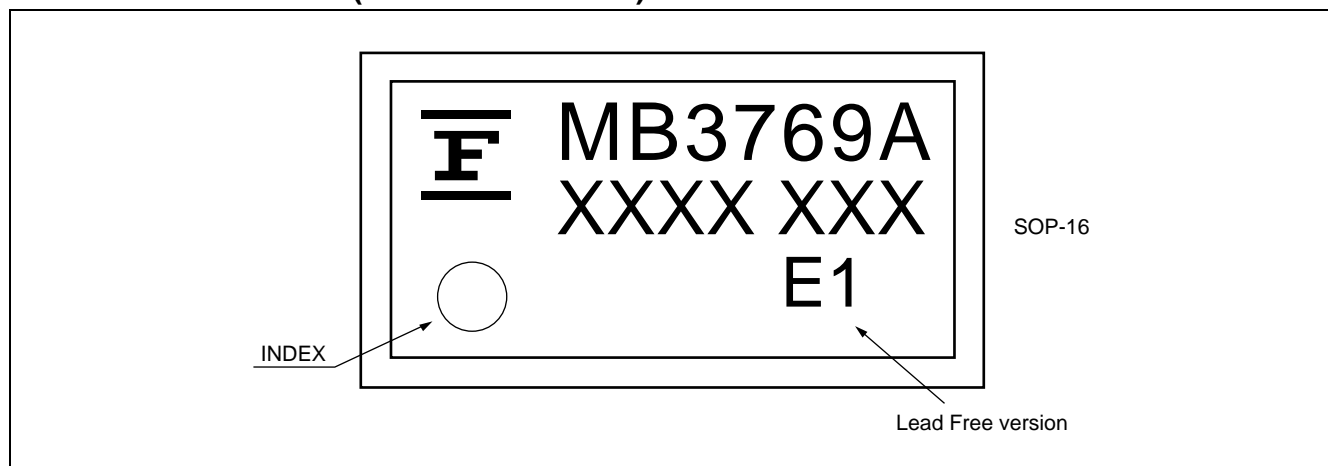

MB3769A

■ LABELING SAMPLE (Lead free version)

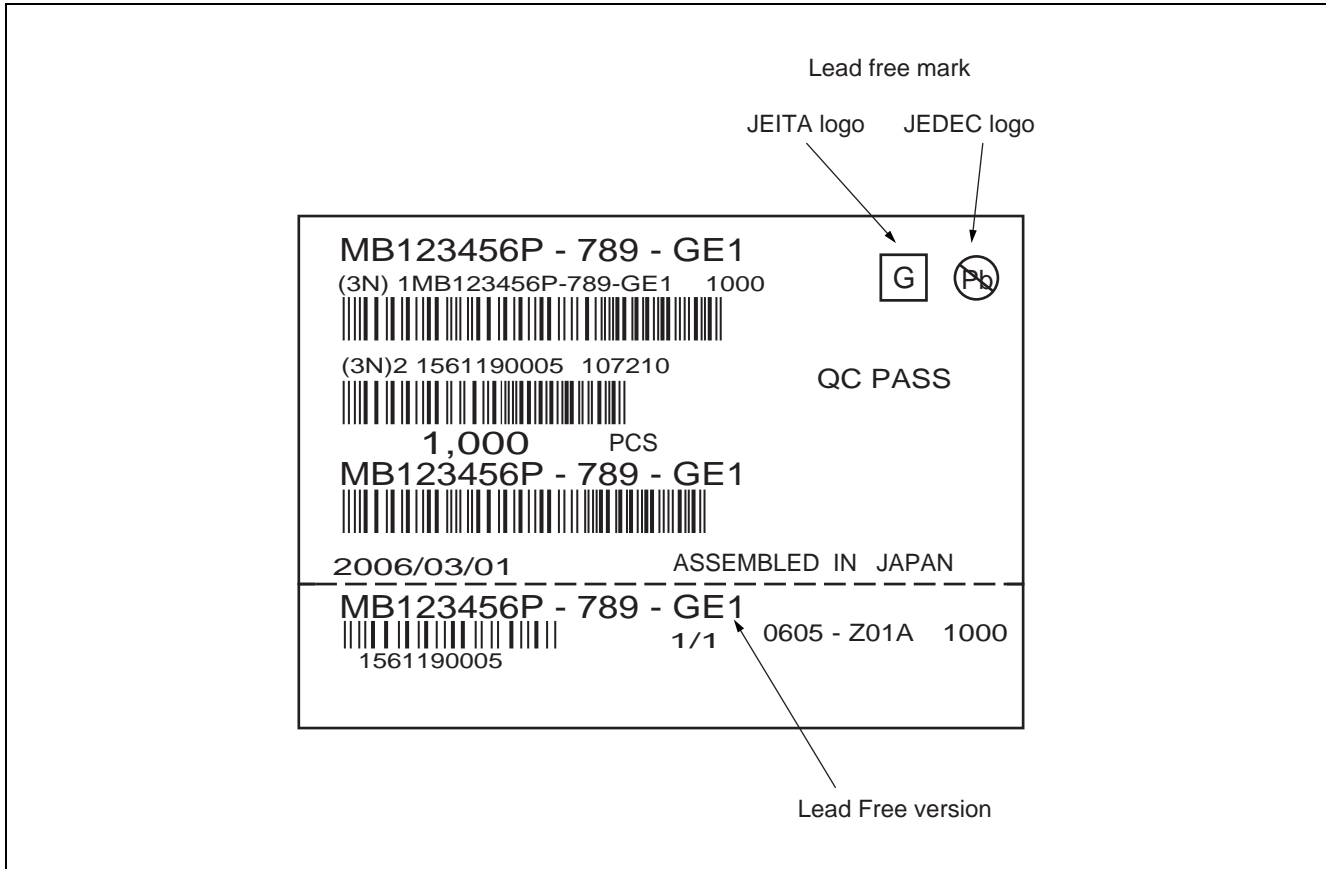

■ MB3769APF-□□□E1 RECOMMENDED CONDITIONS OF MOISTURE SENSITIVITY LEVEL

Item	Condition	
Mounting Method	IR (infrared reflow) , Manual soldering (partial heating method)	
Mounting times	2 times	
Storage period	Before opening	Please use it within two years after Manufacture.
	From opening to the 2nd reflow	Less than 8 days
	When the storage period after opening was exceeded	Please processes within 8 days after baking (125 °C, 24H)
Storage conditions	5 °C to 30 °C, 70%RH or less (the lowest possible humidity)	

[Temperature Profile for FJ Standard IR Reflow]

(1) IR (infrared reflow)

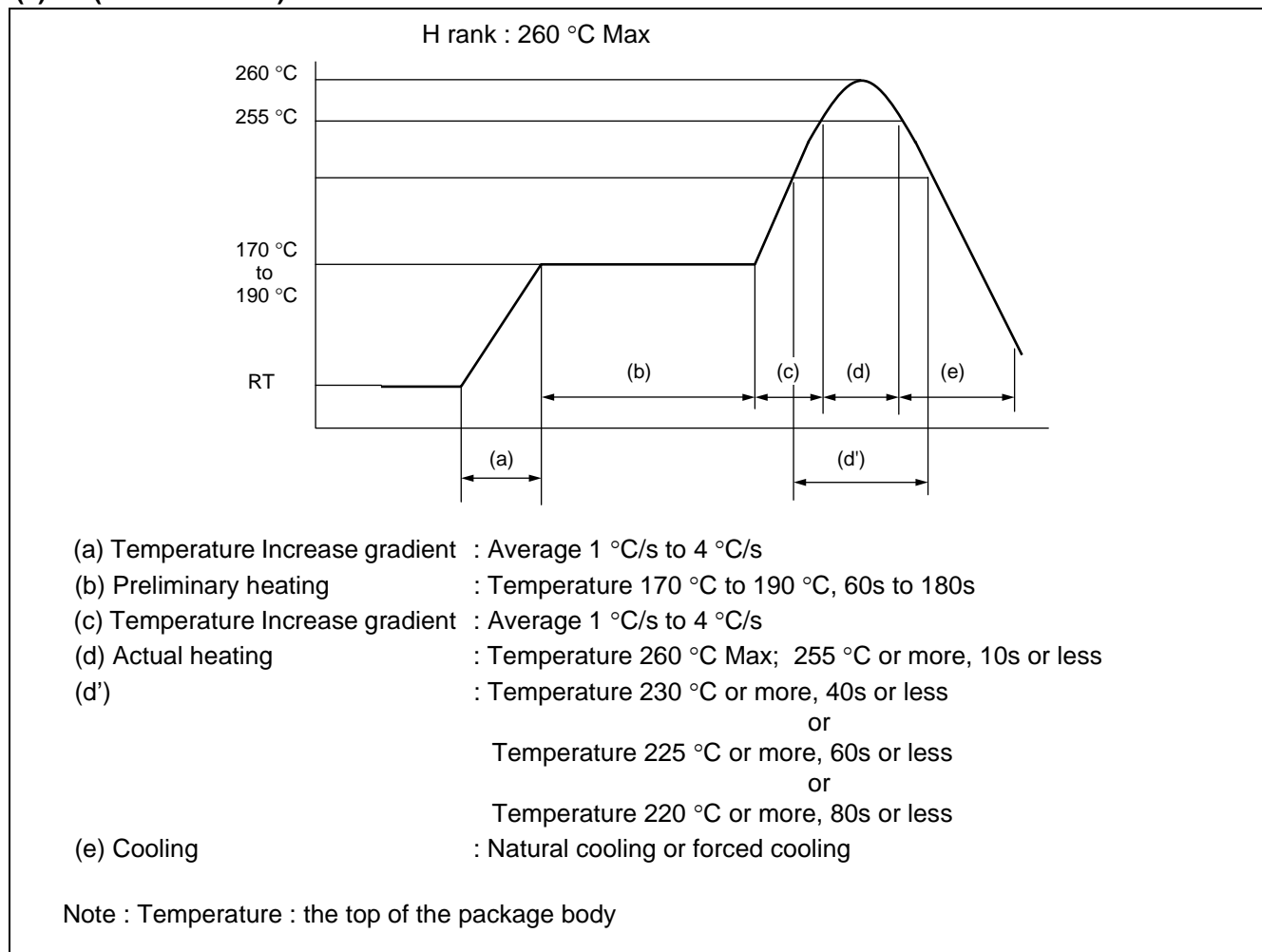

(2) Manual soldering (partial heating method)

Conditions : Temperature 400 °C Max

Times : 5 s max/pin

MB3769A

■ PACKAGE DIMENSION

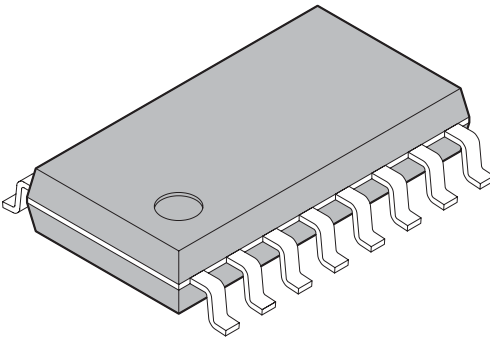
<p>16-pin plastic SOP</p>  <p>(FPT-16P-M06)</p>	Lead pitch	1.27 mm
	Package width × package length	5.3 × 10.15 mm
	Lead shape	Gullwing
	Sealing method	Plastic mold
	Mounting height	2.25 mm MAX
	Weight	0.20 g
	Code (Reference)	P-SOP16-5.3×10.15-1.27

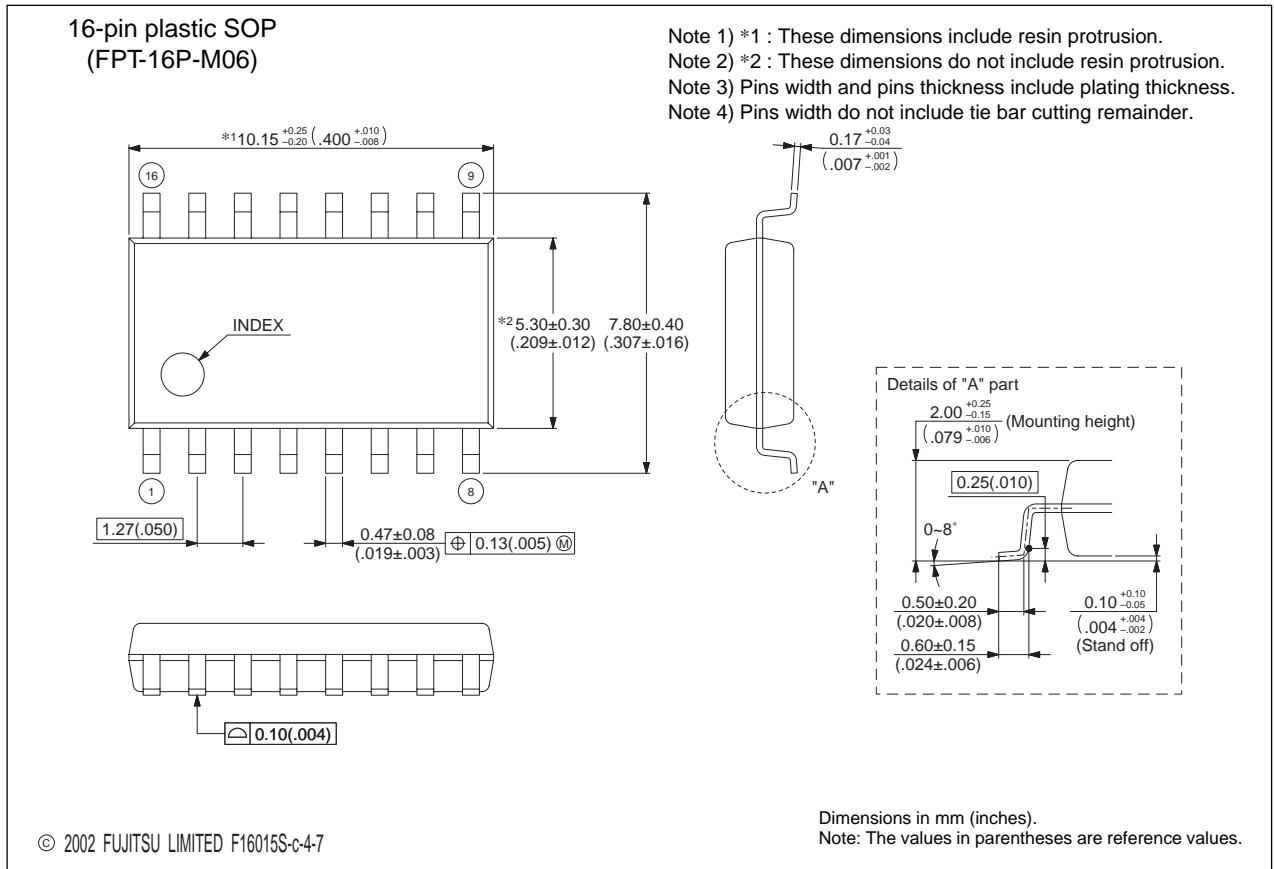

MEMO

MEMO



MEMO

FUJITSU MICROELECTRONICS LIMITED

Shinjuku Dai-Ichi Seimei Bldg. 7-1, Nishishinjuku 2-chome, Shinjuku-ku,
Tokyo 163-0722, Japan Tel: +81-3-5322-3347 Fax: +81-3-5322-3387
<http://jp.fujitsu.com/fml/en/>

For further information please contact:

North and South America

FUJITSU MICROELECTRONICS AMERICA, INC.
1250 E. Arques Avenue, M/S 333
Sunnyvale, CA 94085-5401, U.S.A.
Tel: +1-408-737-5600 Fax: +1-408-737-5999
<http://www.fma.fujitsu.com/>

Europe

FUJITSU MICROELECTRONICS EUROPE GmbH
Pittlerstrasse 47, 63225 Langen,
Germany
Tel: +49-6103-690-0 Fax: +49-6103-690-122
<http://emea.fujitsu.com/microelectronics/>

Korea

FUJITSU MICROELECTRONICS KOREA LTD.
206 KOSMO TOWER, 1002 Daechi-Dong,
Kangnam-Gu, Seoul 135-280
Korea
Tel: +82-2-3484-7100 Fax: +82-2-3484-7111
<http://www.fmk.fujitsu.com/>

Asia Pacific

FUJITSU MICROELECTRONICS ASIA PTE LTD.
151 Lorong Chuan, #05-08 New Tech Park,
Singapore 556741
Tel: +65-6281-0770 Fax: +65-6281-0220
<http://www.fujitsu.com/sg/services/micro/semiconductor/>

FUJITSU MICROELECTRONICS SHANGHAI CO., LTD.
Rm.3102, Bund Center, No.222 Yan An Road(E),
Shanghai 200002, China
Tel: +86-21-6335-1560 Fax: +86-21-6335-1605
<http://cn.fujitsu.com/fmc/>

FUJITSU MICROELECTRONICS PACIFIC ASIA LTD.
10/F., World Commerce Centre, 11 Canton Road
Tsimshatsui, Kowloon
Hong Kong
Tel: +852-2377-0226 Fax: +852-2376-3269
<http://cn.fujitsu.com/fmc/tw>

All Rights Reserved.

The contents of this document are subject to change without notice.

Customers are advised to consult with sales representatives before ordering.

The information, such as descriptions of function and application circuit examples, in this document are presented solely for the purpose of reference to show examples of operations and uses of FUJITSU MICROELECTRONICS device; FUJITSU MICROELECTRONICS does not warrant proper operation of the device with respect to use based on such information. When you develop equipment incorporating the device based on such information, you must assume any responsibility arising out of such use of the information.

FUJITSU MICROELECTRONICS assumes no liability for any damages whatsoever arising out of the use of the information.

Any information in this document, including descriptions of function and schematic diagrams, shall not be construed as license of the use or exercise of any intellectual property right, such as patent right or copyright, or any other right of FUJITSU MICROELECTRONICS or any third party or does FUJITSU MICROELECTRONICS warrant non-infringement of any third-party's intellectual property right or other right by using such information. FUJITSU MICROELECTRONICS assumes no liability for any infringement of the intellectual property rights or other rights of third parties which would result from the use of information contained herein.

The products described in this document are designed, developed and manufactured as contemplated for general use, including without limitation, ordinary industrial use, general office use, personal use, and household use, but are not designed, developed and manufactured as contemplated (1) for use accompanying fatal risks or dangers that, unless extremely high safety is secured, could have a serious effect to the public, and could lead directly to death, personal injury, severe physical damage or other loss (i.e., nuclear reaction control in nuclear facility, aircraft flight control, air traffic control, mass transport control, medical life support system, missile launch control in weapon system), or (2) for use requiring extremely high reliability (i.e., submersible repeater and artificial satellite).

Please note that FUJITSU MICROELECTRONICS will not be liable against you and/or any third party for any claims or damages arising in connection with above-mentioned uses of the products.

Any semiconductor devices have an inherent chance of failure. You must protect against injury, damage or loss from such failures by incorporating safety design measures into your facility and equipment such as redundancy, fire protection, and prevention of over-current levels and other abnormal operating conditions.

Exportation/release of any products described in this document may require necessary procedures in accordance with the regulations of the Foreign Exchange and Foreign Trade Control Law of Japan and/or US export control laws.

The company names and brand names herein are the trademarks or registered trademarks of their respective owners.