

PRELIMINARY

Chip Inductors - M0302CS Series (0805)

The M0302CS are ultra-small wirewound inductors with a 20% smaller footprint than our 0402 series inductors. These ceramic chip inductors have exceptionally high Q factors, especially at use frequencies and outstanding self-resonant frequencies. Despite their small size, they offer excellent current handling capability – up to 1.6 A.

This robust version features a high temperature encapsulant that allows operation in ambient temperature up to 155°C and a leach-resistant base metalization with 63/37 tin-lead terminations that ensure the best possible board adhesion.

Part number ¹	Inductance ² (nH)	Percent tolerance	900 MHz		1.7 GHz		2.4 GHz		SRF typ ⁴ (GHz)	DCR max ⁵ (Ohms)	I _{rms} ⁶ (mA)
			L typ	Q typ ³	L typ	Q typ ³	L typ	Q typ ³			
M0302CS-N67XKS_	0.67	10	0.66	42	0.66	56	0.67	70	>26	0.021	1600
M0302CS-1N7XJS_	1.7	5	1.7	57	1.7	78	1.7	95	16.14	0.038	1140
M0302CS-1N9XJS_	1.9	5	1.9	42	1.9	65	1.9	83	16.06	0.065	910
M0302CS-2N1XJS_	2.1	5	2.1	38	2.1	57	2.1	72	15.94	0.082	830
M0302CS-3N0XJS_	3.0	5	3.0	56	3.0	92	3.0	131	15.10	0.060	950
M0302CS-3N3XJS_	3.3	5	3.3	56	3.3	88	3.3	129	11.50	0.060	950
M0302CS-3N5XJS_	3.5	5	3.5	60	3.5	84	3.5	110	11.53	0.070	870
M0302CS-3N8XJS_	3.8	5	3.8	60	3.8	89	3.8	105	10.67	0.090	830
M0302CS-4N0XJS_	4.0	5	4.0	52	4.0	80	4.1	98	11.21	0.100	760
M0302CS-4N7XJS_	4.7	5	4.6	55	4.6	88	4.7	120	12.07	0.074	830
M0302CS-5N1XJS_	5.1	5	5.1	62	5.1	92	5.2	118	9.65	0.074	830
M0302CS-6N0XJS_	6.0	5	6.0	58	6.0	82	6.2	105	8.60	0.140	700
M0302CS-6N3XJS_	6.3	5	6.3	56	6.3	80	6.5	100	9.34	0.155	620
M0302CS-6N5XJS_	6.5	5	6.5	56	6.5	80	6.8	100	8.19	0.200	620
M0302CS-7N0XJS_	7.0	5	7.0	62	7.1	84	7.2	112	8.50	0.103	760
M0302CS-7N2XJS_	7.2	5	7.2	60	7.2	82	7.4	110	9.12	0.112	690
M0302CS-7N4XJS_	7.4	5	7.3	60	7.4	82	7.6	110	7.98	0.112	690
M0302CS-8N3XJS_	8.3	5	8.2	58	8.3	80	8.5	104	8.19	0.150	590
M0302CS-9N2XJS_	9.2	5	8.9	58	9.0	83	9.2	120	7.92	0.115	690
M0302CS-10NXJS_	10.0	5	10.0	58	10.1	91	10.2	119	7.45	0.140	620
M0302CS-11NXJS_	11.0	5	11.0	57	11.2	83	11.6	105	6.85	0.210	590
M0302CS-12NXJS_	12.0	5	12.0	59	12.6	88	12.7	110	6.86	0.170	560
M0302CS-13NXJS_	13.0	5	13.0	53	13.3	83	13.8	104	6.94	0.230	480
M0302CS-15NXJS_	15.0	5	15.0	55	15.4	84	15.9	106	6.20	0.174	560
M0302CS-16NXJS_	16.0	5	16.0	54	16.4	85	17.0	102	6.13	0.210	480
M0302CS-17NXJS_	17.0	5	16.9	52	17.4	82	18.2	118	6.26	0.280	440
M0302CS-18NXJS_	18.0	5	17.9	55	18.5	80	19.3	111	6.03	0.350	390
M0302CS-19NXJS_	19.0	5	18.9	53	19.6	85	20.5	104	5.79	0.260	480
M0302CS-20NXJS_	20.0	5	19.9	56	20.2	88	20.8	112	5.68	0.300	430
M0302CS-21NXJS_	21.0	5	20.9	53	22.0	82	24.1	95	5.16	0.370	370
M0302CS-22NXJS_	22.0	5	22.0	52	23.1	79	25.2	94	4.95	0.420	340
M0302CS-23NXJS_	23.5	5	23.5	54	24.6	84	27.4	92	5.18	0.400	430
M0302CS-29NXJS_	29.0	5	29.0	51	30.5	75	33.0	90	4.83	0.470	330
M0302CS-34NXJS_	34.0	5	34.0	55	35.5	78	38.1	94	4.45	0.530	310

1. When ordering, please specify **packaging** code:

M0302CS-34NXJS W

Packaging: **W** = 7" machine-ready reel with crush-resistant insert.
EIA-481 punched paper tape (2000 parts per full reel).
U = Less than full reel. In tape, but not machine ready.
To have a leader and trailer added (\$25 charge),
use code letter **W** instead.

2. Inductance measured at 250 MHz using a Coilcraft SMD-F fixture in an Agilent/HP 4286 impedance analyzer with Coilcraft-provided correlation pieces.

3. Q measured using an Agilent/HP 4287A with an Agilent/HP 16193 test fixture.

4. SRF measured using an Agilent/HP 8722ES network analyzer and a test fixture with a 0.017" air gap.

5. DCR measured on a micro-ohmmeter and a Coilcraft CCF858 test fixture.

6. Current that causes a 30°C temperature rise from 25°C ambient.

7. **Ambient temperature range:** -55°C to +140°C with I_{rms} current
+140°C to +155°C with derated current

8. **Storage temperature range:** Component: -55°C to +155°C
Packaging: -55°C to +80°C

9. **Resistance to soldering heat:** Three reflows at >217°C for 90 seconds (+260°C ±5°C for 20 – 40 seconds), allowing parts to cool to room temperature between.

10. Electrical specifications at 25°C.

Refer to Doc 362 "Soldering Surface Mount Components" before soldering.



© Coilcraft, Inc. 2007

Specifications subject to change without notice.

Please check our website for latest information. Document M302-1 Revised 09/25/07

1102 Silver Lake Road
Cary IL 60013

Phone 800-981-0363
Fax 847-639-1508

E-mail cp@coilcraft.com
Web www.coilcraft.com/cp

PRELIMINARY

M0302CS Series (0805)

S-Parameter files
ON OUR WEB SITE OR CD
SPICE models
ON OUR WEB SITE OR CD

Typical L vs Frequency

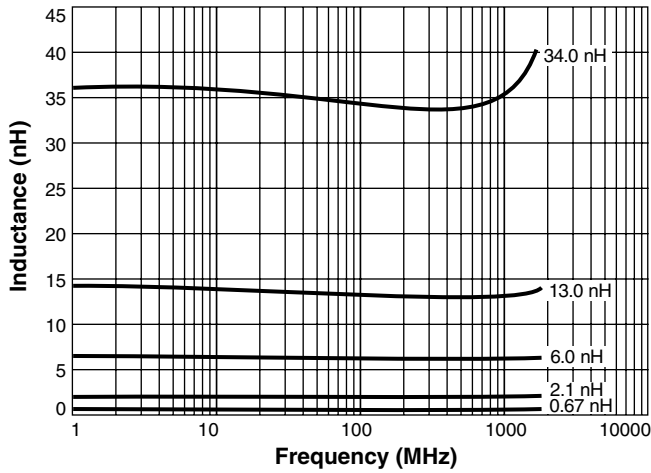

Typical Q vs Frequency

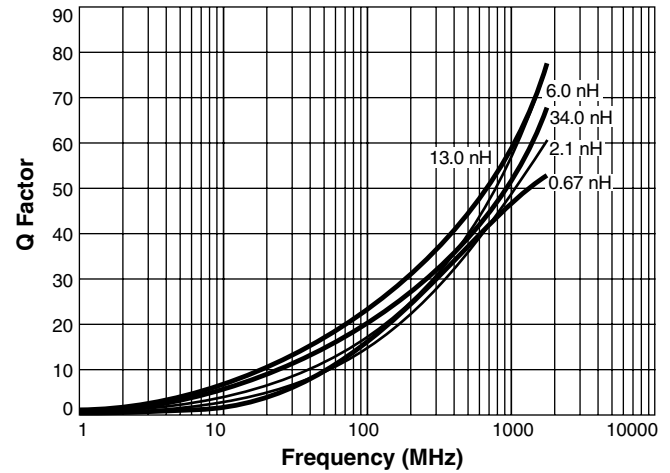

Irms Derating

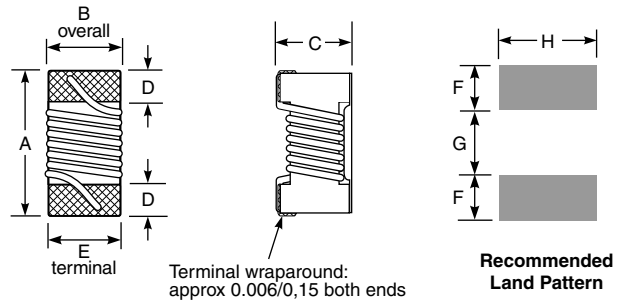
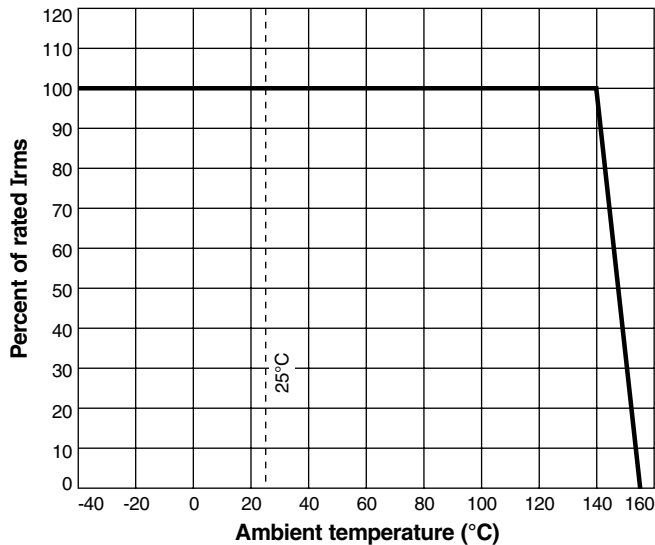

A max	B max	C max	D	E	F	G	H
0.034	0.018	0.018	0.006	0.015	0.010	0.014	0.021
0,86	0,46	0,45	0,20	0,38	0,25	0,36	0,53

Weight: 0.4 – 0.5 mg
Terminations: Tin-lead (63/37) over silver-palladium-platinum-glass frit
Tape and reel: 2000/7" reel 8 mm tape width
 For packaging data see Tape and Reel Specifications section.

