

Surface Mount 5x7mm LVDS Clock Oscillator

CONNOR WINFIELD



2111 Comprehensive Drive
Aurora, Illinois 60505
Phone: 630-851-4722
Fax: 630-851-5040
www.conwin.com
US Headquarters:
630-851-4722
European Headquarters:
+353-61-472221

Description:

The Connor Winfield Lxxx - Series is a 5x7 mm Surface Mount, LVDS, Fixed Frequency Crystal Controlled Oscillator (XO) designed for applications requiring tight frequency stability, wide temperature range and low jitter. Operating at 2.5V or 3.3V supply voltage, the Lxxx - Series provides an LVDS Differential Outputs with enable / disable function. The surface mount package is designed for high-density mounting and is optimum for mass production.



Features:

Model Lxxx - Series
5.0 x7.0mm Surface Mount Package
2.5V or 3.3V Operation
LVDS Output Logic
Frequency Stabilities Available:
+/-20ppm, +/-25ppm, +/-50ppm, +/-100ppm
Temperature Ranges Available:
0 to 70°C, -40 to 85°C, 0 to 85°C, -20 to 70°C
Low Jitter <1pS RMS
Tri-State Enable/Disable on Pad 1 or 2
Tape and Reel Packaging
RoHS Compliant / Lead Free

Absolute Maximum Ratings

Parameter	Minimum	Nominal	Maximum	Units	Notes
Storage Temperature	-55	-	125	°C	
Supply Voltage (Vcc)	-0.5	-	4.6	Vdc	
Input Voltage (Vc)	-0.5	-	Vcc + 0.5	Vdc	

Operating Specifications

Parameter	Minimum	Nominal	Maximum	Units	Notes
Output Frequency (Fo)	19.44	-	260	MHz	
Total Frequency Tolerance	(See Ordering Information for full part number)				
Model Lx4x	-20	-	20	ppm	1
Model Lx1x	-25	-	25	ppm	1
Model Lx2x	-50	-	50	ppm	1
Model Lx3x	-100	-	100	ppm	1
Operating Temperature Range					
Model L1xx	0	-	70	°C	
Model L2xx	-40	-	85	°C	
Model L3xx	0	-	85	°C	
Model L4xx	-20	-	70	°C	
Supply Voltage (Vcc)					
Model Lxx2 E/D Pad 1		2.375	2.5	2.625	Vdc
Model Lxx3 E/D Pad 1		3.135	3.3	3.465	Vdc
Model Lxx4 E/D Pad 2		2.375	2.5	2.625	Vdc
Model Lxx5 E/D Pad 2		3.135	3.3	3.465	Vdc
Supply Current (Icc)	-	45	65	mA	
Jitter:					
Period Jitter	-	2.5	3.5	ps RMS	
Integrated Phase Jitter (BW = 12 KHz to 20 MHz)					
Fo ≥ 100 MHz	-	0.5	0.7	ps RMS	
80 MHz ≤ Fo ≤ 100 MHz	-	0.8	1.0	ps RMS	
Fo <80 MHz	-	1.5	2.5	ps RMS	
SSB Phase Noise					
@ 10 Hz offset	-	-60	-	dBc/Hz	
@ 100 Hz offset	-	-90	-	dBc/Hz	
@ 1 KHz offset	-	-115	-	dBc/Hz	
@ 10 KHz offset	-	-140	-	dBc/Hz	
@ 100 KHz offset	-	-145	-	dBc/Hz	
Start-Up Time	-	5	10	ms	

Input Characteristics

Parameter	Minimum	Nominal	Maximum	Units	Notes
Enable Input Voltage - (High) - (Vih)	70%Vcc	-	-	Vdc	2
Disable Input Voltage - (Low) - (Vil)	-	-	30%Vcc	Vdc	2
Enable Time	-	-	500	us	
Disable Time	-	-	200	ns	
Standby Current (When Osc. is disabled)	-	-	30	uA	

LVDS Output Characteristics

Parameter	Minimum	Nominal	Maximum	Units	Notes
Load	-	100	-	Ohm	
Output Differential Voltage (Vod)	250	-	450	mV	3
Output Swing (Dif. Output Pk to Pk)	500	700	900	mV	
Duty Cycle at 50% Level	45	50	55	%	4
Differential Rise / Fall Time: 20% to 80%	-	0.3	0.7	ns	

Notes:

- Includes calibration @ 25°C, frequency stability vs. change in temperature, supply voltage and load variations, shock and vibration and 20 years aging.
- When the oscillator is disabled the outputs are at high impedance. Outputs are enabled with no connection on pad 1.
- Vod is measured with a 100 ohm resistor between the true and the complementary outputs.
- Duty cycle measured at 50% of output voltage swing.

Specifications subject to change without notice. All dimensions in inches. © Copyright 2009 The Connor-Winfield Corporation



Bulletin **DS021**
Page **1 of 2**
Revision **08**
Date **02 Dec 2009**



Ordering Information

L	1	4	3	- 155.52M
Type LVDS Clock Series 5x7mm	Temperature Range 1 = 0 to 70°C 2 = -40 to 85°C 3 = 0 to 85°C 4 = -20 to 70°C	Frequency Stability 4 = ±20 ppm 1 = ±25 ppm 2 = ±50 ppm 3 = ±100 ppm	Supply Voltage 2 = 2.5 Vdc, E/D Pad 1 3 = 3.3 Vdc, E/D Pad 1 4 = 2.5 Vdc, E/D Pad 2 5 = 3.3 Vdc, E/D Pad 2	Output Frequency Frequency Format -xxx.xM Min -xxx.xxxxxM Max *Amount of numbers after the decimal point. M = MHz

Example: Part Number
L143-155.52M = LVDS Output,
0 to 70, +/-20ppm, 3.3Vdc, E/D Pad 1, Output Frequency 155.52MHz

To order an L143 with an output frequency of:
25 MHz = L143-025.0M
44.736 MHz = L143-044.736M
155.52 MHz = L143-155.52M

Package Characteristics

Package Hermetically sealed ceramic package and metal cover

Environmental Characteristics

Vibration: Vibration per Mil Std 883E Method 2007.3 Test Condition A.
Shock: Mechanical Shock per Mil Std 883E Method 2002.4 Test Condition B.
Soldering Process: RoHS compliant lead free. See soldering profile on page 2.
Solderability: Solderability per Mil Std 883E Method 2003.

Enable / Disable Function

Function: Output
Low: Disabled (High Impedance)
High or Open: Enabled

Models: Lxx2, Lxx3

1: Enable / Disable
2: N/C
3: Ground
4: Output Q
5: Complementary Output \bar{Q}
6: Supply Voltage (Vcc)

Models: Lxx4, Lxx5

1: N/C
2: Enable / Disable
3: Ground
4: Output Q
5: Complementary Output \bar{Q}
6: Supply Voltage (Vcc)

Package Outline

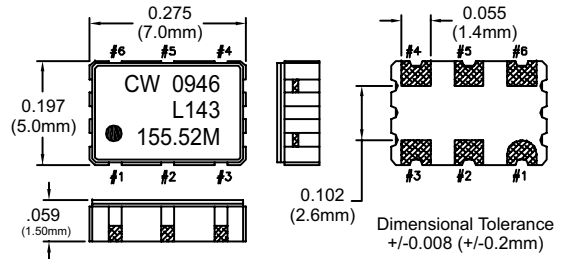

Suggested Pad Layout

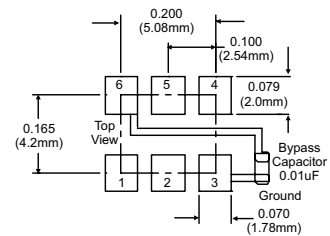

Pad Connections

Output Waveform

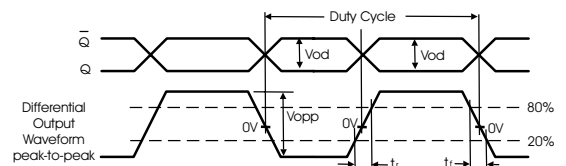

Test Circuit

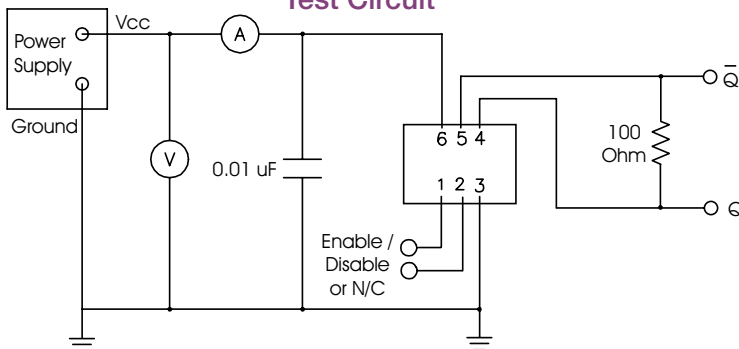

Tape and Reel Dimensions

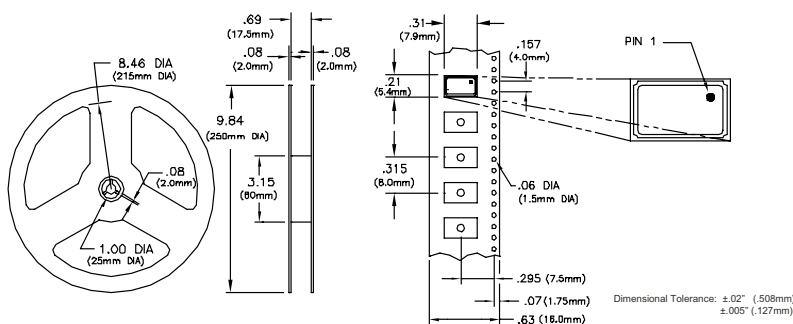

MEETS EIA-481A AND EIAJ-1009B
2,000 PCS/REEL

Solder Profile

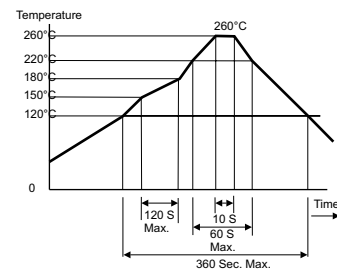

Bulletin **Ds021**
Page **2 of 2**
Revision **08**
Date **02 Dec 2009**