

### 4006

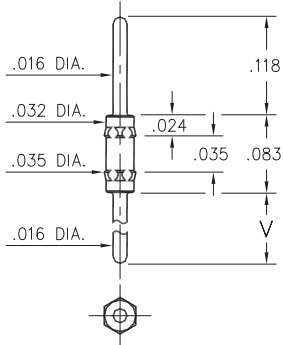

Basic Part Number	Length V
4006-0	.118
4006-1	.188
4006-2	.288

**4006-X-00-XX-00-00-03-0**  
Hex Press-fit in .034 mounting hole

### 3121

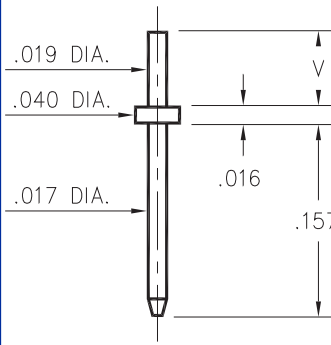

Basic Part Number	Substrate Thickness	Length V
3121-1	.025	.061
3121-2	.040	.075

**3121-X-00-XX-00-00-08-0**  
Solder mount in .023 mounting hole  
Material is annealed.

### 3128

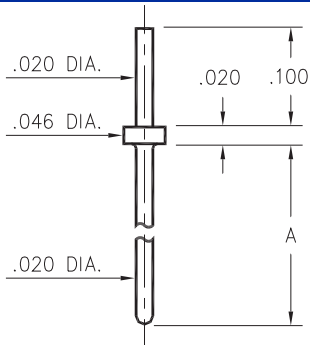

Basic Part Number	Length A
3128-1	.250
3128-2	.425
3128-3	.525
3128-4	.550
3128-5	.930

**3128-X-00-XX-00-00-08-0**  
Solder mount in .024 min. mounting hole

### 3006

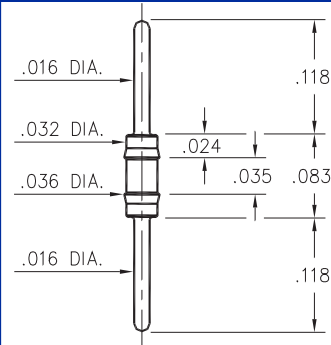

**3006-0-00-XX-00-00-03-0**  
Press-fit in .034 mounting hole

### 8885

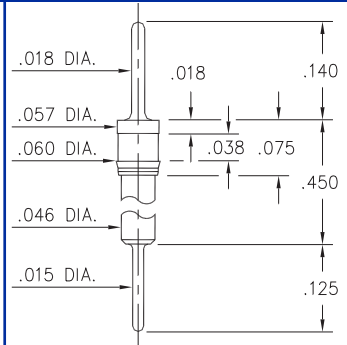

**8885-0-00-XX-00-00-03-0**  
Press-fit in .057 mounting hole

### 6218

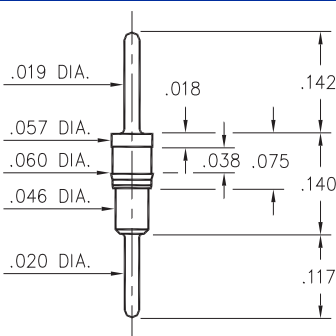

**6218-0-00-XX-00-00-03-0**  
Press-fit in .057 mounting hole

### 5012

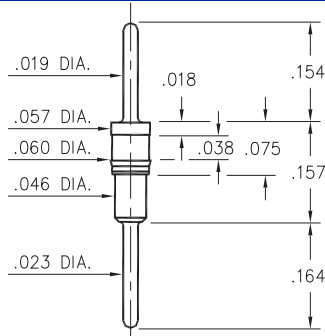

**5012-0-00-XX-00-00-03-0**  
Press-fit in .057 mounting hole

### 0508

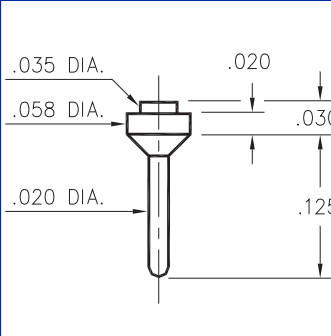

**0508-0-00-XX-00-00-03-0**  
Surface Mount

### 9081

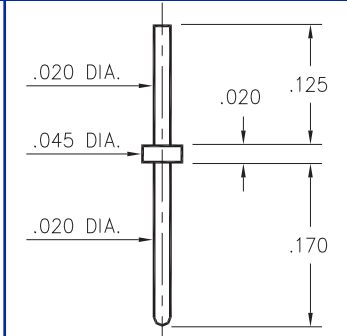

**9081-0-00-XX-00-00-08-0**  
Solder mount in .024 mounting hole

## SPECIFICATIONS

**PIN MATERIAL:**  
Brass Alloy 360, 1/2 Hard  
(Except where noted)

**DIMENSION IN INCHES**  
**TOLERANCES ON:**  
LENGTHS: ±.005  
DIAMETERS: ±.002  
ANGLES: ± 2°

**ORDER CODE: XXXX - X - 00 - XX - 00 - 00 - XX - 0**

**BASIC PART #**

**SPECIFY PIN FINISH:**

- 01 200µ" TIN/LEAD OVER NICKEL
- ◇ 80 200µ" TIN OVER NICKEL (RoHS)
- ◇ 15 10µ" GOLD OVER NICKEL (RoHS)
- ◇ 21 20µ" GOLD OVER NICKEL (RoHS)
- ◇ 34 50µ" GOLD OVER NICKEL (RoHS)

