

C-1XX-1250(C)-FDFB-SLCX



Features

- Duplex LC Single Mode Transceiver
- Small Form Factor Multi-sourced 2x5 Pin Package
- Complies with IEEE 802.3 Gigabit Ethernet
- 1270 nm to 1610 nm Wavelength, CWDM DFB Laser
- Single +3.3V Power Supply
- LVPECL Differential Inputs and Outputs
- LVTTTL Signal Detection Output (C-1XX-1250C-FDFB-SLCX)
- LVPECL Signal Detection Output (C-1XX-1250-FDFB-SLCX)
- Temperature Range: 0 to 70 °C
- Class 1 Laser International Safety Standard IEC 825 compliant
- Solderability to MIL-STD-883, Method 2003
- Pin Coating is Sn/Pb with minimum 2% Pb content
- Flammability to UL94V0
- Humidity RH 5-85% (5-90% short term) to IEC 68-2-3
- Complies with Bellcore GR-468-CORE
- Uncooled laser diode with MQW structure
- 1.25 Gbps Ethernet Links application
- 1.06 Gbps Fiber Channel application

Absolute Maximum Rating

Parameter	Symbol	Min.	Max.	Unit	Note
Power Supply Voltage	V_{cc}	0	3.6	V	
Output Current	I_{out}	0	30	mA	
Soldering Temperature	-	-	260	°C	10 seconds on leads only
Operating Temperature	T_{opr}	0	70	°C	
Storage Temperature	T_{stg}	-40	85	°C	

Recommended Operating Condition

Parameter	Symbol	Min.	Typ.	Max.	Unit
Power Supply Voltage	V_{cc}	3.1	3.3	3.5	V
Operating Temperature (Case)	T_{opr}	0	-	70	°C
Data rate		-	1250	-	Mbps

C-1XX-1250(C)-FDFB-SLCX

Transmitter Specifications

Parameter	Symbol	Min	Typical	Max	Unit	Notes
Optical						
Optical Transmit Power	P_o	-5	-	0	dBm	C-1XX-1250(C)-FDFB-SLC2
Optical Transmit Power	P_o	-3	-	+2	dBm	C-1XX-1250(C)-FDFB-SLC3
Optical Transmit Power	P_o	0	-	+5	dBm	C-1XX-1250(C)-FDFB-SLC4
Output center Wavelength	λ	$\lambda_p-5.5$	λ_p	$\lambda_p+7.5$	nm	$\lambda_p=1XX0$ nm, C-1XX-1250(C)-FDFB-SLCX
Output Spectrum Width	$\Delta\lambda$	-	-	1	nm	-20 dB width
Side Mode Suppression Ratio	Sr	30	35	-	dBm	CW, $P_o=5$ mW
Extinction Ratio	ER	9	-	-	dB	
Output Eye		Compliant with IEEE 802.3				
Optical Rise Time	t_r	-	-	0.26	ns	20% to 80% Values
Optical Fall Time	t_f	-	-	0.26	ns	20% to 80% Values
Relative Intensity Noise	RIN	-	-	-120	dB/Hz	
Total Jitter	TJ	-	-	0.27	ns	Measured with 2^7-1 PRBS

Transmitter Specifications

Parameter	Symbol	Min	Typical	Max	Unit	Notes
Electrical						
Power Supply Current	I_{CC}	-	-	180	mA	Maximum current is specified at V_{CC} = Maximum @ maximum temperature
Transmit Enable Voltage	V_{EN}	0	-	0.8	V	
Transmit Disable Voltage	V_D	2.0	-	V_{CC}	V	
Data Input Current-Low	I_{IL}	-200	-	-	μ A	
Data Input Current-High	I_{IH}	-	-	200	μ A	
Data Input Voltage-Low	$V_{IL-V_{CC}}$	-2.0	-	-1.58	V	These inputs are compatible with 10K, 10KH and 100K ECL and PECL inputs
Data Input Voltage-High	$V_{IH-V_{CC}}$	-1.1	-	-0.74	V	

Receiver Specifications

Parameter	Symbol	Min	Typical	Max	Unit	Notes
Optical						
Sensitivity	-	-	-	-22	dBm	Measured with 2^7-1 PRBS, BER = 10^{-12}
Maximum Input Power	P_{in}	-3	-	-	dBm	
Signal Detect-Asserted	P_a	-	-	-22	dBm	Measured on transition: low to high
Signal Detect-Deasserted	P_d	-38	-	-	dBm	Measured on transition: high to low
Signal Detect-Hysteresis		1.0	-	-	dB	
Wavelength of Operation		1100	-	1620	nm	

C-1XX-1250(C)-FDFB-SLCX

Receiver Specifications

Parameter	Symbol	Min	Typical	Max	Unit	Note
Electrical						
Power Supply Current	I_{CC}	-	-	120	mA	The current excludes the output load current
Data Output Voltage-Low	$V_{OL} - V_{CC}$	-2	-	-1.58	V	These outputs are compatible with 10K, 10KH and 100K ECL and LVPECL outputs
Data Output Voltage-High	$V_{OH} - V_{CC}$	-1.1	-	-0.74	V	
Signal Detect Output Voltage-Low	$V_{SDL} - V_{CC}$	-2	-	-1.58	V	C-1XX-1250-FDFB-SLCX
Signal Detect Output Voltage-High	$V_{SDH} - V_{CC}$	-1.1	-	-0.74	V	
Signal Detect Output Voltage-Low	$V_{SDL} - V_{CC}$	-	-	0.5	V	C-1XX-1250C-FDFB-SLCX
Signal Detect Output Voltage-High	$V_{SDH} - V_{CC}$	2.0	-	-	V	

Connection Diagram

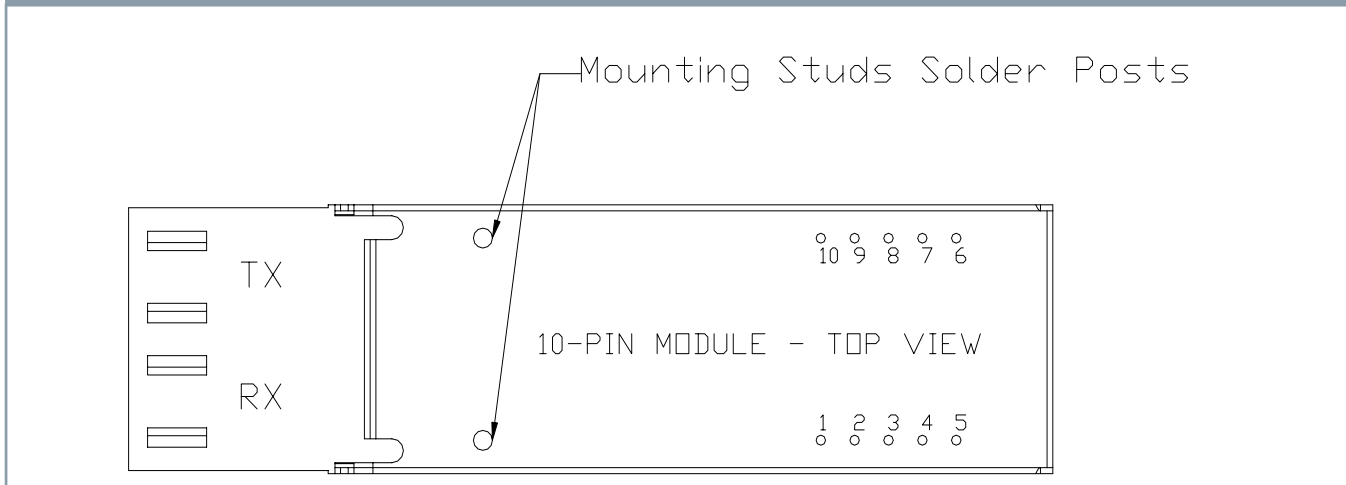

PIN	Symbol	Notes
1	RxGND	Directly connect this pin to the receiver ground plane
2	TxVcc	+3.3 V dc power for the receiver section
3	SD	Active high on this indicates a received optical signal(LVPECL/LVTTL)
4	RD-	Receiver Data Out Bar (LVPECL)
5	RD+	Receiver Dat Out (LVPECL)
6	TxVcc	+3.3 V dc power for the transmitter section
7	TxGND	Directly connect this pin to the transmitter ground plane
8	TxDIS	Transmitter disable (LVTTL)
9	TD+	Transmitter Data In (LVPECL)
10	TD-	Transmitter Data In Bar (LVPECL)
Attaching Posts		The attaching posts are at case potential and may be connected to chassis ground. They are isolated from circuit ground.

C-1XX-1250(C)-FDFB-SLCX

Recommended Circuit Schematic

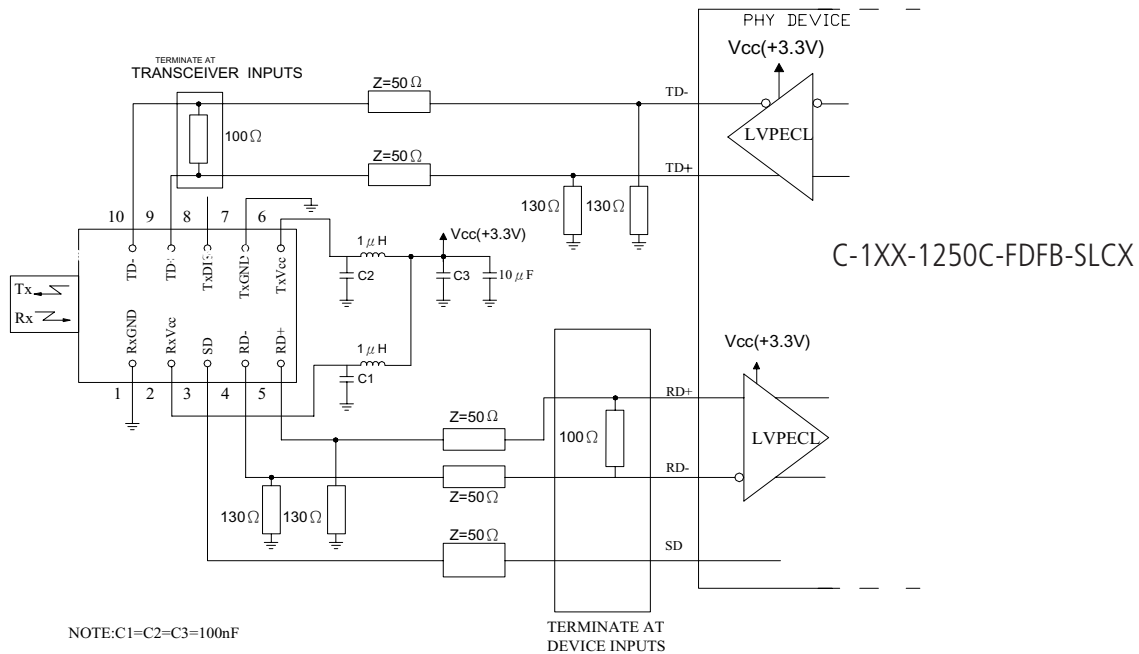
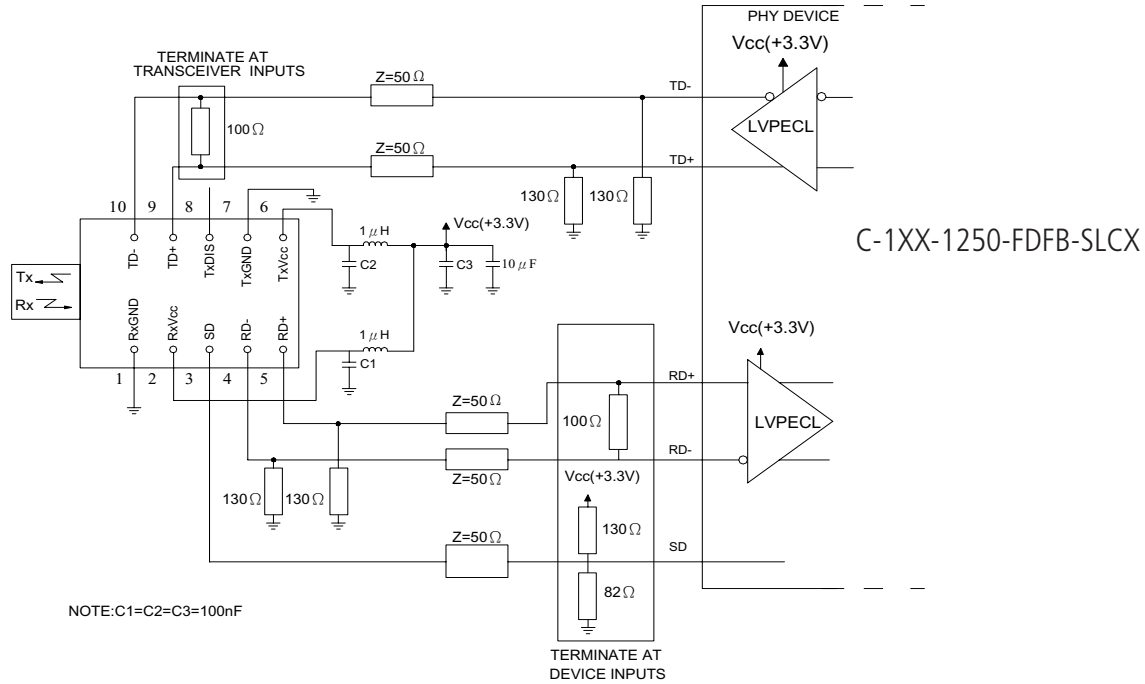

The split-loaded terminations for ECL signals need to be located at the input of devices receiving those ECL signals. The power supply filtering is required for good EMI performance. Use short tracks from the inductor L1/L2 to the module Rx Vcc and Tx Vcc. A GND plane under the module is required for good EMI and sensitivity performance.

C-1XX-1250(C)-FDFB-SLCX

Package Diagram

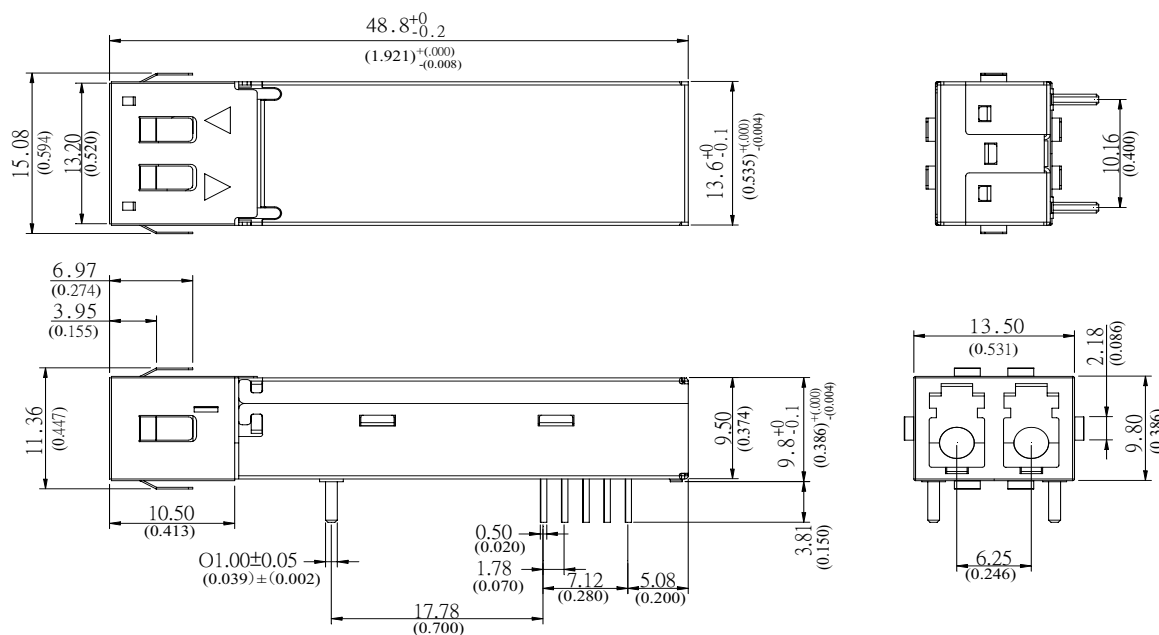

Units in mm(inch)

Printed Circuit Board Layout Consideration

A fiber-optic receiver employs a very high gain, wide bandwidth transimpedance amplifier. This amplifier detects and amplifies signals that are only tens of nA in amplitude when the receiver is operating near its limit. Any unwanted signal current that couples into the receiver circuitry causes a decrease in the receiver's sensitivity and can also degrade the performance of the receiver's signal detect (SD) circuit. To minimize the coupling of unwanted noise into the receiver, careful attention must be given to the printed circuit board.

At a minimum, a double-sided printed circuit board (PCB) with a large component side ground plane beneath the transceiver must be used. In applications that include many other high speed devices, a multi-layer PCB is highly recommended. This permits the placement of power and ground on separate layers, which allows them to be isolated from the signal lines. Multilayer construction also permits the routing of signal traces away from high level, high speed signal lines. To minimize the possibility of coupling noise into the receiver section, high level, high speed signals such as transmitter inputs and clock lines should be routed as far away as possible from the receiver pins.

Noise that couples into the receiver through the power supply pins can also degrade performance. It is recommended that a pi filter be used in both transmitter and receiver power supplies.

EMI and ESC Consideration

LuminentOIC transceivers offer a metalized plastic case and a special chassis grounding clip. As shown in the drawing, this clip connects the module case to chassis ground then installs flush through the panel cutout. This way, the grounding clip brushes the edge of the cutout in order to make a proper contact. The use of a grounding clip also provides increased electrostatic protection and helps reduce radiated emission from the module or the host circuit board through the chassis faceplate. The attaching posts are at case potential and may be connected to chassis ground. They should not be connected to circuit ground.

Plastic optical subassemblies are used to further reduce the possibility of radiated emission by eliminating the metal from the transmitter and receiver diode housings, which extend into connector space. By providing a non-metal receptacle for the optical cable ferrule, the gigabit speed RF electrical signal is isolated from the connector area thus preventing radiated energy leakage from these surfaces to the outside of the panel.

C-1XX-1250(C)-FDFB-SLCX

Ordering Information

Part numbering Definition:

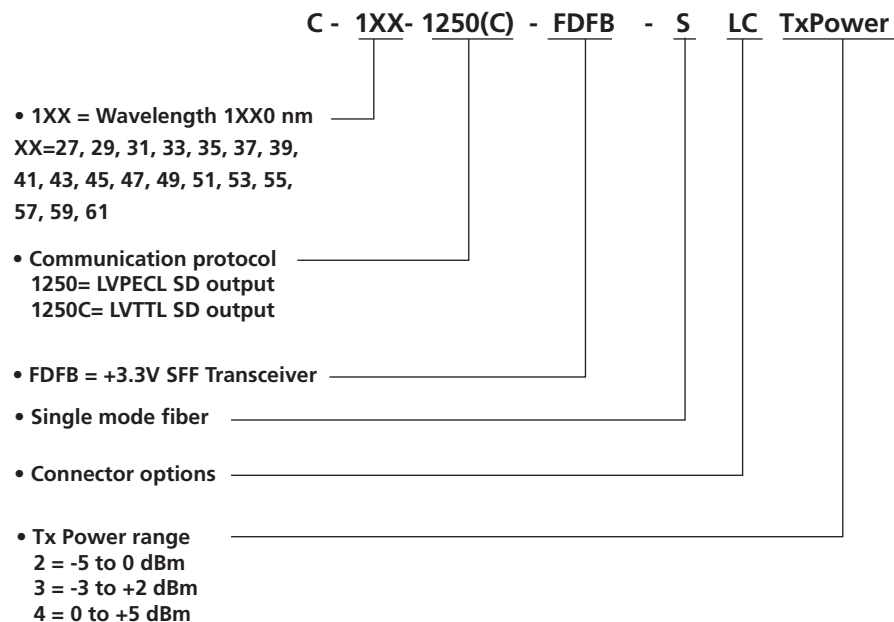

- Available Options:**
- C-1XX-1250-FDFB-SLC2
 - C-1XX-1250-FDFB-SLC3
 - C-1XX-1250-FDFB-SLC4
 - C-1XX-1250C-FDFB-SLC2
 - C-1XX-1250C-FDFB-SLC3
 - C-1XX-1250C-FDFB-SLC4

Warnings:

Handling Precautions: This device is susceptible to damage as a result of electrostatic discharge (ESD). A static free environment is highly recommended. Follow guidelines according to proper ESD procedures.

Laser Safety: Radiation emitted by laser devices can be dangerous to human eyes. Avoid eye exposure to direct or indirect radiation.

Legal Notes:

IMPORTANT NOTICE!

All information contained in this document is subject to change without notice, at LuminentOIC’s sole and absolute discretion. LuminentOIC warrants performance of its products to current specifications only in accordance with the company’s standard one-year warranty; however, specifications designated as “preliminary” are given to describe components only, and LuminentOIC expressly disclaims any and all warranties for said products, including express, implied, and statutory warranties, warranties of merchantability, fitness for a particular purpose, and non-infringement of proprietary rights. Please refer to the company’s Terms and Conditions of Sale for further warranty information.

LuminentOIC assumes no liability for applications assistance, customer product design, software performance, or infringement of patents, services, or intellectual property described herein. No license, either express or implied, is granted under any patent right, copyright, or intellectual property right, and LuminentOIC makes no representations or warranties that the product(s) described herein are free from patent, copyright, or intellectual property rights. Products described in this document are NOT intended for use in implantation or other life support applications where malfunction may result in injury or death to persons. LuminentOIC customers using or selling products for use in such applications do so at their own risk and agree to fully defend and indemnify LuminentOIC for any damages resulting from such use or sale.

THE INFORMATION CONTAINED IN THIS DOCUMENT IS PROVIDED ON AN “AS IS” BASIS. Customer agrees that LuminentOIC is not liable for any actual, consequential, exemplary, or other damages arising directly or indirectly from any use of the information contained in this document. Customer must contact LuminentOIC to obtain the latest version of this publication to verify, before placing any order, that the information contained herein is current.

© LuminentOIC, Inc. 2003
All rights reserved