

SPECIFICATIONS

Mechanical

Operating Force: 150±100gf

Travel: 1.5±0.3mm

Durability: 10000 Cycles min.

Electrical

Current Rating: DC 4V, 0.3A

Contact Resistance: initial 70m max.

Insulation Resistance: 100M min.(100V DC 1 Minute)

Dielectric Withstanding Voltage: 100V AC For 1Minute

Physical

Operating Temperatures: -10 to +60

Package: 3000Pcs/Reel, 10Rreel/Package

Slide Switch

**1BS007 Series
Horizontal, SMT Type
1.5mm [.059"] Pitch**

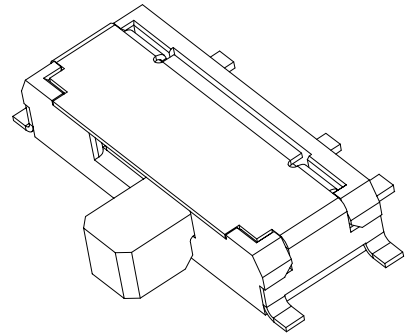

DRAWING

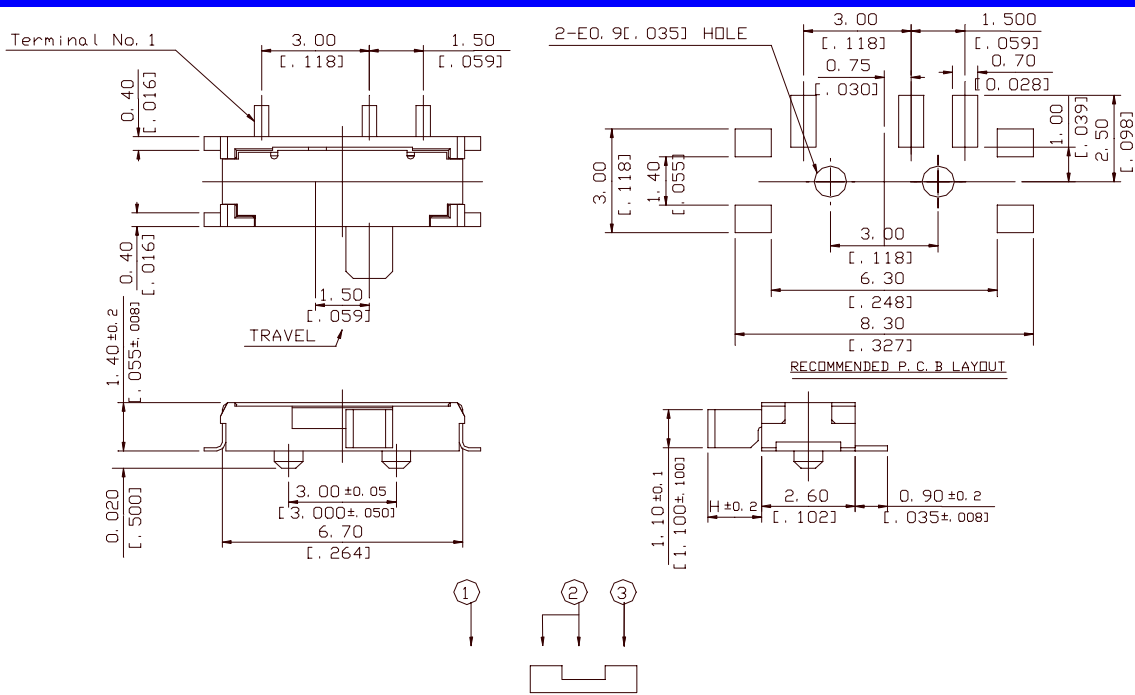

CIRCUIT DIAGRAM

ORDERING INFORMATION

PRODUCT NO.: 1BS007 - * * * * * - * * * - * *

