2 Mbit 1.8V SPI Serial Flash

Features

- Single Voltage Read and Write Operations
 - 1.65-1.95V
- Serial Interface Architecture
 - SPI Compatible: Mode 0 and Mode 3
- High Speed Clock Frequency
 - 40MHz
- Superior Reliability
 - Endurance: 100,000 Cycles
 - Greater than 20 years Data Retention
- Ultra-Low Power Consumption:
 - Active Read Current: 4 mA (typical)
 - Standby Current: 10 μ A (typical)
 - Power-down Mode Standby Current: 4 μ A (typical)
- Flexible Erase Capability
 - Uniform 4 KByte sectors
 - Uniform 64 KByte overlay blocks
- Page Program Mode
 - 256 Bytes/Page
- Fast Erase and Page-Program:
 - Chip-Erase Time: 300 ms (typical)
 - Sector-Erase Time: 40 ms (typical)
 - Block-Erase Time: 80 ms (typical)
 - Page-Program Time: 3 ms/ 256 bytes (typical)
- End-of-Write Detection
 - Software polling the BUSY bit in Status Register
- Hold Pin (HOLD#)
 - Suspend a serial sequence without deselecting the device
- Write Protection (WP#)
 - Enables/Disables the Lock-Down function of the status register
- Software Write Protection
 - Write protection through Block-Protection bits in status register
- Temperature Range
 - Industrial: -40°C to +85°C

- Packages Available
 - 8-lead SOIC (150 mils)
 - 8-contact USON (2mm x 3mm)
- All devices are RoHS compliant

Product Description

SST25WF020A is a member of the Serial Flash 25 Series family and feature a four-wire, SPI-compatible interface that allows for a low pin-count package which occupies less board space and ultimately lowers total system costs. SPI serial flash memory is manufactured with proprietary, high-performance CMOS SuperFlash technology. The split-gate cell design and thick-oxide tunneling injector attain better reliability and manufacturability compared with alternate approaches.

This Serial Flash significantly improve performance and reliability, while lowering power consumption. The device writes (Program or Erase) with a single power supply of 1.65-1.95V. The total energy consumed is a function of the applied voltage, current, and time of application. Since for any given voltage range, the SuperFlash technology uses less current to program and has a shorter erase time, the total energy consumed during any Erase or Program operation is less than alternative flash memory technologies.

SST25WF020A is offered in 8-lead SOIC and 8-contact USON packages. See [Figure 2-1](#) for the pin assignments.

1.0 FUNCTIONAL BLOCK DIAGRAM

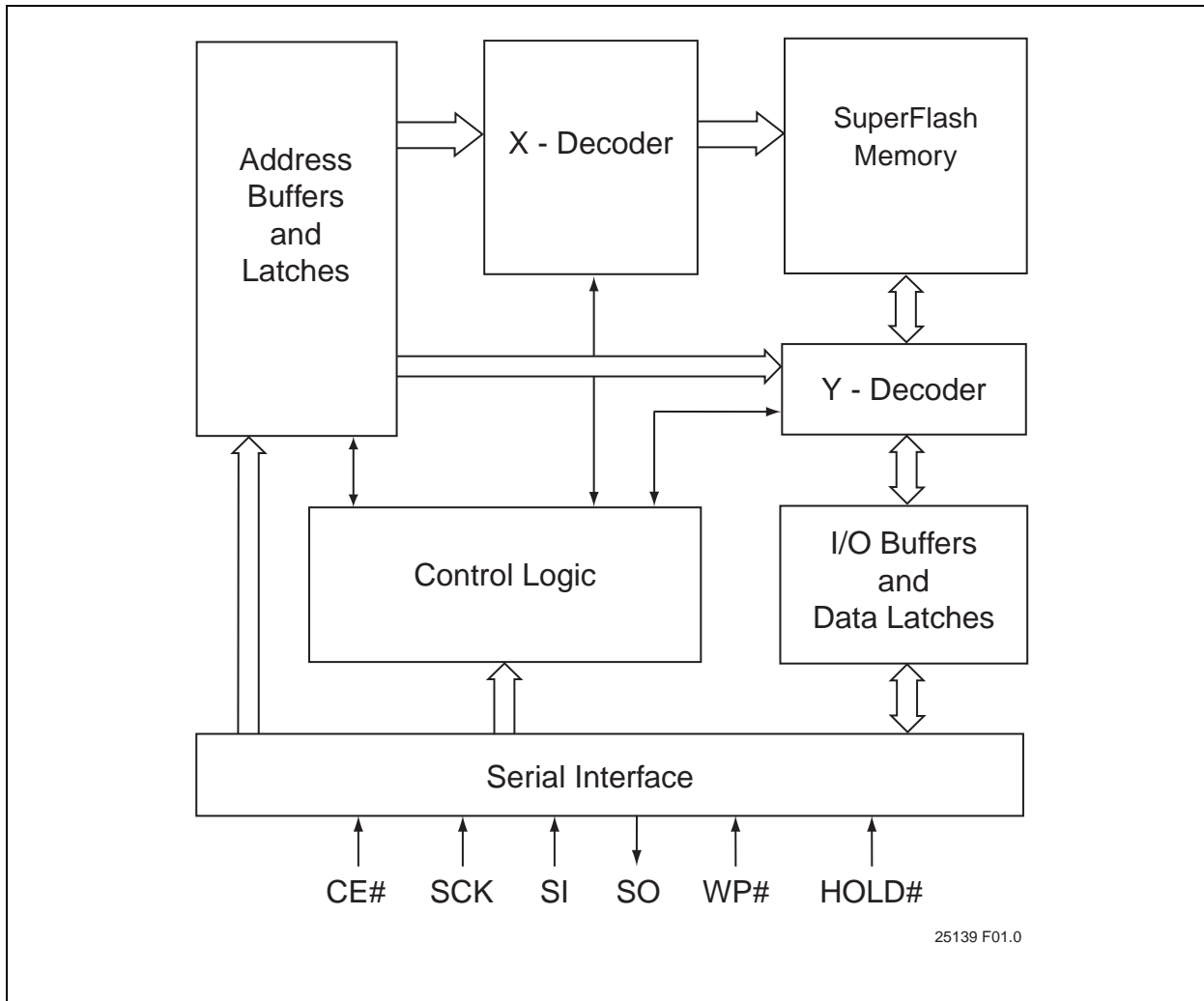

FIGURE 1-1: FUNCTIONAL BLOCK DIAGRAM

2.0 PIN DESCRIPTION

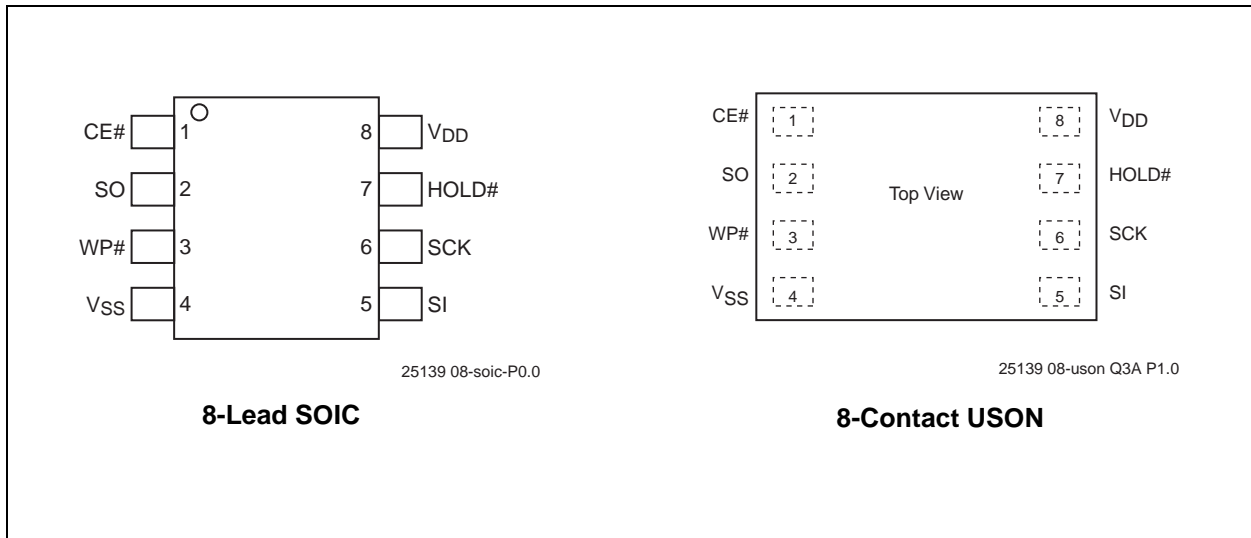

FIGURE 2-1: PIN ASSIGNMENTS

TABLE 2-1: PIN DESCRIPTION

Symbol	Pin Name	Functions
SCK	Serial Clock	To provide the input/output timing of the serial interface. Commands, addresses, or input data are latched on the rising edge of the clock input, while output data is shifted out on the falling edge of the clock input.
SI	Serial Data Input	To transfer commands, addresses, or data serially into the device. Inputs are latched on the rising edge of the serial clock.
SO	Serial Data Output	To transfer data serially out of the device. Data is shifted out on the falling edge of the serial clock.
CE#	Chip Enable	The device is enabled by a high to low transition on CE#. CE# must remain low for the duration of any command sequence. The device is deselected and placed in Standby mode when CE# is high.
WP#	Write Protect	The Write Protect (WP#) pin is used to enable/disable BPL bit in the status register.
HOLD#	Hold	To temporarily stop serial communication with SPI Flash memory while device is selected.
V _{DD}	Power Supply	To provide power supply voltage: 1.65-1.95V for SST25WF020A
V _{SS}	Ground	

3.0 MEMORY ORGANIZATION

The SST25WF020A SuperFlash memory arrays are organized in 64 uniform 4 KByte sectors, with four 64 KByte overlay erasable blocks.

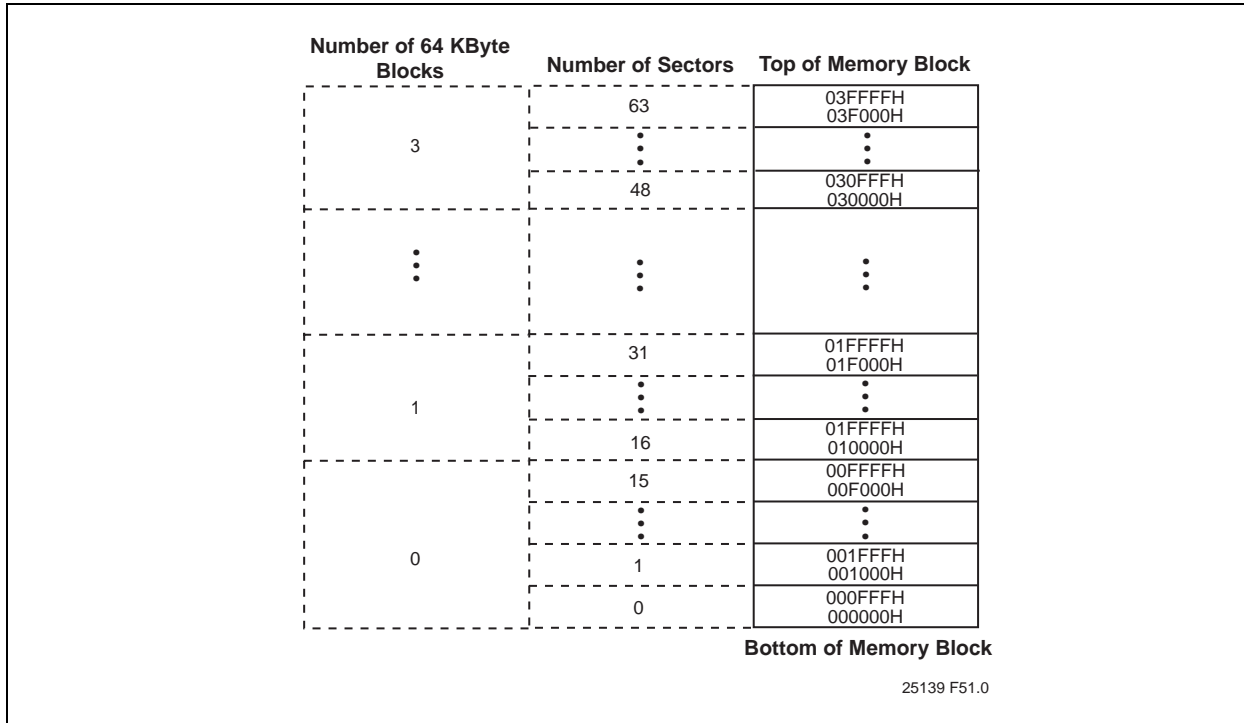

FIGURE 3-1: MEMORY MAP

4.0 DEVICE OPERATION

SST25WF020A is accessed through the SPI (Serial Peripheral Interface) bus compatible protocol. The SPI bus consist of four control lines; Chip Enable (CE#) is used to select the device, and data is accessed through the Serial Data Input (SI), Serial Data Output (SO), and Serial Clock (SCK).

The SST25WF020A supports both Mode 0 (0,0) and Mode 3 (1,1) of SPI bus operations. The difference between the two modes, as shown in Figure 4-1, is the state of the SCK signal when the bus master is in Stand-by mode and no data is being transferred. The SCK signal is low for Mode 0 and SCK signal is high for Mode 3. For both modes, the Serial Data In (SI) is sampled at the rising edge of the SCK clock signal and the Serial Data Output (SO) is driven after the falling edge of the SCK clock signal.

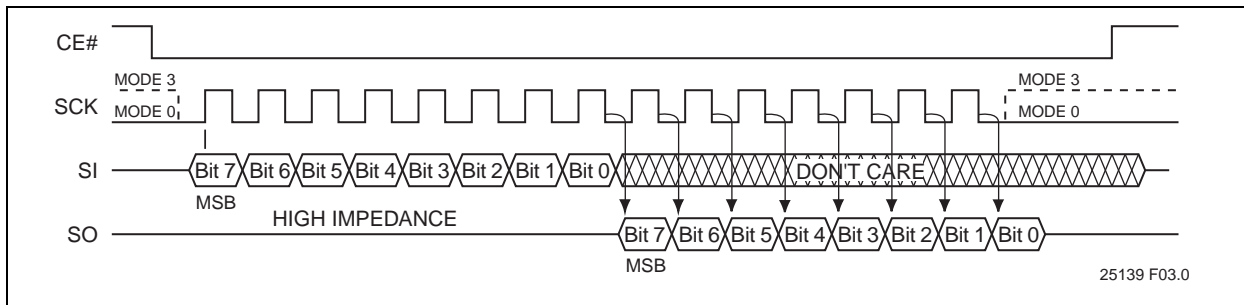

FIGURE 4-1: SPI PROTOCOL

4.0.1 HOLD

In the hold mode, serial sequences underway with the SPI Flash memory are paused without resetting the clocking sequence. To activate the HOLD# mode, CE# must be in active low state. The HOLD# mode begins when the SCK active low state coincides with the falling edge of the HOLD# signal. The Hold mode ends when the rising edge of the HOLD# signal coincides with the SCK active low state. HOLD# must not rise or fall when SCK logic level is high. See Figure 4-2 for Hold Condition waveform.

Once the device enters Hold mode, SO will be in high-impedance state while SI and SCK can be V_{IL} or V_{IH} .

If CE# is driven active high during a Hold condition, the device returns to standby mode. The device can then be re-initiated with the command sequences listed in Table 5-1. As long as HOLD# signal is low, the memory remains in the Hold condition. To resume communication with the device, HOLD# must be driven active high, and CE# must be driven active low. See Figure 4-2 for Hold timing.

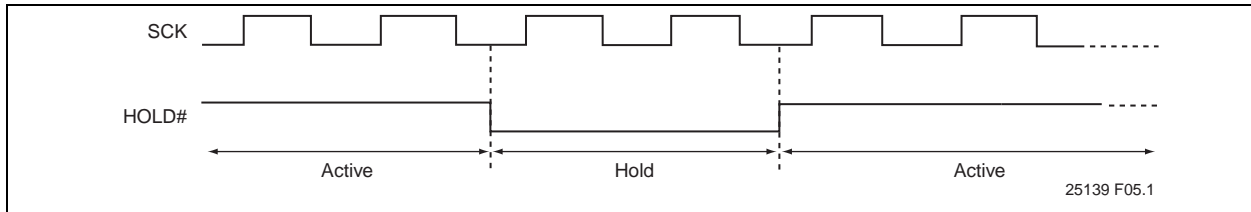

FIGURE 4-2: HOLD CONDITION WAVEFORM

4.1 Write Protection

SST25WF020A provides software Write protection. The Write Protect pin (WP#) enables or disables the lock-down function of the status register. The Block-Protection bits (BP0, BP1, TB, and BPL) in the status register

provide Write protection to the memory array and the status register. See Table 4-3 for the Block-Protection description.

4.1.1 WRITE PROTECT PIN (WP#)

The Write Protect (WP#) pin enables the lock-down function of the BPL bit (bit 7) in the status register. When WP# is driven low, the execution of the Write-

Status-Register (WRSR) instruction is determined by the value of the BPL bit (see Table 4-1). When WP# is high, the lock-down function of the BPL bit is disabled.

TABLE 4-1: CONDITIONS TO EXECUTE WRITE-STATUS-REGISTER (WRSR) INSTRUCTION

WP#	BPL	Execute WRSR Instruction
L	1	Not Allowed
L	0	Allowed
H	X	Allowed

4.2 Status Register

The software status register provides status on whether the flash memory array is available for any Read or Write operation, whether the device is Write enabled, and the state of the Memory Write protection.

During an internal Erase or Program operation, the status register may be read only to determine the completion of an operation in progress. Table 4-2 describes the function of each bit in the software status register.

TABLE 4-2: SOFTWARE STATUS REGISTER

Bit	Name	Function	Default at Power-up	Read/Write
0	BUSY	1 = Internal Write operation is in progress 0 = No internal Write operation is in progress	0	R
1	WEL	1 = Device is memory Write enabled 0 = Device is not memory Write enabled	0	R
2	BP0 ¹	Indicate current level of block write protection (See Table 4-3)	0 or 1	R/W
3	BP1 ¹	Indicate current level of block write protection (See Table 4-3)	0 or 1	R/W
4	RES	Reserved for future use	0	N/A
5	TB ¹	1 = 1/4 or 1/2 Bottom Memory Blocks are protected (See Table 4-3) 0 = 1/2 or 1/4 Top Memory Blocks are protected	0 or 1	R/W
6	RES	Reserved for future use	0	N/A
7	BPL ¹	1 = BP0, BP1, TB, and BPL are read-only bits 0 = BP0, BP1, TB, and BPL are read/writable	0 or 1	R/W

1. BP0, BP1, TB, and BPL bits are non-volatile memory bits.

4.2.1 BUSY (BIT 0)

The Busy bit determines whether there is an internal Erase or Program operation in progress. A '1' for the Busy bit indicates the device is busy with an operation in progress. A '0' indicates the device is ready for the next valid operation.

bits as long as WP# is high or the Block-Protect-Lock (BPL) bit is '0'. Chip-Erase can only be executed if Block-Protection bits are all '0'. BP0 and BP1 select the protected area and TB allocates the protected area to the higher-order address area (Top Blocks) or lower-order address area (Bottom Blocks).

4.2.2 WRITE ENABLE LATCH (WEL–BIT 1)

The Write-Enable-Latch bit indicates the status of the internal Write-Enable-Latch memory. If the WEL bit is set to '1', it indicates the device is Write enabled. If the bit is set to '0' (reset), it indicates the device is not Write enabled and does not accept any Write (Program/Erase) commands. The Write-Enable-Latch bit is automatically reset under the following conditions:

- Power-up
- Write-Disable (WRDI) instruction completion
- Page-Program instruction completion
- Sector-Erase instruction completion
- 64 KByte Block-Erase instruction completion
- Chip-Erase instruction completion
- Write-Status-Register instruction completion

4.2.3 BLOCK-PROTECTION (BP0, BP1, AND TB–BITS 2, 3, AND 5)

The Block-Protection (BP0, BP1, and TB) bits define the size of the memory area to be software protected against any memory Write (Program or Erase) operation, see Table 4-3. The Write-Status-Register (WRSR) instruction is used to program the BP0, BP1, and TB

4.2.4 BLOCK PROTECTION LOCK-DOWN (BPL-BIT 7)

BP1, TB, and BPL bits. When the WP# pin is driven high (V_{IH}), the BPL bit has no effect and its value is 'Don't Care'.

When the WP# pin is driven low (V_{IL}), it enables the Block-Protection-Lock-Down (BPL) bit. When BPL is set to '1', it prevents any further alteration of the BP0,

TABLE 4-3: SOFTWARE STATUS REGISTER BLOCK PROTECTION

Protection Level	Status Register Bit			Protected Memory Address
	TB	BP1	BP0	
0 (Full Memory Array unprotected)	X	0	0	None
T1 (1/4 Top Memory Block protected)	0	0	1	030000H-03FFFFH
T2 (1/2 Top Memory Block protected)	0	1	0	020000H-03FFFFH
B1 (1/4 Bottom Memory Block protected)	1	0	1	000000H-00FFFFH
B2 (1/2 Bottom Memory Block protected)	1	1	0	000000H-01FFFFH
3 (Full Memory Array protected)	X	1	1	000000H-03FFFFH

5.0 INSTRUCTIONS

Instructions are used to read, write (Erase and Program), and configure the SST25WF020A devices. The instruction bus cycles are 8 bits each for commands (Op Code), data, and addresses. The Write-Enable (WREN) instruction must be executed prior to Sector-Erase, Block-Erase, Page-Program, Write-Status-Register, or Chip-Erase instructions. The complete instructions are provided in Table 5-1. All instructions are synchronized off a high-to-low transition of CE#. Inputs will be accepted on the rising edge of SCK starting with

the most significant bit. CE# must be driven low before an instruction is entered and must be driven high after the last bit of the instruction has been shifted in (except for Read, Read-ID, and Read-Status-Register instructions). Any low-to-high transition on CE#, before receiving the last bit of an instruction bus cycle, will terminate the instruction in progress and return the device to standby mode. Instruction commands (Op Code), addresses, and data are all input from the most significant bit (MSB) first.

TABLE 5-1: DEVICE OPERATION INSTRUCTIONS

Instruction	Description	Op Code Cycle ¹	Address Cycle(s) ²	Dummy Cycle(s)	Data Cycle(s)	Maximum Frequency
Read	Read Memory	0000 0011b (03H)	3	0	1 to ∞	25 MHz
High-Speed Read	Read Memory at Higher Speed	0000 1011b (0BH)	3	1	1 to ∞	40 MHz
4 KByte Sector-Erase ³	Erase 4 KByte of memory array	0010 0000b (20H) 1101 0111b (D7H)	3	0	0	
64 KByte Block-Erase ⁴	Erase 64 KByte block of memory array	1101 1000b (D8H)	3	0	0	
Chip-Erase	Erase Full Memory Array	0110 0000b (60H) or 1100 0111b (C7H)	0	0	0	
Page-Program	To program up to 256 Bytes	0000 0010b (02H)	3	0	1 to 256	
RDSR ⁵	Read-Status-Register	0000 0101b (05H)	0	0	1 to ∞	
WRSR	Write-Status-Register	0000 0001b (01H)	0	0	1	
WREN	Write-Enable	0000 0110b (06H)	0	0	0	
WRDI	Write-Disable	0000 0100b (04H)	0	0	0	
RDID ^{6, 7}	Read-ID	1010 1011b (ABH)	3	0	1 to ∞	
JEDEC-ID	JEDEC ID Read	1001 1111b (9FH)	0	0	4 to ∞	
DPD	Deep Power-Down Mode	1011 1001b (B9H)	0	0	0	
RDPD ⁷	Release from Deep Power-Down or Read ID	1010 1011b (ABH)	0	0	0	

- One bus cycle is eight clock periods.
- Address bits above the most significant bit of each density can be V_{IL} or V_{IH} .
- 4 KByte Sector-Erase addresses: use $A_{MS}-A_{12}$, remaining addresses are don't care but must be set either at V_{IL} or V_{IH} .
- 64 KByte Block-Erase addresses: use $A_{MS}-A_{16}$, remaining addresses are don't care but must be set either at V_{IL} or V_{IH} .
- The Read-Status-Register is continuous with ongoing clock cycles until terminated by a low to high transition on CE#.
- Device ID is read after three dummy address bytes. The Device ID output stream is continuous until terminated by a low-to-high transition on CE#.
- The instructions Release from Deep Power down and Read-ID are similar instructions (ABH). Executing Read-ID requires the ABH instruction, followed by 24 dummy address bits to retrieve the Device ID. Release from Deep Power-Down only requires the instruction ABH.

5.1 Read (25 MHz)

The Read instruction, 03H, supports up to 25 MHz Read. The device outputs a data stream starting from the specified address location. The data stream is continuous through all addresses until terminated by a low-to-high transition on CE#. The internal address pointer automatically increments until the highest memory address is reached. Once the highest memory address is reached, the address pointer automatically incre-

ments to the beginning (wrap-around) of the address space. For example, for 2 Mbit density, once the data from the address location 3FFFFH is read, the next output is from address location 000000H. The Read instruction is initiated by executing an 8-bit command, 03H, followed by address bits $A_{23}-A_0$. CE# must remain active low for the duration of the Read cycle. See Figure 5-1 for the Read sequence.

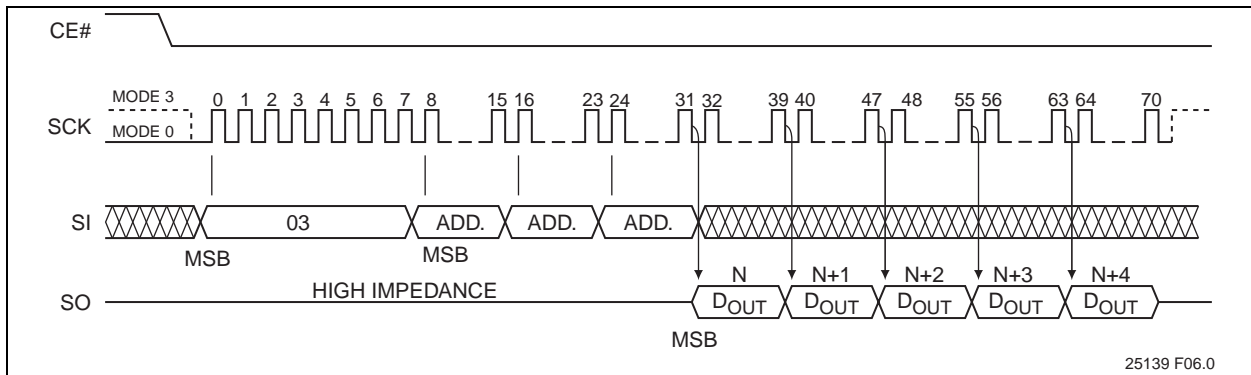

FIGURE 5-1: READ SEQUENCE

5.2 High-Speed-Read (40 MHz)

The High-Speed-Read instruction supporting up to 40 MHz Read is initiated by executing an 8-bit command, 0BH, followed by address bits $[A_{23}-A_0]$ and a dummy byte. CE# must remain active low for the duration of the High-Speed-Read cycle. See Figure 5-2 for the High-Speed-Read sequence.

through all addresses until terminated by a low-to-high transition on CE#. The internal address pointer will automatically increment until the highest memory address is reached. Once the highest memory address is reached, the address pointer will automatically increment to the beginning (wrap-around) of the address space. For example, for 2 Mbit density, once the data from address location 3FFFFH is read, the next output will be from address location 000000H.

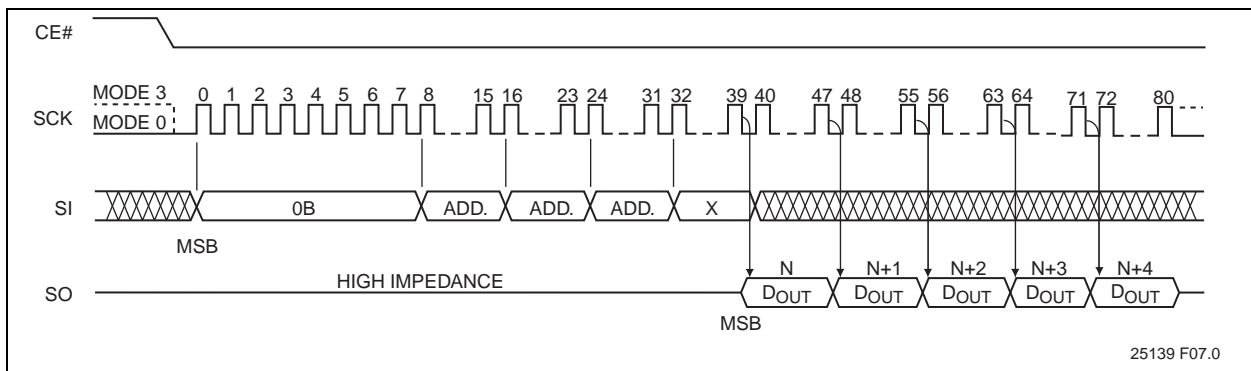

FIGURE 5-2: HIGH-SPEED-READ SEQUENCE

5.3 Page-Program

The Page-Program instruction programs up to 256 Bytes of data in the memory. The data for the selected page address must be in the erased state (FFH) before initiating the Page-Program operation. A Page-Program applied to a protected memory area will be ignored. Prior to the program operation, execute the WREN instruction.

To execute a Page-Program operation, the host drives CE# low, then sends the Page-Program command cycle (02H), three address cycles, followed by the data to be programmed, and then drives CE# high. The programmed data must be between 1 to 256 Bytes and in whole byte increments; sending less than a full byte will cause the partial byte to be ignored. Poll the BUSY bit in the Status register, or wait T_{PP} , for the completion of

the internal, self-timed, Page-Program operation. See [Figure 5-3](#) for the Page-Program sequence and [Figure 6-8](#) for the Page-Program flow chart.

When executing Page-Program, the memory range for the SST25WF020A is divided into 256-Byte page boundaries. The device handles the shifting of more than 256 Bytes of data by maintaining the last 256 Bytes as the correct data to be programmed. If the target address for the Page-Program instruction is not the beginning of the page boundary (A[7:0] are not all zero), and the number of bytes of data input exceeds or overlaps the end of the address of the page boundary, the excess data inputs wrap around and will be programmed at the start of that target page.

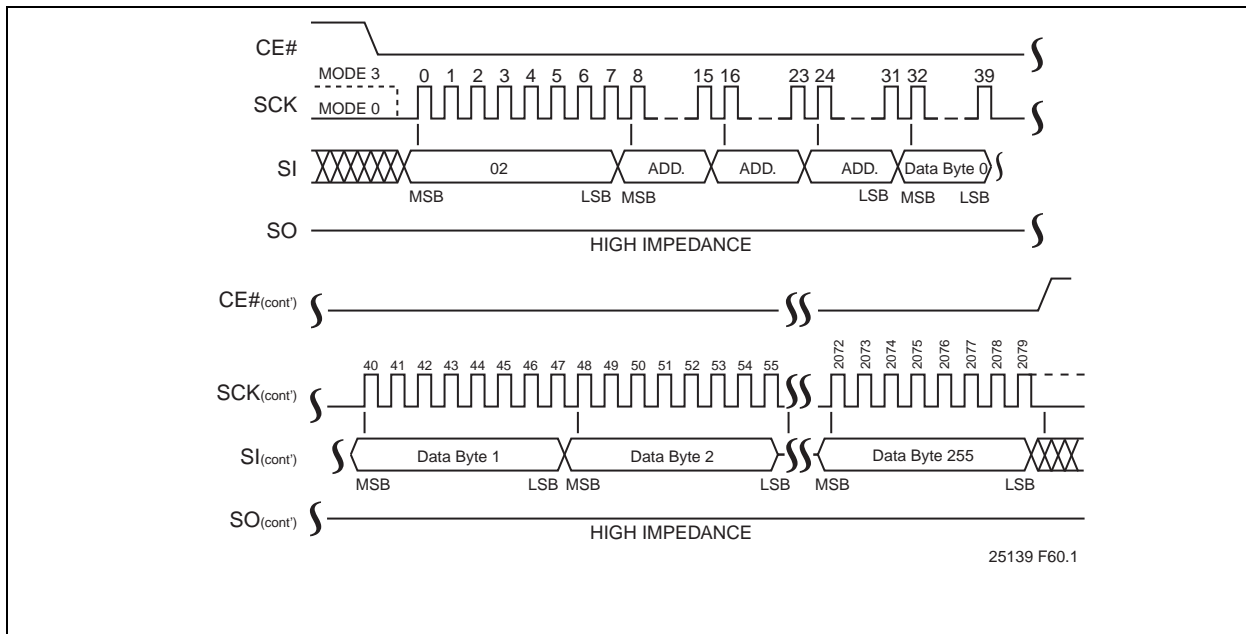

FIGURE 5-3: PAGE-PROGRAM SEQUENCE

5.4 Sector-Erase

The Sector-Erase instruction clears all bits in the selected 4 KByte sector to FFH. A Sector-Erase instruction applied to a protected memory area will be ignored. Prior to any Write operation, the Write-Enable (WREN) instruction must be executed. CE# must remain active low for the duration of any command sequence. The Sector-Erase instruction is initiated by executing an 8-bit command, 20H or D7H, followed by address bits [A₂₃-A₀]. Address bits [A_{MS}-A₁₂]

(A_{MS} = Most Significant address) are used to determine the sector address (SA_X), remaining address bits can be V_{IL} or V_{IH}. CE# must be driven high before the instruction is executed. Poll the BUSY bit in the Software Status register, or wait T_{SE}, for the completion of the internal self-timed Sector-Erase cycle. See Figure 5-4 for the Sector-Erase sequence and Figure 6-9 for the flow chart.

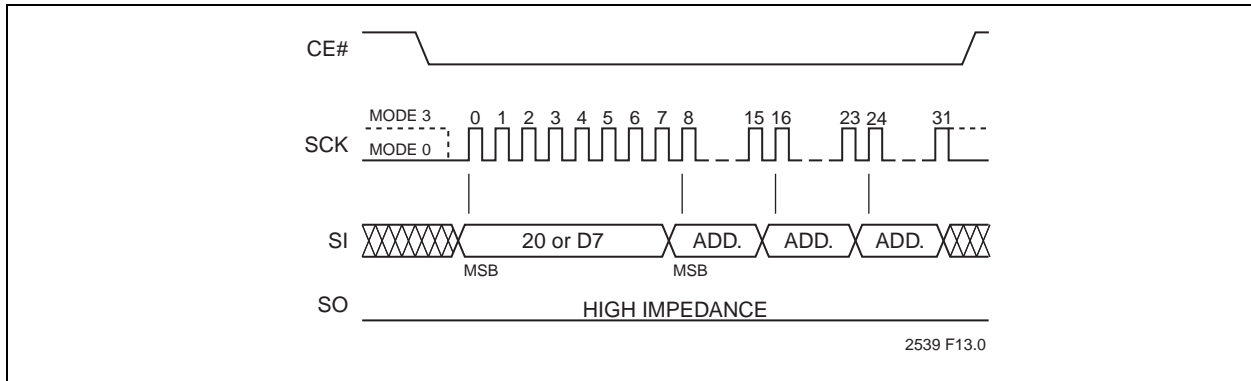

FIGURE 5-4: SECTOR-ERASE SEQUENCE

5.5 64-KByte Block-Erase

The 64-KByte Block-Erase instruction clears all bits in the selected 64 KByte block to FFH. Applying this instruction to a protected memory area results in the instruction being ignored. Prior to any Write operation, the Write-Enable (WREN) instruction must be executed. CE# must remain active low for the duration of any command sequence.

[A₂₃-A₀]. Address bits [A_{MS}-A₁₆] (A_{MS} = Most Significant Address) determine the block address (BA_X), remaining address bits can be V_{IL} or V_{IH}. CE# must be driven high before executing the instruction. Poll the Busy bit in the software status register or wait T_{BE} for the completion of the internal self-timed Block-Erase cycle. See Figure 5-5 for the 64-KByte Block-Erase sequences and Figure 6-9 for the flow chart.

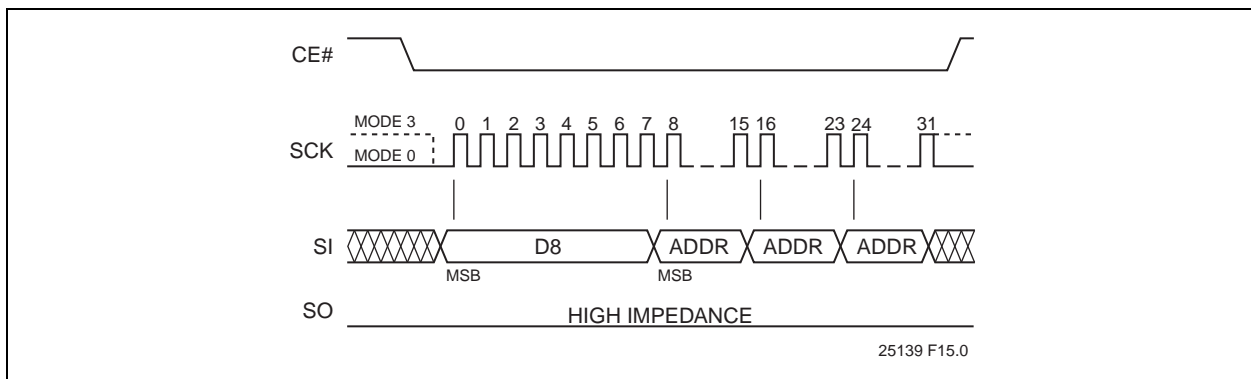

FIGURE 5-5: 64-KBYTE BLOCK-ERASE SEQUENCE

5.6 Chip-Erase

The Chip-Erase instruction clears all bits in the device to FFH. A Chip-Erase instruction is ignored if any of the memory area is protected. Prior to any Write operation, the Write-Enable (WREN) instruction must be executed. CE# must remain active low for the duration of the Chip-Erase instruction sequence. Initiate the Chip-

Erase instruction by executing an 8-bit command, 60H or C7H. CE# must be driven high before the instruction is executed. Poll the BUSY bit in the Software Status register, or wait T_{CE} , for the completion of the internal self-timed Chip-Erase cycle. See Figure 5-6 for the Chip-Erase sequence and Figure 6-10 for the flow chart.

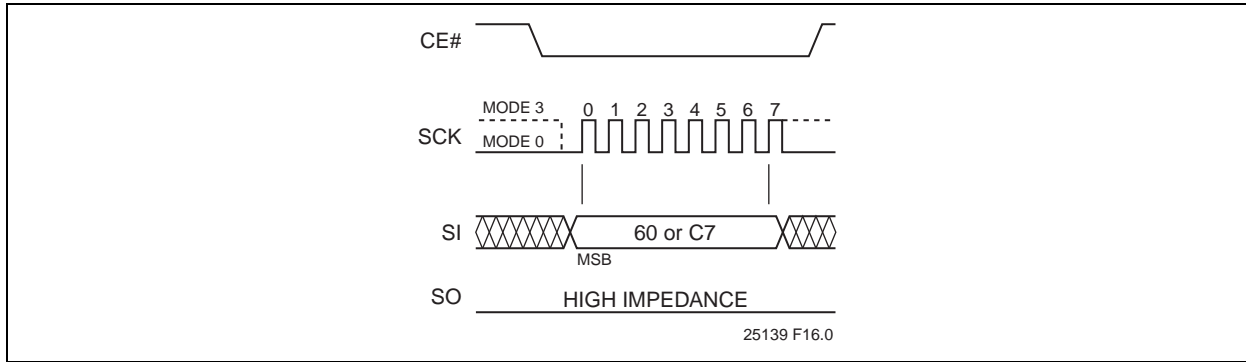

FIGURE 5-6: CHIP-ERASE SEQUENCE

5.7 Read-Status-Register (RDSR)

The Read-Status-Register (RDSR) instruction, 05H, allows reading of the status register. The status register may be read at any time even during a Write (Program/Erase) operation. When a Write operation is in progress, the Busy bit may be checked before sending any new commands to assure that the new commands are

properly received by the device. CE# must be driven low before the RDSR instruction is entered and remain low until the status data is read. Read-Status-Register is continuous with ongoing clock cycles until it is terminated by a low to high transition of the CE#. See Figure 5-7 for the RDSR instruction sequence.

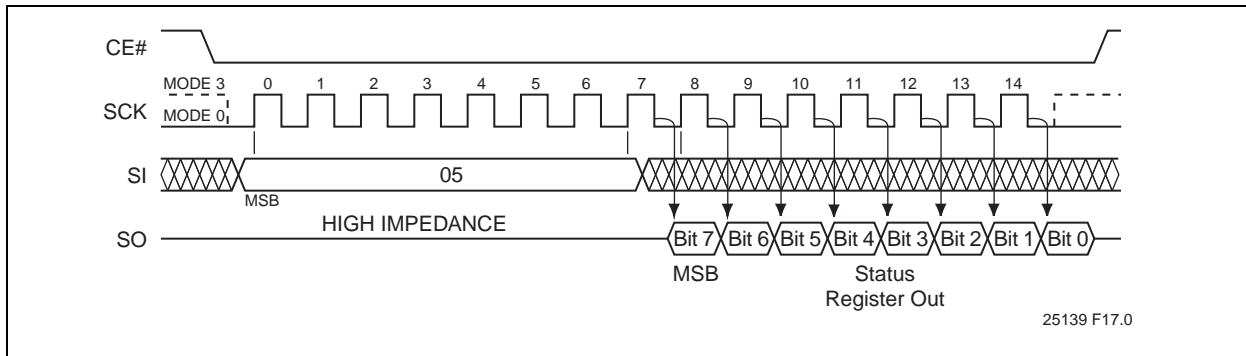

FIGURE 5-7: READ-STATUS-REGISTER (RDSR) SEQUENCE

5.8 Write-Enable (WREN)

The Write-Enable (WREN) instruction, 06H, sets the Write-Enable-Latch bit in the Status Register to 1 allowing Write operations to occur. The WREN instruction must be executed prior to any Write (Program/Erase) operation. The WREN instruction may also be used to allow execution of the Write-Status-Register (WRSR)

instruction; however, the Write-Enable-Latch bit in the Status Register will be cleared upon the rising edge CE# of the WRSR instruction. CE# must be driven low before entering the WREN instruction, and CE# must be driven high before executing the WREN instruction. See [Figure 5-8](#) for the WREN instruction sequence.

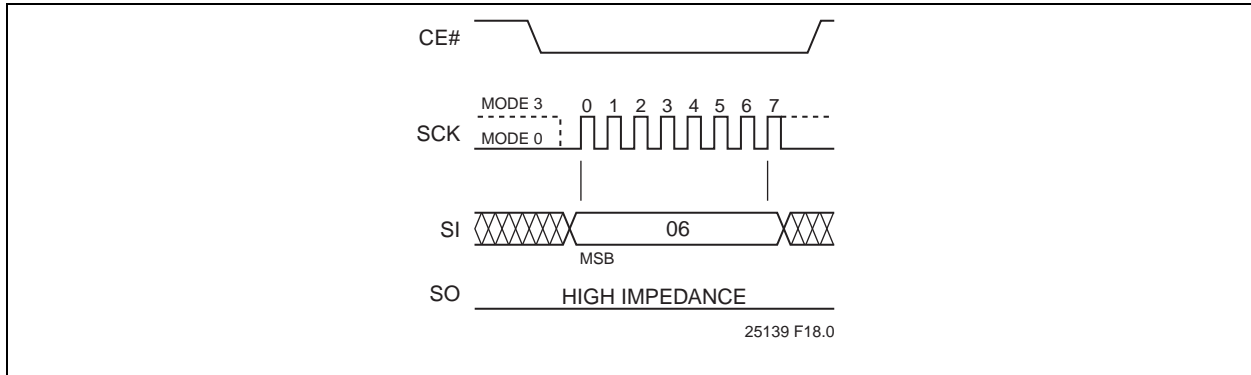

FIGURE 5-8: WRITE ENABLE (WREN) SEQUENCE

5.9 Write-Disable (WRDI)

The Write-Disable (WRDI) instruction, 04H, resets the Write-Enable-Latch bit to '0', thus preventing any new Write operations. CE# must be driven low before enter-

ing the WRDI instruction, and CE# must be driven high before executing the WRDI instruction. See [Figure 5-11](#) for the WRDI instruction sequence.

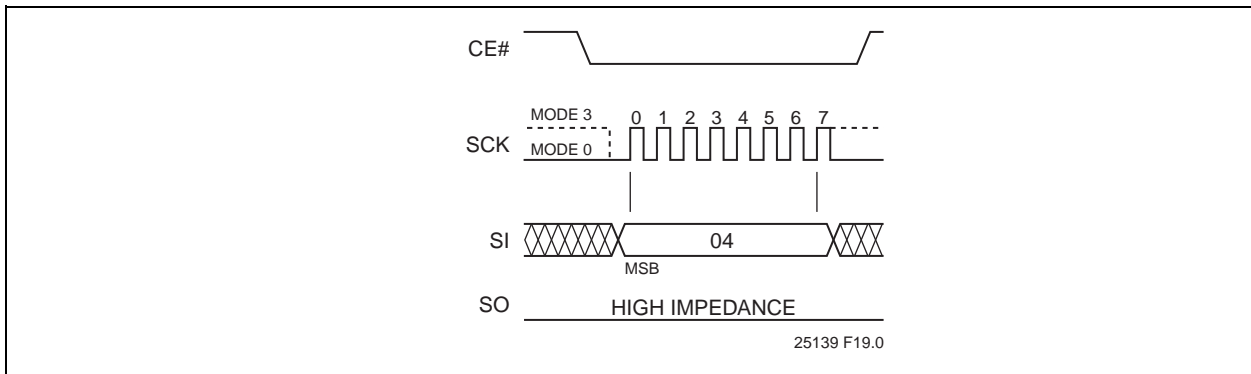

FIGURE 5-9: WRITE DISABLE (WRDI) SEQUENCE

5.10 Write-Status-Register (WRSR)

The Write-Status-Register instruction writes new values to the BP0, BP1, TB, and BPL bits of the status register. CE# must be driven low before the command sequence of the WRSR instruction is entered and driven high before the WRSR instruction is executed. Poll the BUSY bit in the Software Status register, or wait T_{WRSR} , for the completion of the internal self-timed Write-Status-Register cycle. See Figure 5-10 for WREN and WRSR instruction sequences and Figure 6-11 for the WRSR flow chart.

Executing the Write-Status-Register instruction will be ignored when WP# is low and BPL bit is set to '1'. When the WP# is low, the BPL bit can only be set from '0' to

'1' to lock-down the status register, but cannot be reset from '1' to '0'. When WP# is high, the lock-down function of the BPL bit is disabled and the BPL, BP0, BP1, and TB bits in the status register can all be changed. As long as BPL bit is set to '0' or WP# pin is driven high (V_{IH}) prior to the low-to-high transition of the CE# pin at the end of the WRSR instruction, the bits in the status register can all be altered by the WRSR instruction. In this case, a single WRSR instruction can set the BPL bit to '1' to lock down the status register as well as altering the BP0, BP1, and TB bits at the same time. See Table 4-1 for a summary description of WP# and BPL functions.

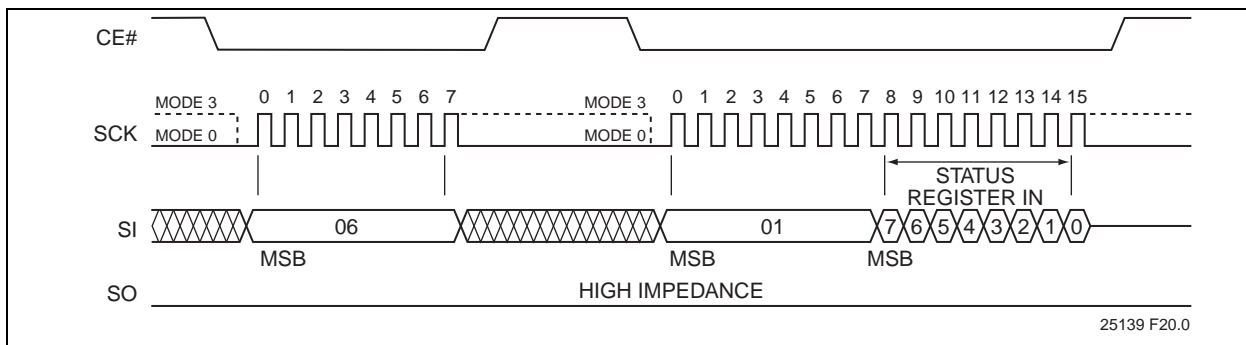

FIGURE 5-10: WRITE-ENABLE (WREN) AND WRITE-STATUS-REGISTER (WRSR) SEQUENCE

5.11 Power-Down

The Deep Power-Down (DPD) instruction puts the device in the lowest power consumption mode – the Deep Power-Down mode. This instruction is ignored if the device is busy with an internal write operation. While the device is in DPD mode, all instructions are ignored except for the Release Deep Power-Down instruction or Read ID.

To initiate deep power-down, input the Deep Power-Down instruction (B9H) while driving CE# low. CE# must be driven high before executing the DPD instruction. After driving CE# high, it requires a delay of T_{DPD}

before the standby current I_{SB} is reduced to the deep power-down current I_{DPD} . See Figure 5-11 for the DPD instruction sequence.

Exit the power-down state using the Release from Deep Power-Down or Read ID instruction. CE# must be driven low before sending the Release from Deep Power-Down command cycle (ABH), and then driving CE# high. The device will return to Standby mode and be ready for the next instruction after T_{SBR} . See Figure 5-12. for the Release from Deep Power-Down sequence.

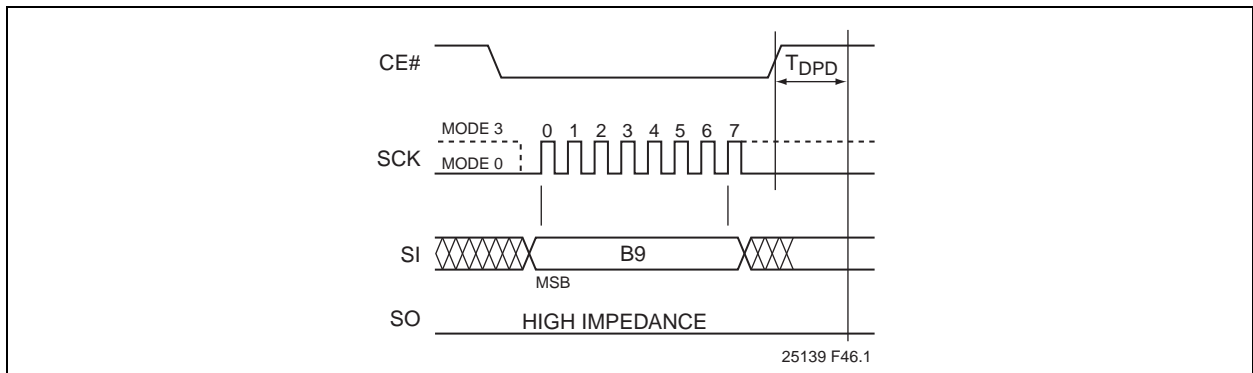

FIGURE 5-11: DEEP POWER-DOWN SEQUENCE

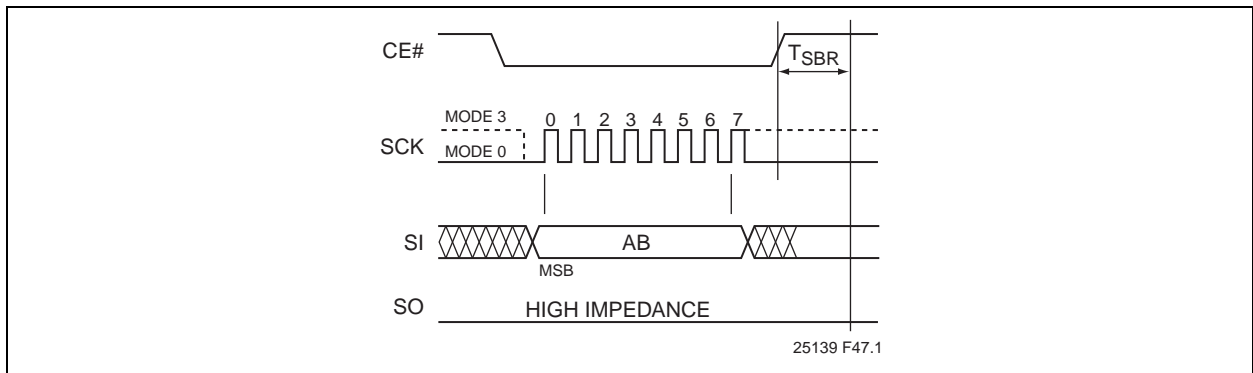

FIGURE 5-12: RELEASE FROM DEEP POWER-DOWN SEQUENCE

5.12 Read-ID

The Read-ID instruction identifies the device as SST25WF020A. Use the Read-ID instruction to identify SST25WF020A when using multiple manufacturers in the same socket. See [Table 5-2](#).

The device ID information is read by executing an 8-bit

command, ABH, followed by 24 dummy address bits. Following the Read-ID instruction, and 24 address dummy bits, the device ID continues to output with continuous clock input until terminated by a low-to-high transition on CE#.

TABLE 5-2: PRODUCT IDENTIFICATION

	Address	Data
SST25WF020A ID	XXXXXXH	34H

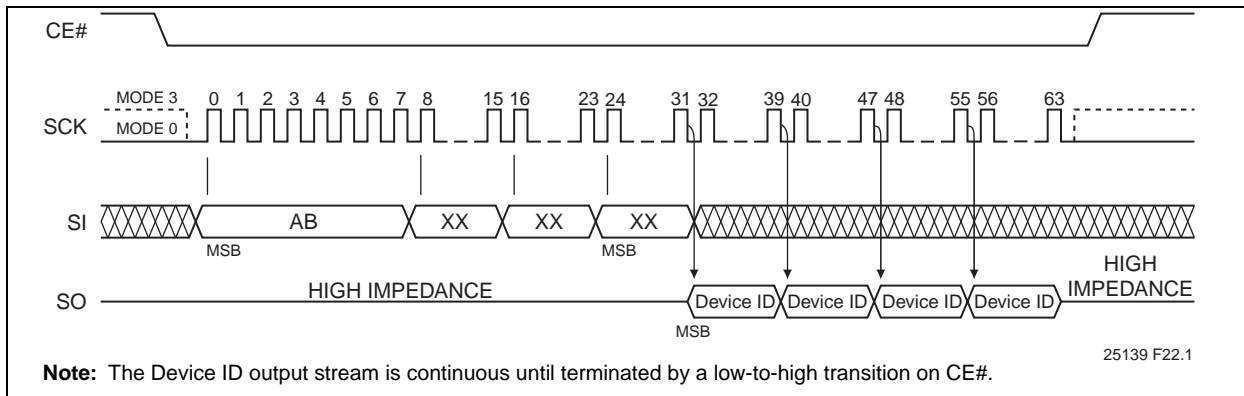

FIGURE 5-13: READ-ID SEQUENCE

5.13 JEDEC Read-ID

The JEDEC Read-ID instruction identifies the device ID information of SST25WF020A. The device information can be read by executing the 8-bit command, 9FH. Following the JEDEC Read-ID instruction, a 32bit device ID information is output from the device. The Device ID information is assigned by the manufacturer and contains the Device ID 1 in the first byte, the type of mem-

ory in the second byte, the memory capacity of the device in the third byte, and a reserved code in the fourth byte. The 4-Byte code outputs repeatedly with continuous clock input until a low-to-high transition on CE#. See [Figure 5-14](#) for the instruction sequence. The JEDEC Read ID instruction is terminated by a low to high transition on CE# at any time during data output.

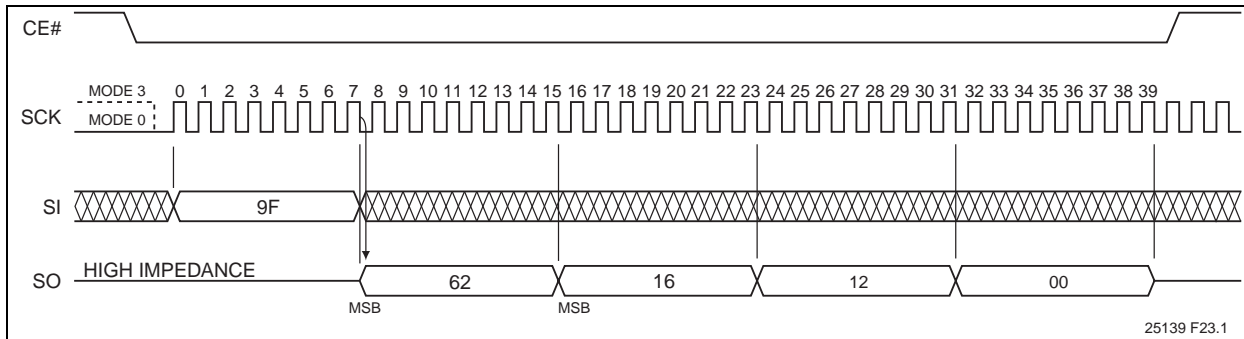

FIGURE 5-14: JEDEC READ-ID SEQUENCE

TABLE 5-3: JEDEC READ-ID DATA-OUT

Product	Device ID			
	Device ID 1 (Byte 1)	Memory Type (Byte 2)	Memory Capacity (Byte 3)	Reserved Code (Byte 4)
SST25WF020A	62H	16H	12H	00H

6.0 ELECTRICAL SPECIFICATIONS

Absolute Maximum Stress Ratings (Applied conditions greater than those listed under “Absolute Maximum Stress Ratings” may cause permanent damage to the device. This is a stress rating only and functional operation of the device at these conditions or conditions greater than those defined in the operational sections of this data sheet is not implied. Exposure to absolute maximum stress rating conditions may affect device reliability.)

Temperature Under Bias	-55°C to +125°C
Storage Temperature	-55°C to +150°C
D. C. Voltage on Any Pin to Ground Potential	-0.5V to $V_{DD}+0.5V$
Transient Voltage (<20 ns) on Any Pin to Ground Potential	-2.0V to $V_{DD}+2.0V$
Package Power Dissipation Capability ($T_A = 25^\circ C$)	1.0W
Surface Mount Solder Reflow Temperature	260°C for 10 seconds
Output Short Circuit Current ¹	50 mA

1. Output shorted for no more than one second. No more than one output shorted at a time.

TABLE 6-1: OPERATING RANGE

Range	Ambient Temp	V_{DD}
Industrial	-40°C to +85°C	1.65-1.95V

TABLE 6-2: AC CONDITIONS OF TEST

Input Rise/Fall Time	Output Load
5ns	$C_L = 30 \text{ pF}$

6.1 Power-Up Specifications

All functionalities and DC specifications are specified for a V_{DD} ramp rate of greater than 1V per 100 ms (0V to 1.8V in less than 180 ms). See Table 6-3 and Figure 6-2 for more information.

TABLE 6-3: RECOMMENDED SYSTEM POWER-UP TIMINGS

Symbol	Parameter	Minimum	Units
$T_{PU-READ}^1$	V_{DD} Min to Read Operation	100	μs
$T_{PU-WRITE}^1$	V_{DD} Min to Write Operation	100	μs

1. This parameter is measured only for initial qualification and after a design or process change that could affect this parameter.

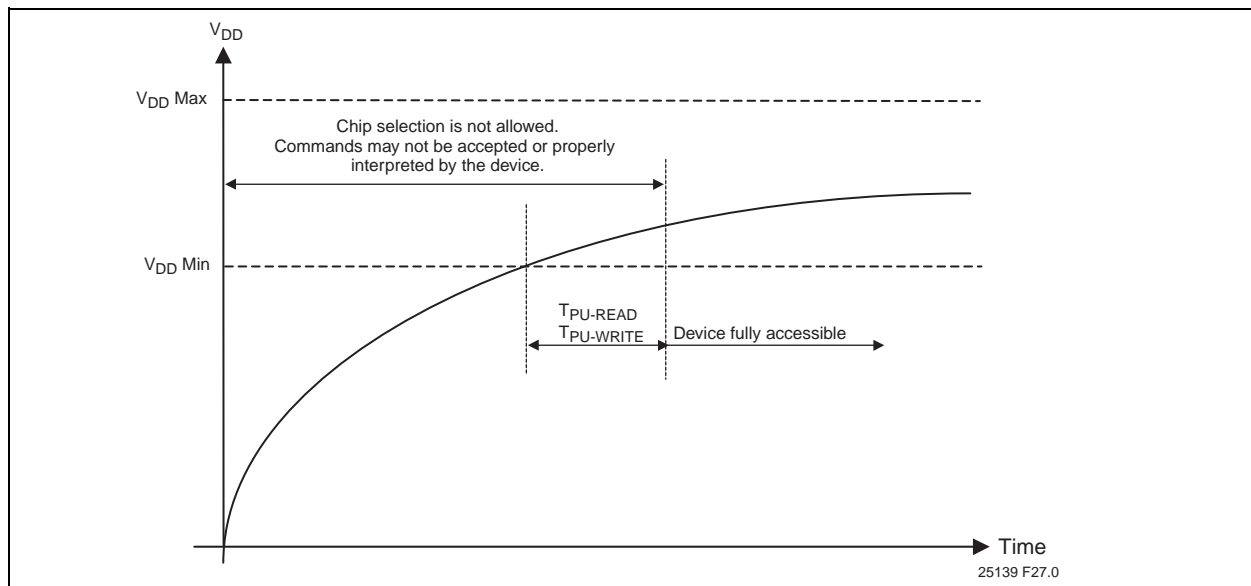

FIGURE 6-1: POWER-UP TIMING DIAGRAM

6.2 Hardware Data Protection

SST25WF020A provides a power-up reset function. To ensure that the power reset circuit will operate correctly, the device must meet the conditions shown in

Figure 6-2 and Table 6-4. Microchip does not guarantee the data in the event of an instantaneous power failure that occurs during a Write operation.

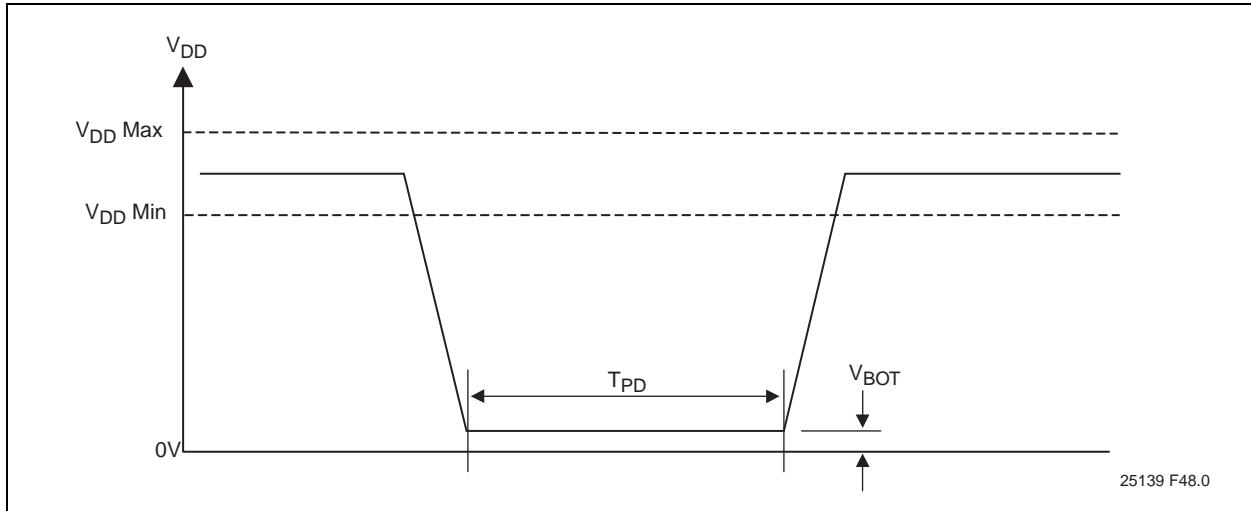

FIGURE 6-2: POWER-DOWN TIMING DIAGRAM

TABLE 6-4: RECOMMENDED SYSTEM POWER-DOWN TIMINGS

Symbol	Parameter	Min	Max	Units
T_{PD}	Power-down time	10		ms
V_{BOT}	Power-down voltage		0.2	V

6.3 Software Data Protection

SST25WF020A prevents unintentional operations by not recognizing commands under the following conditions:

- After inputting a Write command, if the rising CE# edge timing is not in a bus cycle (8 CLK units of SCK)
- When the Page-Program data is not in 1-byte increments
- If the Write Status Register instruction is input for two bus cycles or more.

6.4 Decoupling Capacitor

A 0.1 μ F ceramic capacitor must be provided to each device and connected between V_{DD} and V_{SS} to ensure that the device will operate correctly.

6.5 DC Characteristics

TABLE 6-5: DC OPERATING CHARACTERISTICS

Symbol	Parameter	Limits				Test Conditions
		Min	Typ ¹	Max	Units	
I _{DDR}	Read Current			6	mA	CE#=0.1 V _{DD} /0.9 V _{DD} @25 MHz, SO=open
I _{DDR2}	Read Current			8	mA	CE#=0.1 V _{DD} /0.9V _{DD} @40 MHz, SO=open
I _{DDW}	Program and Erase Current			15	mA	CE#=V _{DD}
I _{SB}	Standby Current			50	μA	CE#=V _{DD} , V _{IN} =V _{DD} or V _{SS}
I _{DPD}	Deep Power-Down			10	μA	CE#=V _{DD} , V _{IN} =V _{DD} or V _{SS}
I _{LI}	Input Leakage Current			2	μA	V _{IN} =GND to V _{DD} , V _{DD} =V _{DD} Max
I _{LO}	Output Leakage Current			2	μA	V _{OUT} =GND to V _{DD} , V _{DD} =V _{DD} Max
V _{IL}	Input Low Voltage	-0.3		0.3	V	V _{DD} =V _{DD} Min
V _{IH}	Input High Voltage	0.7 V _{DD}		V _{DD} +0.3	V	V _{DD} =V _{DD} Max
V _{OL}	Output Low Voltage			0.2	V	I _{OL} =100 μA, V _{DD} =V _{DD} Min
V _{OH}	Output High Voltage	V _{DD} -0.2			V	I _{OH} =-100 μA, V _{DD} =V _{DD} Min

1. Value characterized, not fully tested in production.

TABLE 6-6: CAPACITANCE (T_A = 25°C, F=1 MHZ, OTHER PINS OPEN)

Parameter	Description	Test Condition	Maximum
C _{OUT} ¹	Output Pin Capacitance	V _{OUT} = 0V	12 pF
C _{IN} ¹	Input Capacitance	V _{IN} = 0V	6 pF

1. This parameter is measured only for initial qualification and after a design or process change that could affect this parameter.

TABLE 6-7: RELIABILITY CHARACTERISTICS

Symbol	Parameter	Minimum Specification	Units	Test Method
N _{END} ¹	Endurance	100,000	Cycles	JEDEC Standard A117
	Status Register Write Cycle	100,000	Cycles	JEDEC Standard A117
T _{DR} ¹	Data Retention	20	Years	JEDEC Standard A103
I _{LTH} ¹	Latch Up	100 + I _{DD}	mA	JEDEC Standard 78

1. This parameter is measured only for initial qualification and after a design or process change that could affect this parameter.

6.6 AC Characteristics

TABLE 6-8: AC OPERATING CHARACTERISTICS

Symbol	Parameter	Limits - 25 MHz			Limits - 40 MHz			Units
		Min	Typ	Max	Min	Typ	Max	
F _{CLK} ¹	Serial Clock Frequency			25			40	MHz
T _{SCKH}	Serial Clock High Time	14			11.5			ns
T _{SCKL}	Serial Clock Low Time	14			11.5			ns
T _{SCKR}	Serial Clock Rise Time			5			5	ns
T _{SCKF}	Serial Clock Fall Time			5			5	ns
T _{CES} ²	CE# Active Setup Time	10			10			ns
T _{CEH} ²	CE# Active Hold Time	10			10			ns
T _{CHS} ²	CE# Not Active Setup Time	10			10			ns
T _{CHH} ²	CE# Not Active Hold Time	10			10			ns
T _{CPH}	CE# High Time	25			25			ns
T _{CHZ}	CE# High to High-Z Output			15			15	ns
T _{CLZ}	SCK Low to Low-Z Output	0			0			ns
T _{DS}	Data In Setup Time	5			5			ns
T _{DH}	Data In Hold Time	5			5			ns
T _{HLS}	HOLD# Low Setup Time	5			5			ns
T _{HHS}	HOLD# High Setup Time	5			5			ns
T _{HLH}	HOLD# Low Hold Time	5			5			ns
T _{HHH}	HOLD# High Hold Time	5			5			ns
T _{HZ}	HOLD# Low to High-Z Output			9			9	ns
T _{LZ}	HOLD# High to Low-Z Output			12			12	ns
T _{OH}	Output Hold from SCK Change	1			1			ns
T _V	Output Valid from SCK		8	11		8	11	ns
T _{WPS}	WP# Setup Time	20			20			ns
T _{WPH}	WP# Hold Time	20			20			ns
T _{WRSR}	Status Register Write Time			10			10	ms
T _{DPD}	CE# High to Deep Power-Down			5			5	μs
T _{SBR}	Deep Power-Down (CE# High) to Standby Mode			5			5	μs
T _{SE}	Sector-Erase		40	150		40	150	ms
T _{BE}	Block-Erase		80	250		80	250	ms
T _{CE}	Chip-Erase		0.3	3		0.3	3	s
T _{PP}	Page-Program (256 Byte)		3.0	3.5		3.0	3.5	ms
	n Byte		n byte 0.15 + n*2.85/ 256	0.20 + n*3.30/ 256		n byte 0.15 + n*2.85/ 256	0.20 + n*3.30/ 256	ms

1. Maximum clock frequency for Read instruction, 03H, is 25 MHz
2. Relative to SCK

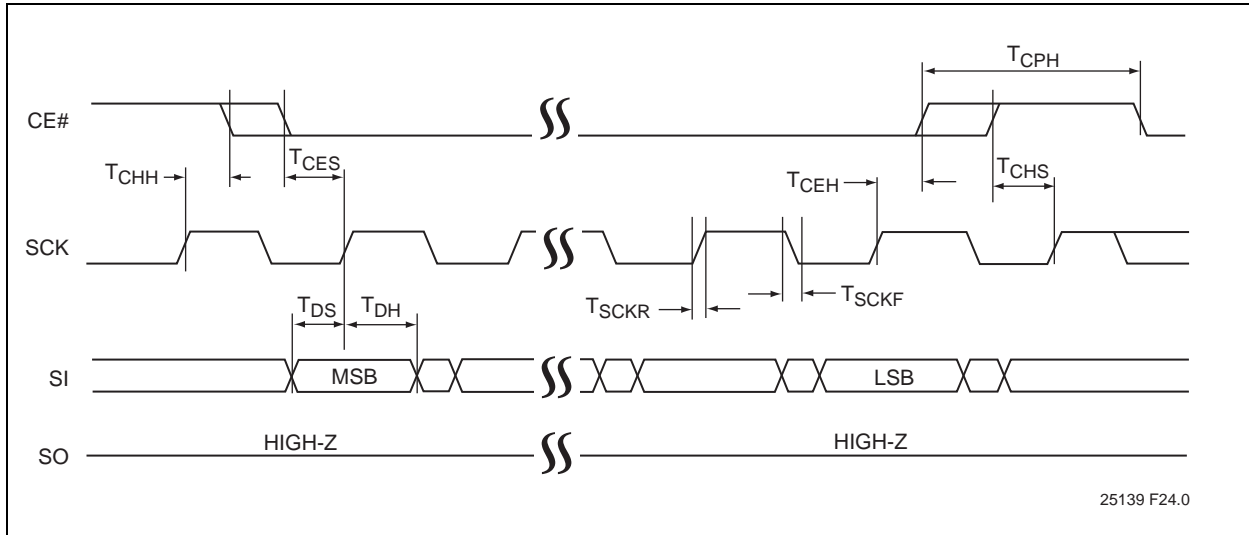

FIGURE 6-3: SERIAL INPUT TIMING DIAGRAM

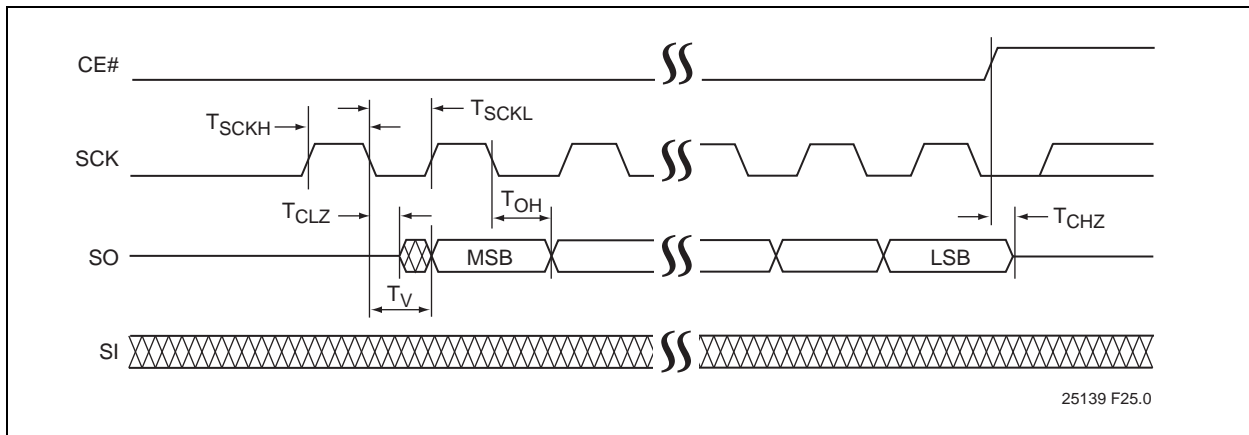

FIGURE 6-4: SERIAL OUTPUT TIMING DIAGRAM

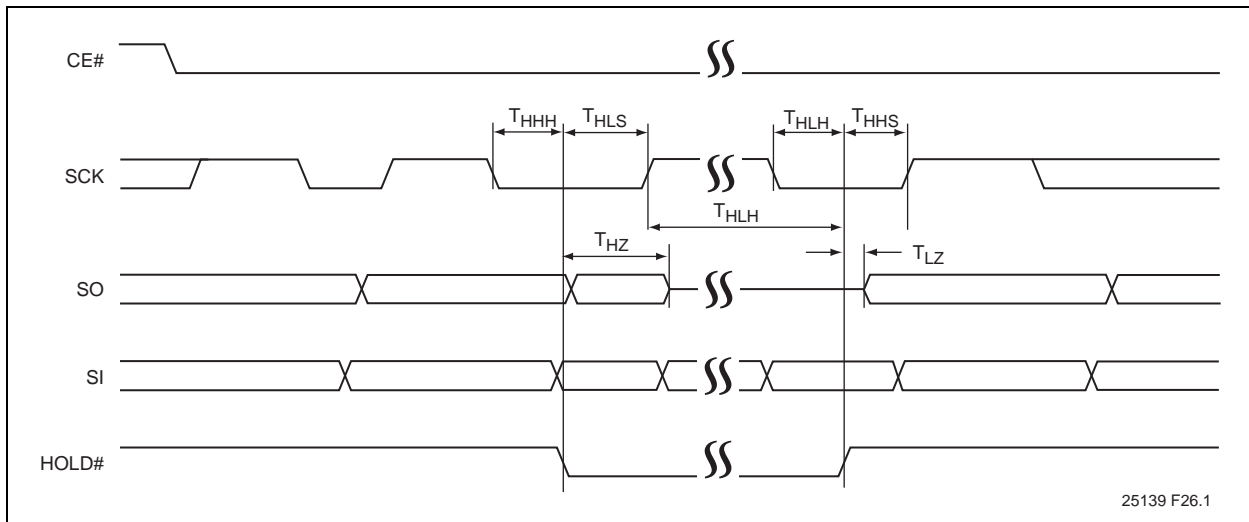

FIGURE 6-5: HOLD TIMING DIAGRAM

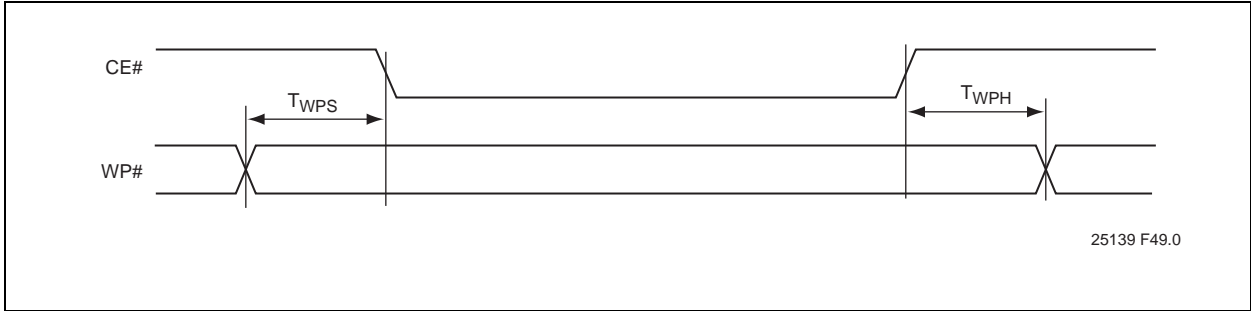

FIGURE 6-6: STATUS REGISTER WRITE TIMING

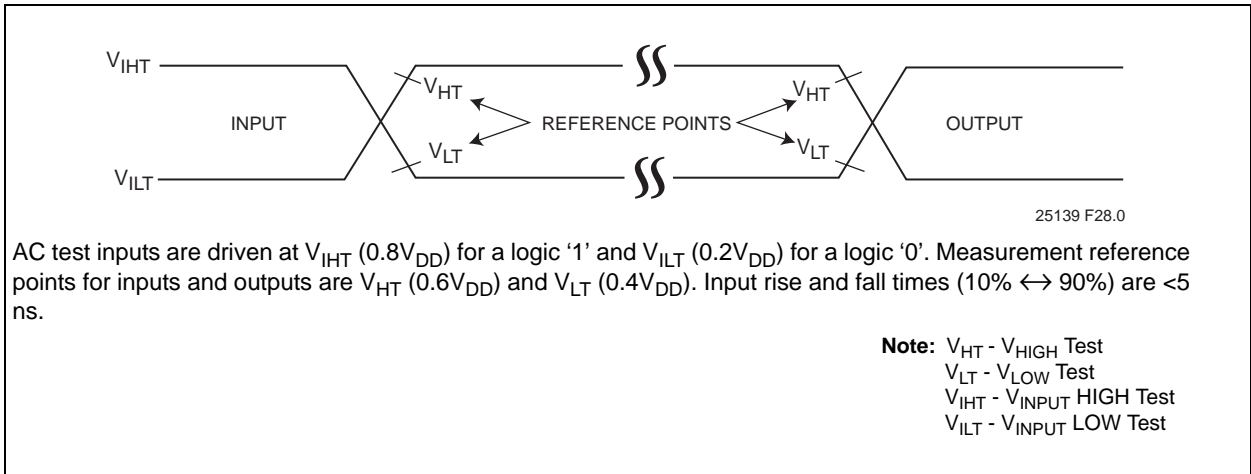
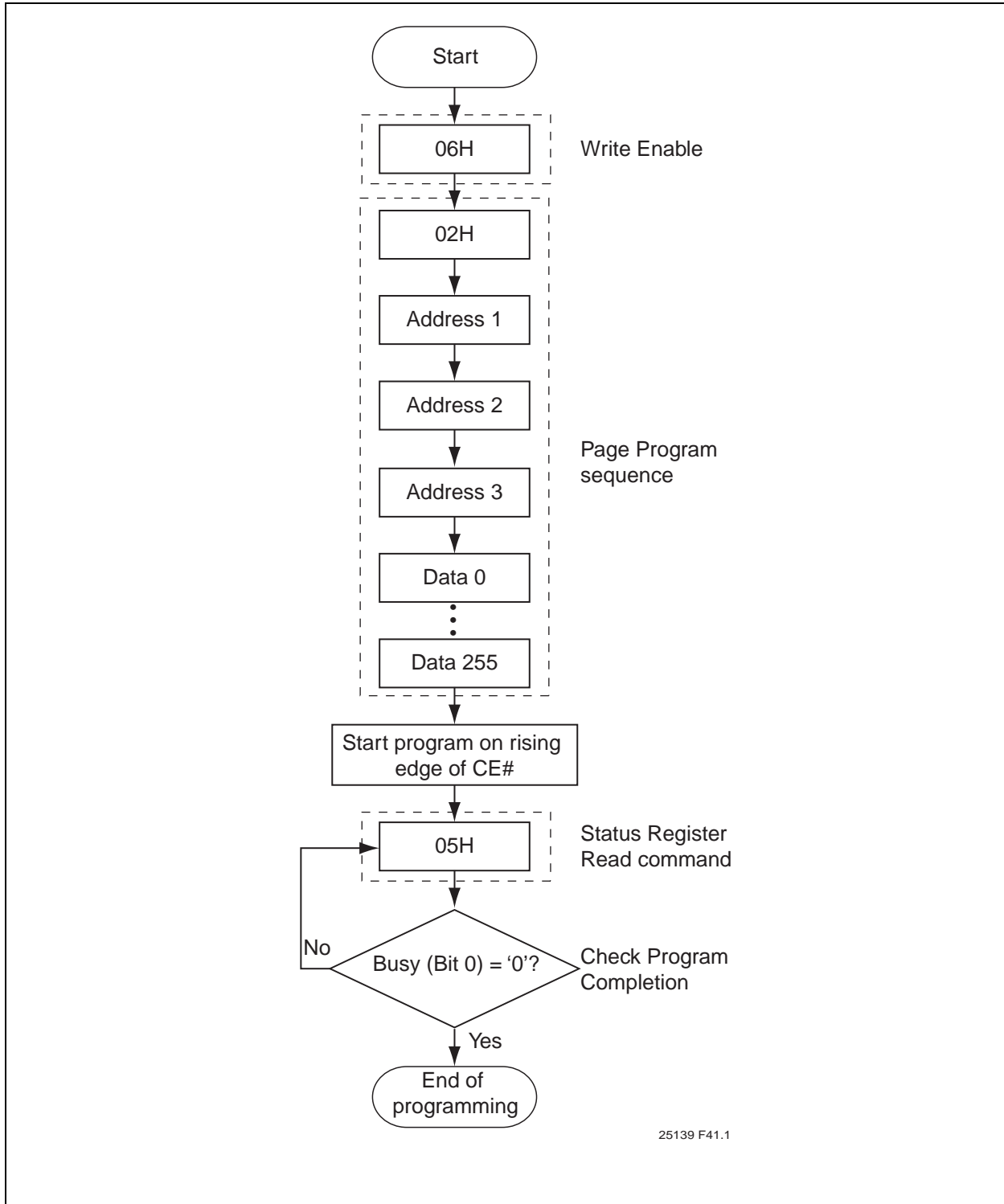

FIGURE 6-7: AC INPUT/OUTPUT REFERENCE WAVEFORMS



25139 F41.1

FIGURE 6-8: PAGE-PROGRAM FLOW CHART

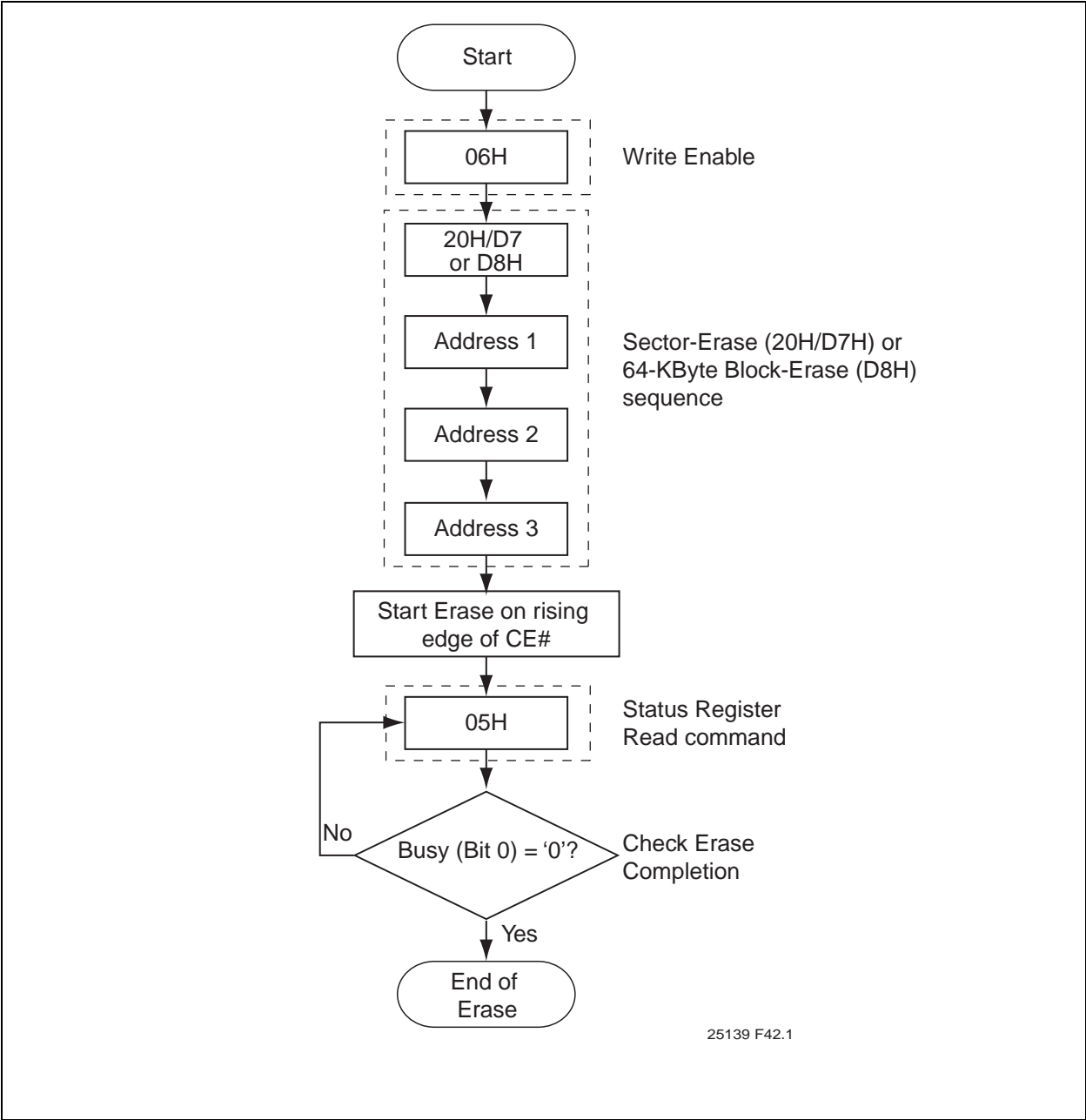

FIGURE 6-9: SECTOR-ERASE OR 64-KBYTE BLOCK-ERASE FLOW CHART

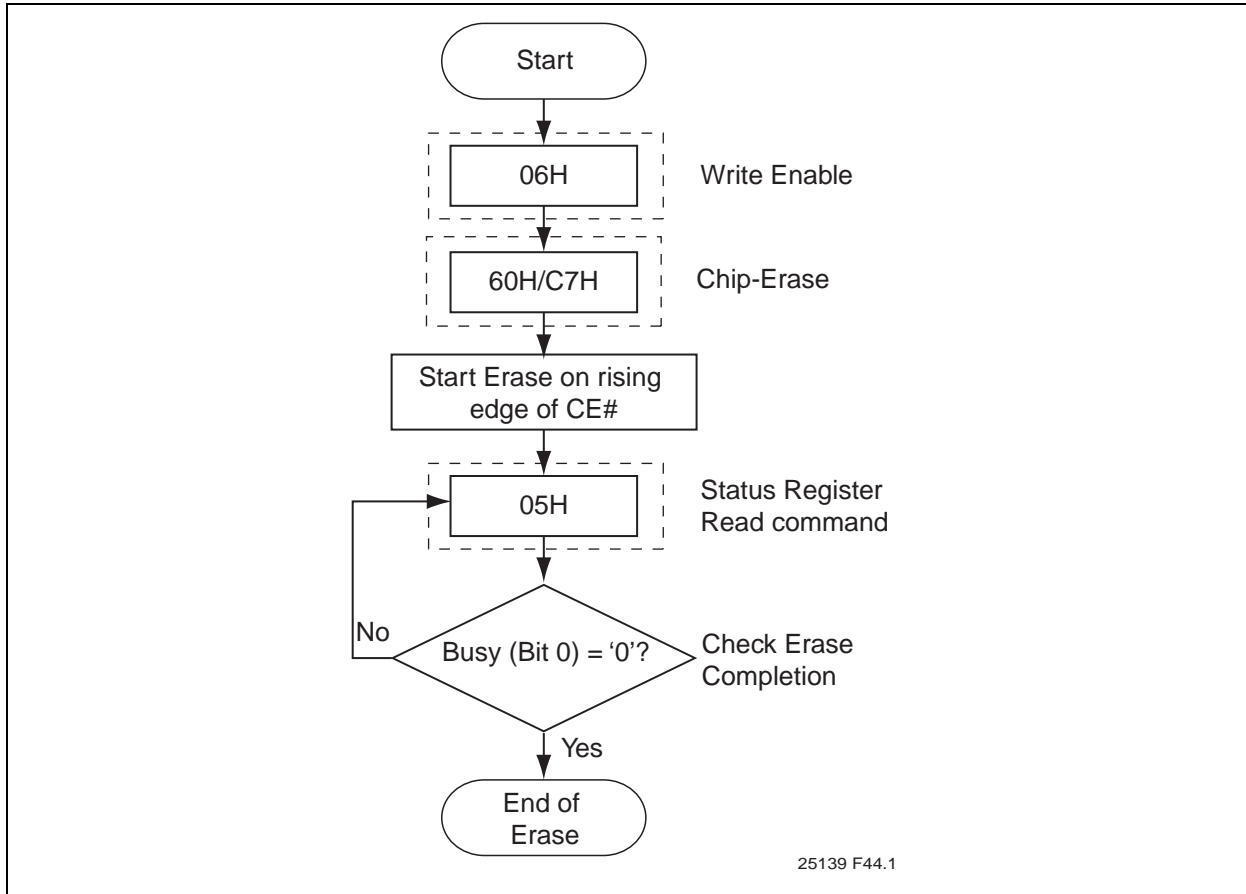
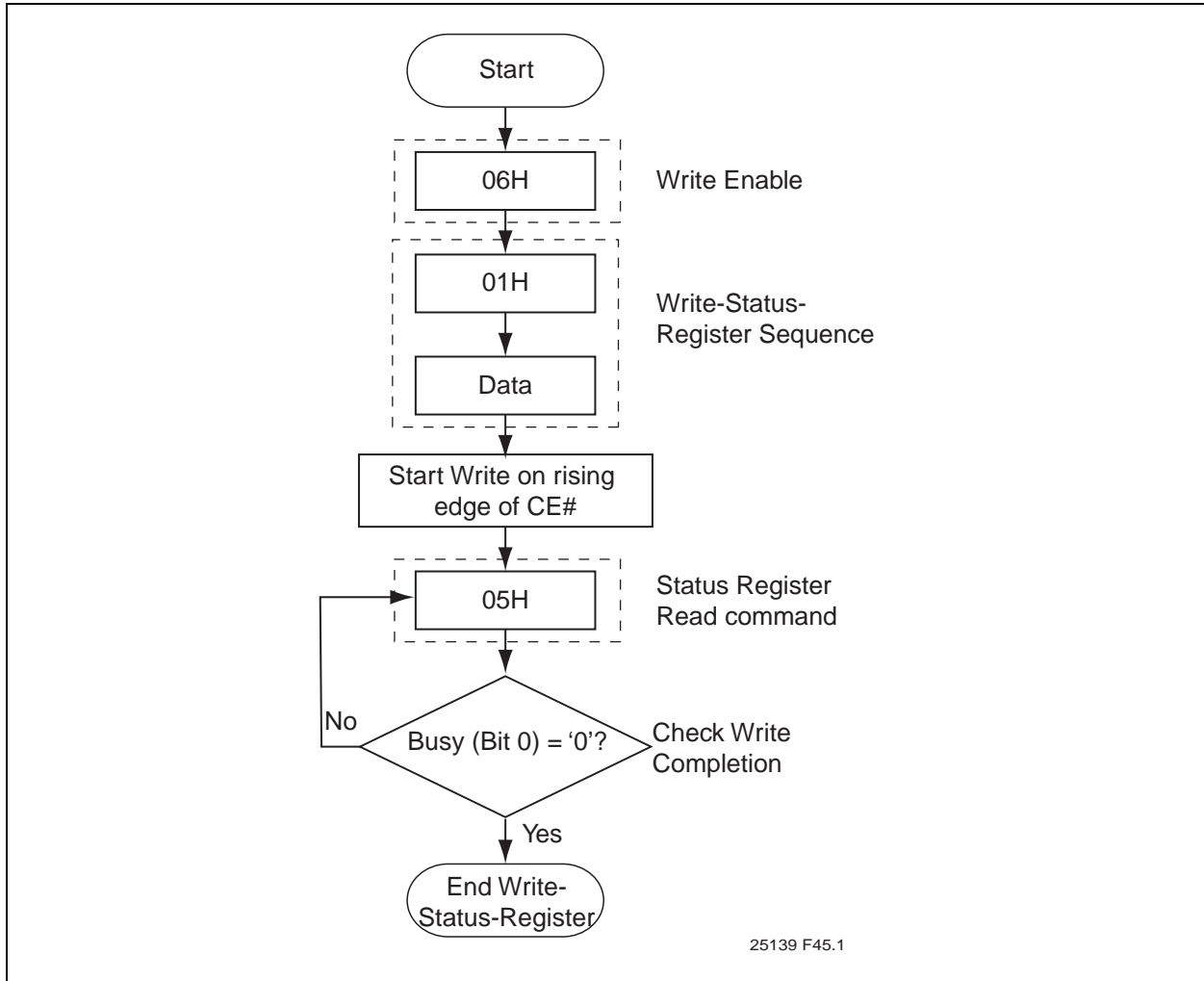

FIGURE 6-10: CHIP-ERASE FLOW CHART

**FIGURE 6-11: WRITE-STATUS-REGISTER (WRSR) FLOW CHART**

7.0 PRODUCT IDENTIFICATION SYSTEM

To order or obtain information, e.g., on pricing or delivery, refer to the factory or the listed sales office.

PART NO.	X	XXX	XX	XX
Device	Tape/Reel Indicator	Operating Frequency	Endurance/ Temperature	Package
Device:	SST25WF020A	= 2 Mbit, 1.65-1.95V, Serial Flash Memory		
Tape and Reel Flag:	T	= Tape and Reel		
Operating Frequency:	40	= 40 MHz		
Endurance:	5	= 100,000 cycles		
Temperature:	I	= -40°C to +85°C		
Package:	NP SN	= USON (2mm x 3mm Body), 8-contact = SOIC (150 mil Body), 8-lead		

Valid Combinations:
 SST25WF020AT-40-5I-NP
 SST25WF020A-40-5I-SN
 SST25WF020AT-40-5I-SN

8.0 PACKAGING DIAGRAMS

8-Lead Plastic Small Outline (SN) - Narrow, 3.90 mm Body [SOIC]

Note: For the most current package drawings, please see the Microchip Packaging Specification located at <http://www.microchip.com/packaging>

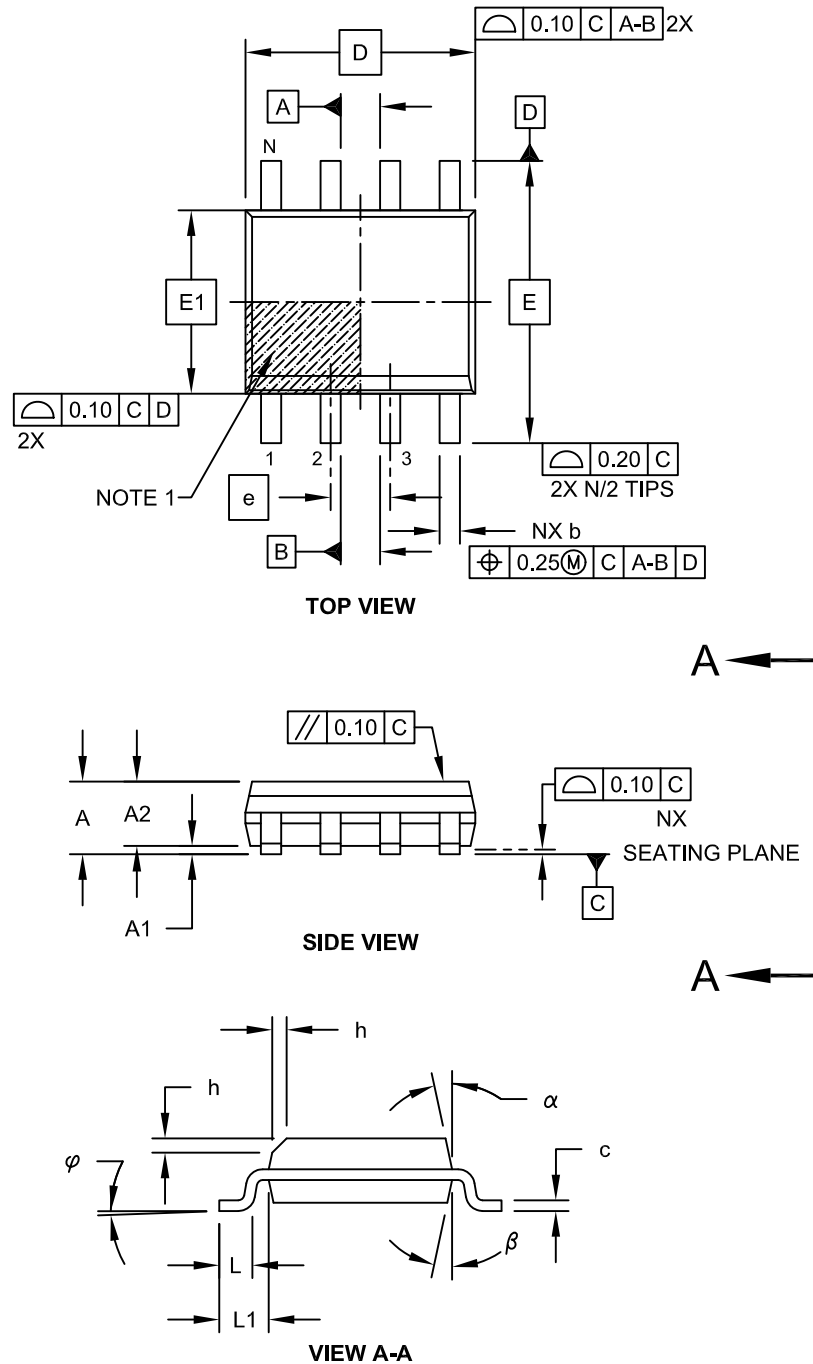

Microchip Technology Drawing No. C04-057C Sheet 1 of 2

8-Lead Plastic Small Outline (SN) - Narrow, 3.90 mm Body [SOIC]

Note: For the most current package drawings, please see the Microchip Packaging Specification located at <http://www.microchip.com/packaging>

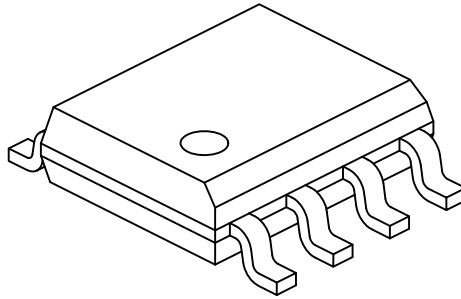

Dimension Limits	Units	MILLIMETERS		
		MIN	NOM	MAX
Number of Pins	N	8		
Pitch	e	1.27 BSC		
Overall Height	A	-	-	1.75
Molded Package Thickness	A2	1.25	-	-
Standoff §	A1	0.10	-	0.25
Overall Width	E	6.00 BSC		
Molded Package Width	E1	3.90 BSC		
Overall Length	D	4.90 BSC		
Chamfer (Optional)	h	0.25	-	0.50
Foot Length	L	0.40	-	1.27
Footprint	L1	1.04 REF		
Foot Angle	φ	0°	-	8°
Lead Thickness	c	0.17	-	0.25
Lead Width	b	0.31	-	0.51
Mold Draft Angle Top	α	5°	-	15°
Mold Draft Angle Bottom	β	5°	-	15°

Notes:

- Pin 1 visual index feature may vary, but must be located within the hatched area.
- § Significant Characteristic
- Dimensions D and E1 do not include mold flash or protrusions. Mold flash or protrusions shall not exceed 0.15mm per side.
- Dimensioning and tolerancing per ASME Y14.5M
 - BSC: Basic Dimension. Theoretically exact value shown without tolerances.
 - REF: Reference Dimension, usually without tolerance, for information purposes only.

Microchip Technology Drawing No. C04-057C Sheet 2 of 2

8-Lead Plastic Ultra Thin Small Outline No Lead Package (NP) - 2x3 mm Body [USON]

Note: For the most current package drawings, please see the Microchip Packaging Specification located at <http://www.microchip.com/packaging>

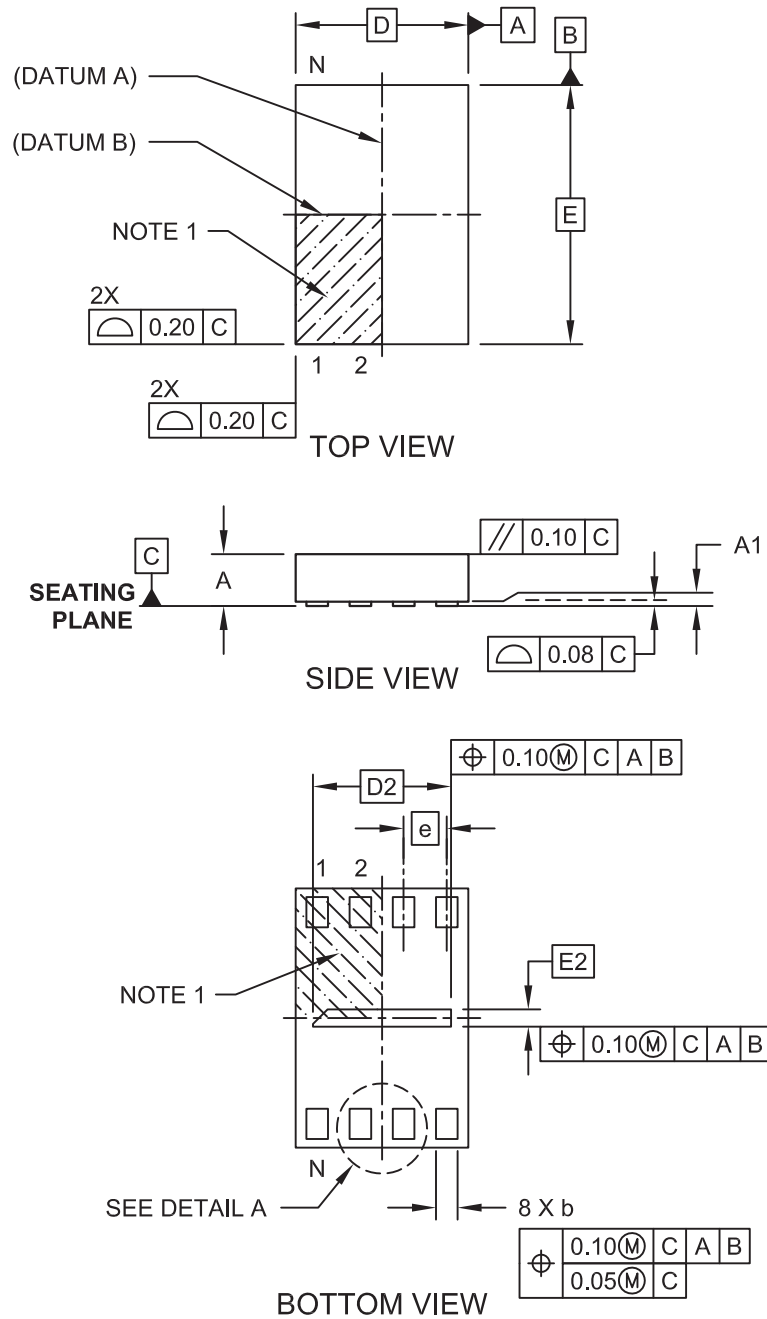

Microchip Technology Drawing C04-203A Sheet 1 of 2

8-Lead Plastic Ultra Thin Small Outline No Lead Package (NP) - 2x3 mm Body [USON]

Note: For the most current package drawings, please see the Microchip Packaging Specification located at <http://www.microchip.com/packaging>

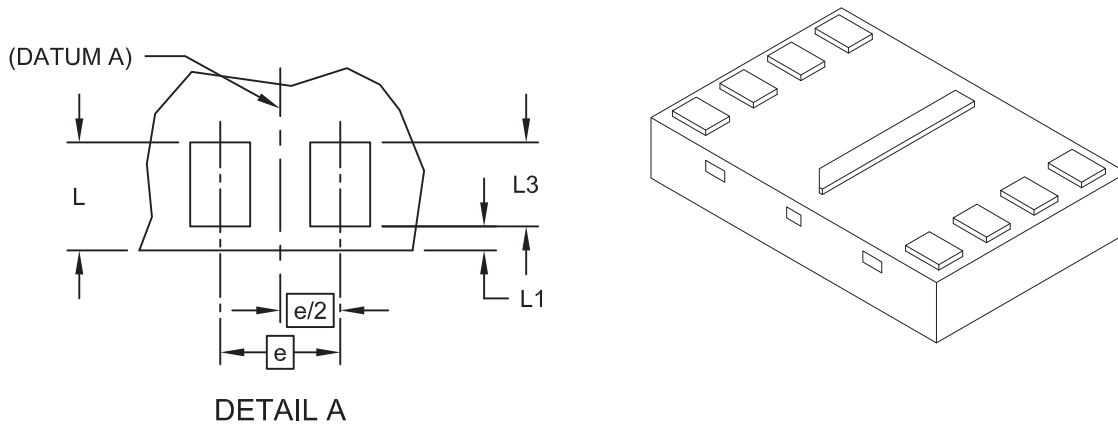

Units		MILLIMETERS		
Dimension Limits		MIN	NOM	MAX
Number of Terminals	N	8		
Pitch	e	0.50 BSC		
Overall Height	A	0.50	0.55	0.60
Standoff	A1	0.00	0.02	0.05
Overall Width	D	2.00 BSC		
Exposed Pad Width	D2	1.55	1.60	1.65
Overall Length	E	3.00 BSC		
Exposed Pad Length	E2	0.15	0.20	0.25
Terminal Width	b	0.20	0.25	0.30
Package Edge to Terminal Edge	L	0.40	0.45	0.50
Package Edge to Terminal Edge	L1	—	0.10	—
Terminal Length	L3	0.30	0.35	0.40

Notes:

1. Pin 1 visual index feature may vary, but must be located within the hatched area.
2. Package is saw singulated
3. Dimensioning and tolerancing per ASME Y14.5M

BSC: Basic Dimension. Theoretically exact value shown without tolerances.

REF: Reference Dimension, usually without tolerance, for information purposes only.

TABLE 8-1: REVISION HISTORY

Revision	Description	Date
A	• Initial release of data sheet	Feb 2013

THE MICROCHIP WEB SITE

Microchip provides online support via our WWW site at www.microchip.com. This web site is used as a means to make files and information easily available to customers. Accessible by using your favorite Internet browser, the web site contains the following information:

- **Product Support** – Data sheets and errata, application notes and sample programs, design resources, user's guides and hardware support documents, latest software releases and archived software
- **General Technical Support** – Frequently Asked Questions (FAQs), technical support requests, online discussion groups, Microchip consultant program member listing
- **Business of Microchip** – Product selector and ordering guides, latest Microchip press releases, listing of seminars and events, listings of Microchip sales offices, distributors and factory representatives

CUSTOMER CHANGE NOTIFICATION SERVICE

Microchip's customer notification service helps keep customers current on Microchip products. Subscribers will receive e-mail notification whenever there are changes, updates, revisions or errata related to a specified product family or development tool of interest.

To register, access the Microchip web site at www.microchip.com. Under "Support", click on "Customer Change Notification" and follow the registration instructions.

CUSTOMER SUPPORT

Users of Microchip products can receive assistance through several channels:

- Distributor or Representative
- Local Sales Office
- Field Application Engineer (FAE)
- Technical Support
- Development Systems Information Line

Customers should contact their distributor, representative or field application engineer (FAE) for support. Local sales offices are also available to help customers. A listing of sales offices and locations is included in the back of this document.

Technical support is available through the web site at: <http://microchip.com/support>

Note the following details of the code protection feature on Microchip devices:

- Microchip products meet the specification contained in their particular Microchip Data Sheet.
- Microchip believes that its family of products is one of the most secure families of its kind on the market today, when used in the intended manner and under normal conditions.
- There are dishonest and possibly illegal methods used to breach the code protection feature. All of these methods, to our knowledge, require using the Microchip products in a manner outside the operating specifications contained in Microchip's Data Sheets. Most likely, the person doing so is engaged in theft of intellectual property.
- Microchip is willing to work with the customer who is concerned about the integrity of their code.
- Neither Microchip nor any other semiconductor manufacturer can guarantee the security of their code. Code protection does not mean that we are guaranteeing the product as “unbreakable.”

Code protection is constantly evolving. We at Microchip are committed to continuously improving the code protection features of our products. Attempts to break Microchip's code protection feature may be a violation of the Digital Millennium Copyright Act. If such acts allow unauthorized access to your software or other copyrighted work, you may have a right to sue for relief under that Act.

Information contained in this publication regarding device applications and the like is provided only for your convenience and may be superseded by updates. It is your responsibility to ensure that your application meets with your specifications. MICROCHIP MAKES NO REPRESENTATIONS OR WARRANTIES OF ANY KIND WHETHER EXPRESS OR IMPLIED, WRITTEN OR ORAL, STATUTORY OR OTHERWISE, RELATED TO THE INFORMATION, INCLUDING BUT NOT LIMITED TO ITS CONDITION, QUALITY, PERFORMANCE, MERCHANTABILITY OR FITNESS FOR PURPOSE. Microchip disclaims all liability arising from this information and its use. Use of Microchip devices in life support and/or safety applications is entirely at the buyer's risk, and the buyer agrees to defend, indemnify and hold harmless Microchip from any and all damages, claims, suits, or expenses resulting from such use. No licenses are conveyed, implicitly or otherwise, under any Microchip intellectual property rights.

Trademarks

The Microchip name and logo, the Microchip logo, dsPIC, FlashFlex, KEELOQ, KEELOQ logo, MPLAB, PIC, PICmicro, PICSTART, PIC³² logo, rPIC, SST, SST Logo, SuperFlash and UNI/O are registered trademarks of Microchip Technology Incorporated in the U.S.A. and other countries.

FilterLab, Hampshire, HI-TECH C, Linear Active Thermistor, MTP, SEEVAL and The Embedded Control Solutions Company are registered trademarks of Microchip Technology Incorporated in the U.S.A.

Silicon Storage Technology is a registered trademark of Microchip Technology Inc. in other countries.

Analog-for-the-Digital Age, Application Maestro, BodyCom, chipKIT, chipKIT logo, CodeGuard, dsPICDEM, dsPICDEM.net, dsPICworks, dsSPEAK, ECAN, ECONOMONITOR, FanSense, HI-TIDE, In-Circuit Serial Programming, ICSP, Mindi, MiWi, MPASM, MPF, MPLAB Certified logo, MPLIB, MPLINK, mTouch, Omniclient Code Generation, PICC, PICC-18, PICDEM, PICDEM.net, PICkit, PICTail, REAL ICE, rLAB, Select Mode, SQI, Serial Quad I/O, Total Endurance, TSHARC, UniWinDriver, WiperLock, ZENA and Z-Scale are trademarks of Microchip Technology Incorporated in the U.S.A. and other countries.

SQTP is a service mark of Microchip Technology Incorporated in the U.S.A.

GestIC and ULPP are registered trademarks of Microchip Technology Germany II GmbH & Co. & KG, a subsidiary of Microchip Technology Inc., in other countries.

All other trademarks mentioned herein are property of their respective companies.

© 2013, Microchip Technology Incorporated, Printed in the U.S.A., All Rights Reserved.

 Printed on recycled paper.

ISBN: 978-1-62077-026-9

Microchip received ISO/TS-16949:2009 certification for its worldwide headquarters, design and wafer fabrication facilities in Chandler and Tempe, Arizona; Gresham, Oregon and design centers in California and India. The Company's quality system processes and procedures are for its PIC[®] MCUs and dsPIC[®] DSCs, KEELOQ[®] code hopping devices, Serial EEPROMs, microperipherals, nonvolatile memory and analog products. In addition, Microchip's quality system for the design and manufacture of development systems is ISO 9001:2000 certified.

**QUALITY MANAGEMENT SYSTEM
CERTIFIED BY DNV
= ISO/TS 16949 =**



Worldwide Sales and Service

AMERICAS

Corporate Office
2355 West Chandler Blvd.
Chandler, AZ 85224-6199
Tel: 480-792-7200
Fax: 480-792-7277
Technical Support:
[http://www.microchip.com/
support](http://www.microchip.com/support)
Web Address:
www.microchip.com

Atlanta

Duluth, GA
Tel: 678-957-9614
Fax: 678-957-1455

Boston

Westborough, MA
Tel: 774-760-0087
Fax: 774-760-0088

Chicago

Itasca, IL
Tel: 630-285-0071
Fax: 630-285-0075

Cleveland

Independence, OH
Tel: 216-447-0464
Fax: 216-447-0643

Dallas

Addison, TX
Tel: 972-818-7423
Fax: 972-818-2924

Detroit

Farmington Hills, MI
Tel: 248-538-2250
Fax: 248-538-2260

Indianapolis

Noblesville, IN
Tel: 317-773-8323
Fax: 317-773-5453

Los Angeles

Mission Viejo, CA
Tel: 949-462-9523
Fax: 949-462-9608

Santa Clara

Santa Clara, CA
Tel: 408-961-6444
Fax: 408-961-6445

Toronto

Mississauga, Ontario,
Canada
Tel: 905-673-0699
Fax: 905-673-6509

ASIA/PACIFIC

Asia Pacific Office
Suites 3707-14, 37th Floor
Tower 6, The Gateway
Harbour City, Kowloon
Hong Kong
Tel: 852-2401-1200
Fax: 852-2401-3431

Australia - Sydney

Tel: 61-2-9868-6733
Fax: 61-2-9868-6755

China - Beijing

Tel: 86-10-8569-7000
Fax: 86-10-8528-2104

China - Chengdu

Tel: 86-28-8665-5511
Fax: 86-28-8665-7889

China - Chongqing

Tel: 86-23-8980-9588
Fax: 86-23-8980-9500

China - Hangzhou

Tel: 86-571-2819-3187
Fax: 86-571-2819-3189

China - Hong Kong SAR

Tel: 852-2401-1200
Fax: 852-2401-3431

China - Nanjing

Tel: 86-25-8473-2460
Fax: 86-25-8473-2470

China - Qingdao

Tel: 86-532-8502-7355
Fax: 86-532-8502-7205

China - Shanghai

Tel: 86-21-5407-5533
Fax: 86-21-5407-5066

China - Shenyang

Tel: 86-24-2334-2829
Fax: 86-24-2334-2393

China - Shenzhen

Tel: 86-755-8203-2660
Fax: 86-755-8203-1760

China - Wuhan

Tel: 86-27-5980-5300
Fax: 86-27-5980-5118

China - Xian

Tel: 86-29-8833-7252
Fax: 86-29-8833-7256

China - Xiamen

Tel: 86-592-2388138
Fax: 86-592-2388130

China - Zhuhai

Tel: 86-756-3210040
Fax: 86-756-3210049

ASIA/PACIFIC

India - Bangalore
Tel: 91-80-3090-4444
Fax: 91-80-3090-4123

India - New Delhi

Tel: 91-11-4160-8631
Fax: 91-11-4160-8632

India - Pune

Tel: 91-20-2566-1512
Fax: 91-20-2566-1513

Japan - Osaka

Tel: 81-66-152-7160
Fax: 81-66-152-9310

Japan - Yokohama

Tel: 81-45-471- 6166
Fax: 81-45-471-6122

Korea - Daegu

Tel: 82-53-744-4301
Fax: 82-53-744-4302

Korea - Seoul

Tel: 82-2-554-7200
Fax: 82-2-558-5932 or
82-2-558-5934

Malaysia - Kuala Lumpur

Tel: 60-3-6201-9857
Fax: 60-3-6201-9859

Malaysia - Penang

Tel: 60-4-227-8870
Fax: 60-4-227-4068

Philippines - Manila

Tel: 63-2-634-9065
Fax: 63-2-634-9069

Singapore

Tel: 65-6334-8870
Fax: 65-6334-8850

Taiwan - Hsin Chu

Tel: 886-3-5778-366
Fax: 886-3-5770-955

Taiwan - Kaohsiung

Tel: 886-7-536-4818
Fax: 886-7-330-9305

Taiwan - Taipei

Tel: 886-2-2500-6610
Fax: 886-2-2508-0102

Thailand - Bangkok

Tel: 66-2-694-1351
Fax: 66-2-694-1350

EUROPE

Austria - Wels

Tel: 43-7242-2244-39
Fax: 43-7242-2244-393

Denmark - Copenhagen

Tel: 45-4450-2828
Fax: 45-4485-2829

France - Paris

Tel: 33-1-69-53-63-20
Fax: 33-1-69-30-90-79

Germany - Munich

Tel: 49-89-627-144-0
Fax: 49-89-627-144-44

Italy - Milan

Tel: 39-0331-742611
Fax: 39-0331-466781

Netherlands - Drunen

Tel: 31-416-690399
Fax: 31-416-690340

Spain - Madrid

Tel: 34-91-708-08-90
Fax: 34-91-708-08-91

UK - Wokingham

Tel: 44-118-921-5869
Fax: 44-118-921-5820