

■ GENERAL DESCRIPTION

The AMS6816 series are highly precise, low power consumption, 3 terminal, positive voltage regulators manufactured using CMOS and laser trimming technologies. The series provides large currents with a significantly small dropout voltage.

The AMS6816 consists of a current limiter circuit, a driver transistor, a precision reference voltage and an error correction circuit. The series is compatible with low ESR ceramic capacitors. The current limiter's foldback circuit operates as a short circuit protection as well as the output current limiter for the output pin.

Output voltages are internally by laser trimming technologies. It is selectable in 0.1V increments within a range of 1.5V to 5.0V.

SOT-23, SOT-89, TO-92 are available.

■ APPLICATIONS

- Battery powered equipment
- Reference voltage sources
- Cameras, video cameras
- Portable AV systems
- Mobile phones
- Portable games
- Cordless phones, wireless communication equipment

■ FEATURES

Maximum Output Current	: 500mA (Vin=3.8V, Vout=3.3V)
Dropout Voltage	: 0.5V@500mA
Maximum Operating Voltage	: 6.0V
Output Voltage Range	: 1.5V ~ 5.0V (0.1V increments)
Highly Accurate	: ±2%
Low Power Consumption	: 8 μA (TYP.)
Low ESR Capacitor	: Ceramic capacitor compatible
Protection	: Current Limit Circuit Built-in
Operating Ambient Temperature	: -25°C~ +85°C
Packages	: SOT-23 SOT-89 TO-92
Environmentally Friendly	: EU RoHS Compliant, Pb Free

■ TYPICAL APPLICATION CIRCUIT

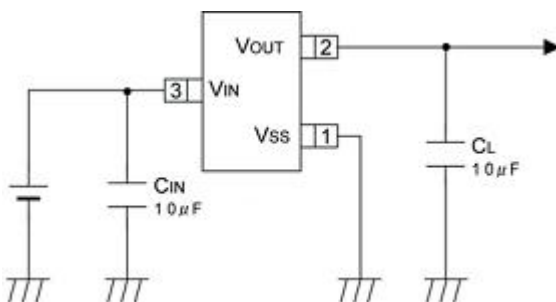

PIN CONFIGURATION

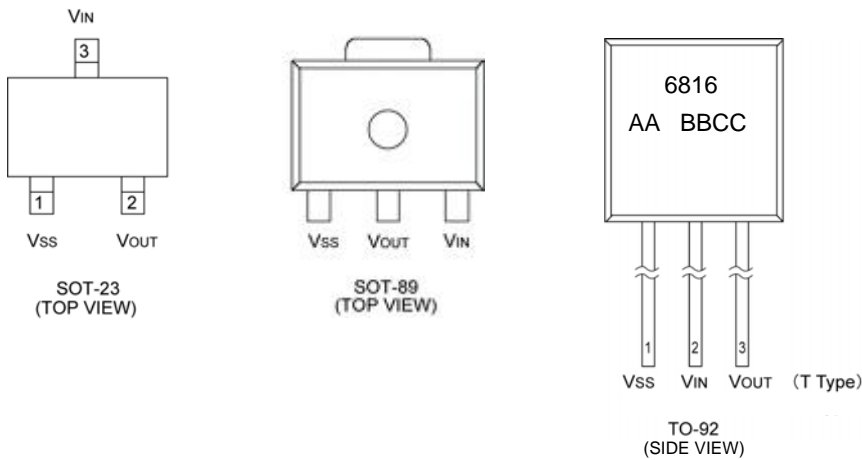

PIN ASSIGNMENT

PIN NUMBER			PIN NAME	FUNCTIONS
SOT-23	SOT-89	TO-92		
1	1	1	Vss	Ground
3	3	2	VIN	Power Input
2	2	3	VOUT	Output

PRODUCT CLASSIFICATION

Ordering Information

AMS6816 ①②③④⑤-⑥^(*)

DESIGNATOR	ITEM	SYMBOL	DESCRIPTION
①②	Output Voltage	12~50	e.g. V _{OUT} : 3.0V→①=3, ②=0
③	Accuracy	2	± 2% (V _{OUT} ≥ 1.5V), ±30mV (V _{OUT} < 1.5V)
		1	±1% (V _{OUT} ≥ 2.0V)
④⑤-⑥	Packages (Order Unit)	MR	SOT-23 (3,000/Reel)
		MR-G	SOT-23 (3,000/Reel)
		PR	SOT-89 (1,000/Reel)
		PR-G	SOT-89 (1,000/Reel)
		TH	TO-92 (T type), Paper type (2,000/Tape)
		TH-G	TO-92 (T type), Paper type (2,000/Tape)
		TB	TO-92 (T type), Bag type (500/Bag)
		TB-G	TO-92 (T type), Bag type (500/Bag)

^(*) The "-G" suffix denotes Halogen and Antimony free as well as being fully RoHS compliant.

■ BLOCK DIAGRAM

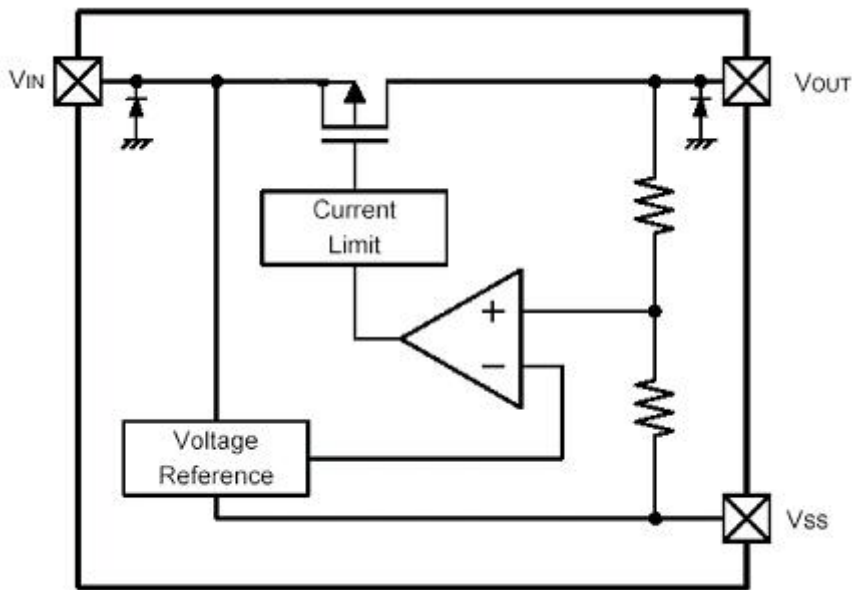

■ ABSOLUTE MAXIMUM RATINGS

Ta=25°C

PARAMETER	SYMBOL	RATINGS	UNITS
Input Voltage	V _{IN}	6.0	V
Output Current	I _{OUT}	500	mA
Output Voltage	V _{OUT}	V _{SS} - 0.3 ~ V _{IN} + 0.3	V
Power Dissipation	SOT-23	300	mW
	SOT-89	500	
	TO-92	500	
Operating Ambient Temperature	T _{opr}	- 25 ~ + 85	°C
Storage Temperature	T _{stg}	- 40 ~ + 125	°C

**●AMS6816**

Ta=25 °C

PARAMETER	SYMBOL	CONDITIONS ⁽¹⁾	MIN.	TYP.	MAX.	UNIT	S
Output Voltage	V _{out(E)} ⁽²⁾	I _{out} =10mA , V _{in} =V _{out} +1V	x 0.98	V _{OUT(T)} ⁽¹⁾	x 1.02	V	
Maximum Output Current	I _{outMAX}	V _{in} =V _{out} +1V		500	-	mA	
Load Regulation	ΔV _{out}	V _{in} =V _{out} +1V 1mA ≤ I _{out} ≤ 100mA		14		mV	
Dropout Voltage ⁽³⁾	V _{dif}	I _{out} =500mA		500		mV	
Supply Current	I _{ss}	V _{in} =V _{out} +1V		8		μA	
Line Regulation	$\frac{\Delta V_{OUT}}{\Delta V_{IN} \cdot V_{OUT}}$	V _{out} +1V ≤ V _{in} ≤ 6V I _{out} =40mA		0.03		%/V	
Input Voltage	V _{IN}			-	6.0	V	
Power Supply Ripple Rejection Ratio	PSRR	V _{in} =[V _{out} +1]V+1Vp-pAC I _{out} =10mA, f=1KHz		50		dB	

NOTE:* 1. V_{out(T)}: Specified Output Voltage* 2. V_{out(E)} :Effective output voltage (I.e. The output voltage when "V_{out(T)}+1.0V" is provided at the V_{in} pin while maintaining a certain I_{out} value.)* 3. V_{dif} : V_{IN1}-V_{out(E)}'V_{IN1} :The input voltage when V_{out(E)}' appears as input voltage is gradually decreased.V_{out(E)}' : A voltage equal to 98% of the output voltage whenever an amply stabilized {V_{OUT(T)} + 1.0V} is input .



■ PACKAGING INFORMATION

● SOT-23

Unit : mm

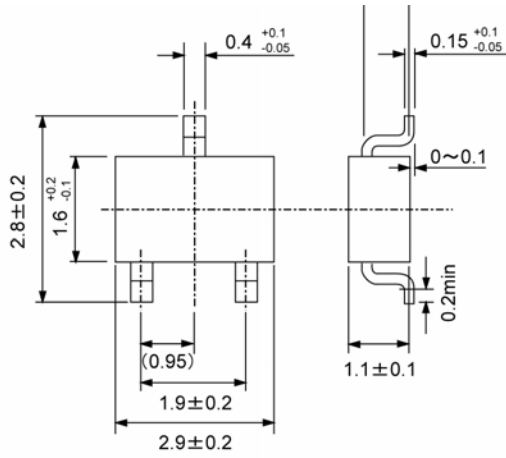

● SOT-89

Unit : mm

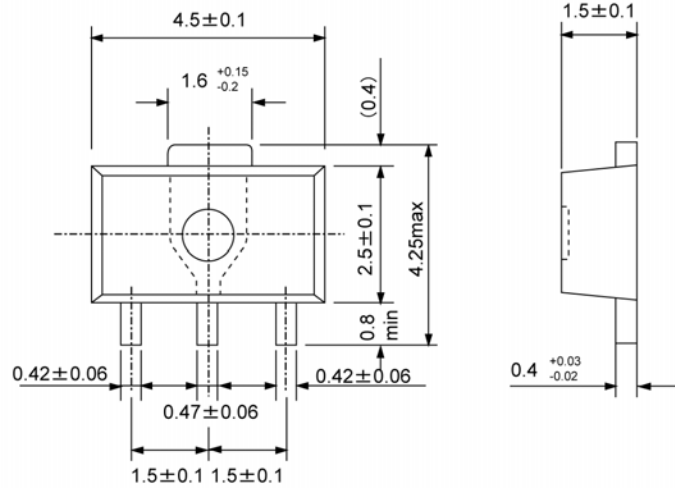

● TO-92

Unit : mm

