

# euro-block

product specification

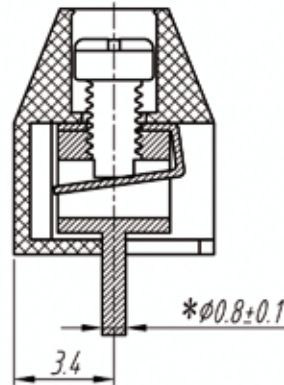

SECTION A-A

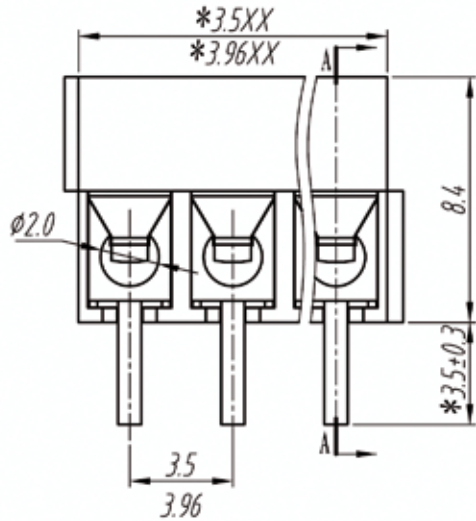
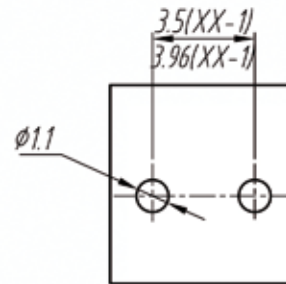

## Electrical

Standard: UL-IEC  
 Rated voltage: 300V-130V  
 Rated current: 10A-10A  
 Wire range: 24-18AWG-1mm<sup>2</sup>  
 Withstanding voltage: AC2000V/1Min

## Mechanical

Torque: 0.2Nm (1.7Lb'in)  
 Temp.Range: -40°C~+105°C  
 Strip length: 4.5-5mm

## Dimensions

Pitch: 3.50mm (0.138"), 3.96mm (0.156")  
 Poles: 2p-xxp

## Material

Housing: PA66, UL94V-0  
 Screws: M2, steel, Zinc plated  
 Pin header: Brass, Tin plated  
 Wire guard: Phosphor bronze, Ni plated

TOLERANCES EXCEPT AS NOTED

variable range	linear dimension				fillet	chamfer	short angle sid				≡	-	□	//	⊥	
	to 6	over 6 to 30	over 30 to 120	over 120 to 480	all	over 6 to 6	to 10	over 10 to 50	over 50 to 120	to 120	all	to 5	over 5 to 30	over 30 to 120	over 120 to 120	
tolerance	±0.1	±0.2	±0.3	±0.5	±0.2	±0.5	±1	1'	30'	20'	10'	0.5	0.025	0.06	0.12	0.4

UNITS	mm	SIZE	A4	SCALE	FIRST ANGLE PROJECTION	
<b>euro-block</b>						
					NAME	<b>BLT31-3.5-V</b>