

Customer Information Sheet

DRAWING No.: M90-706XX45

SHEET 2 OF 2

IF IN DOUBT - ASK

©

NOT TO SCALE

THIRD ANGLE PROJECTION

ALL DIMENSIONS IN mm

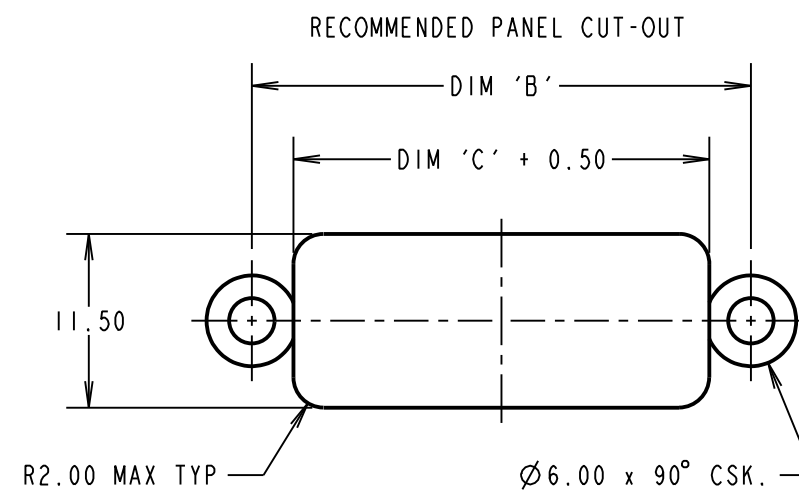
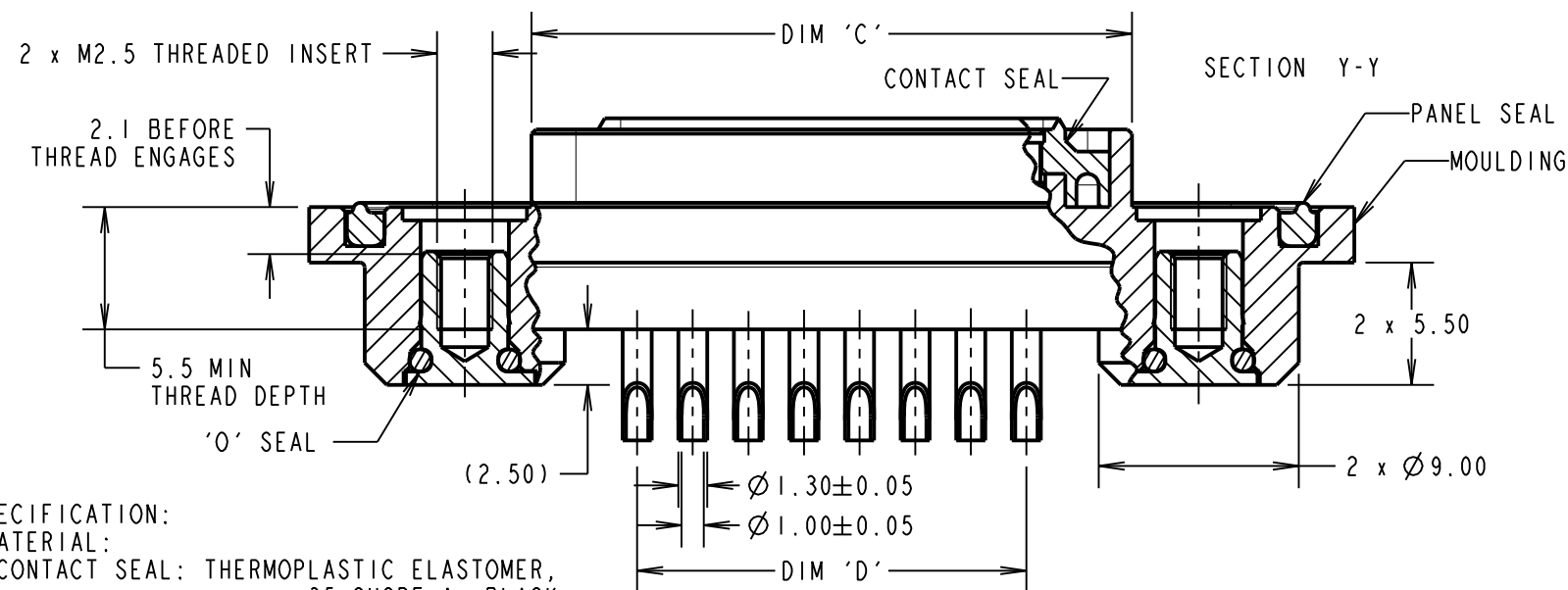
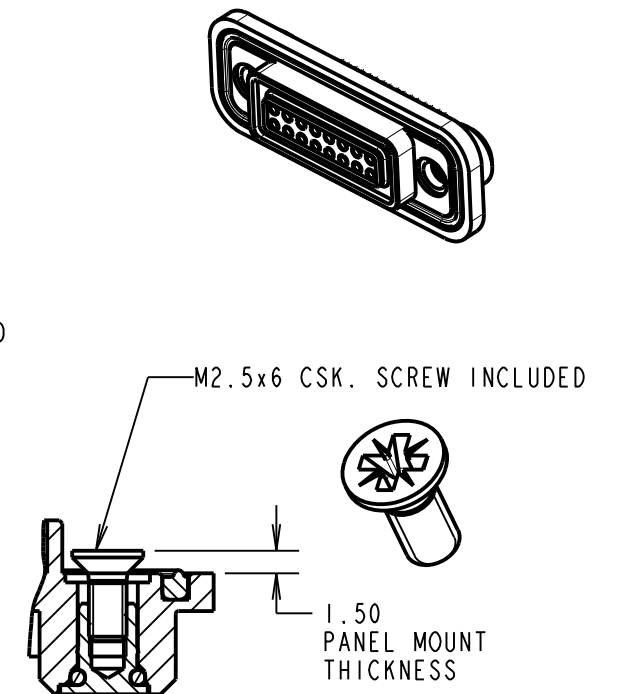
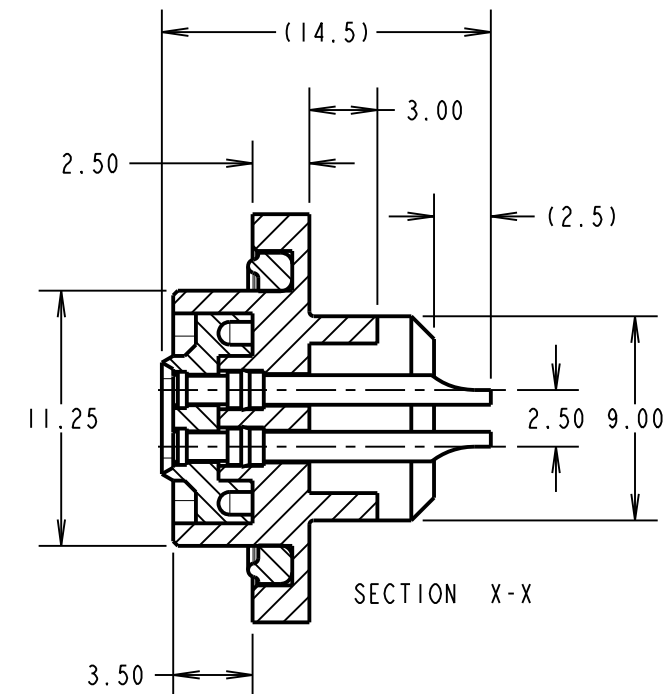
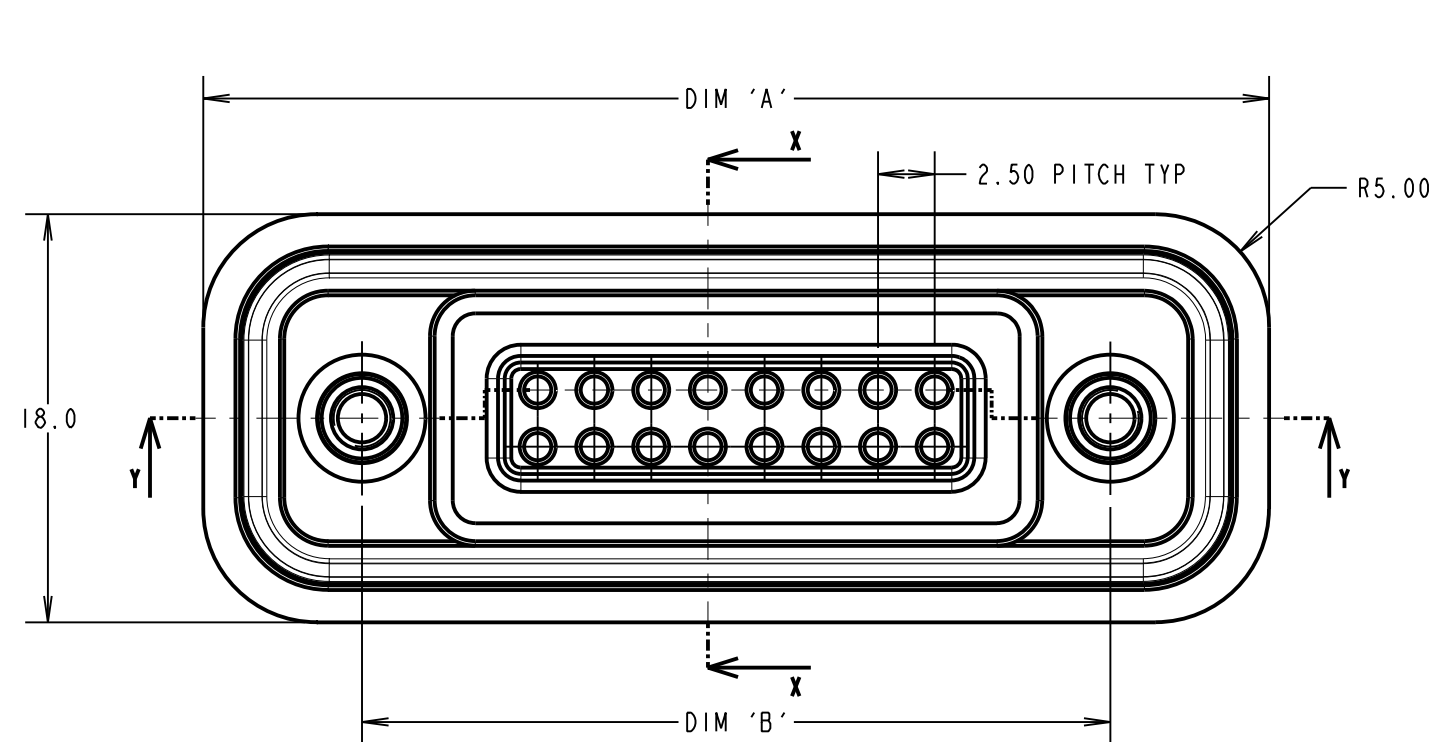

SPECIFICATION:

MATERIAL:
 CONTACT SEAL: THERMOPLASTIC ELASTOMER, 35 SHORE A, BLACK
 PANEL SEAL: NITRILE 30 SHORE A, BLACK
 O-SEAL: NITRILE 60/70 SHORE A, BLACK
 MOULDING: 30% GLASS FILLED POLYAMIDE 46, UL94V-0, BLACK
 CONTACT: BRASS
 THREADED INSERT AND SCREW: STAINLESS STEEL
 FINISH: CONTACT: GOLD OVER NICKEL
ELECTRICAL:
 CONTACT RATING: 1A
 WORKING VOLTAGE: 240V DC
 CONTACT RESISTANCE: 10 MILLIOHMS
 INSULATION RESISTANCE: 1000 MEGOHMS MIN AT 500V DC
ENVIRONMENTAL:
 OPERATING TEMPERATURE: -40°C - +100°C
 ENVIRONMENTAL SEAL: IP68 AT 1.5M FOR 2 HOURS

NOTES:

- DRAWING SHOWS 16-WAY CONNECTOR.
- RECOMMENDED BULKHEAD MOUNTING THICKNESS: 1.50mm.
- RECOMMENDED MOUNTING SCREWS: M2.5 x 6 CSK
- WHEN FULLY MATED WITH SPRING CONNECTOR, MOUNTING FLANGES WILL HAVE A GAP OF 3.5mm ± 0.10mm TO ALLOW FOR PANEL THICKNESS.
- SUITABLE FOR 22 AWG CABLE.

PART No.	No. OF WAYS	DIMENSION			
		A	B	C	D
M90-7060845	8 WAY	37.0	23.00	17.00	7.50
M90-7061245	12 WAY	42.0	28.00	22.00	12.50
M90-7061645	16 WAY	47.0	33.00	27.00	17.50

MGP	2	20.12.11	11602
NAME	ISS.	DATE	C/NOTE
APPROVED: MGP			
CHECKED: RA			
DRAWN: MARK G PLESTED			
CUSTOMER REF.:			
ASSEMBLY DRG:			

HARWIN

www.harwin.com
 technical@harwin.com

THIS DRAWING AND ANY INFORMATION OR DESCRIPTIVE MATTER SET OUT HEREON ARE CONFIDENTIAL AND COPYRIGHT PROPERTY OF THE HARWIN GROUP AND MUST NOT BE DISCLOSED, LOANED, COPIED OR USED FOR MANUFACTURING, TENDERING OR FOR ANY OTHER PURPOSE WITHOUT THEIR WRITTEN PERMISSION.

TOLERANCES
 X. = ±1mm
 X.X = ±0.25mm
 X.XX = ±0.10mm
 X.XXX = ±0.01mm
 ANGLES = ±5°
 UNLESS STATED

MATERIAL:
 SEE SPECIFICATION
FINISH:
S/AREA: mm²

TITLE:
 FIXED CONTACT ASSEMBLY
 22 AWG SOLDER TAILS

DRAWING NUMBER:
 M90-706XX45

SHT
 2 OF 2