



4x1Mx32 5V FLASH SIMM PRELIMINARY*

FEATURES

- Access Time of 90ns
- Packaging:
 - 80-pin SIMM
 - The module is manufactured with sixteen 1Mx8 CMOS Flash memory devices in TSOP on a laminate substrate.
- JEDEC standard
- Reset control options:
 - $\overline{\text{RESET}}$ tied to Vcc
 - $\overline{\text{RESET}}$ tied to pin 7 for system control of reset
 - $\overline{\text{RESET}}$ tied to Power Supervisor Circuit.
- Sector Architecture
 - 16 equal size sectors of 64KBytes per each 1Mx8 chip
 - Two step sequence of erase ensures that memory contents are not accidentally erased.
- AMD Part Number Am29F080-90 Flash Memory Components
- 100,000 Erase/Program Cycles
- Organized as four banks of 1Mx32
- Commercial Temperature Range
- 5 Volt Programming. $5V \pm 10\%$ Supply.
- Low Power CMOS (0 - 70°C)
- Built in Decoupling Caps and Multiple Ground Pins for Low Noise Operation, Separate Power and Ground Planes to improve noise immunity
- Standard Programming Algorithms for AMD Am29F080 Flash

* This data sheet describes a product under development, not fully characterized, and is subject to change without notice.

FIG. 1 PIN CONFIGURATION FOR WPF4M32XB-90PSC5X

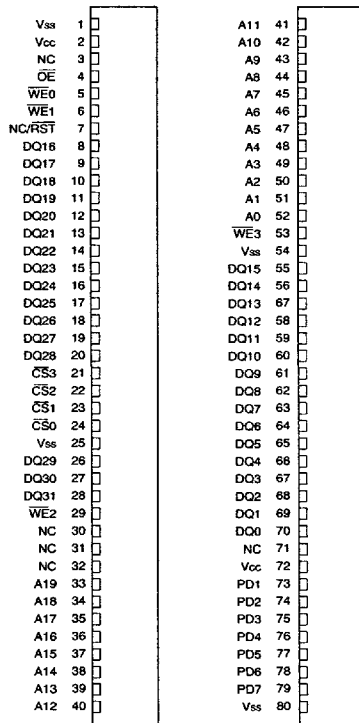

PIN DESCRIPTION

| | |
|---------------------------|---------------------|
| D/Q0-31 | Data Inputs/Outputs |
| A0-19 | Address Inputs |
| $\overline{\text{WE}}0-3$ | Write Enables |
| $\overline{\text{CS}}0-3$ | Chip Enables |
| $\overline{\text{OE}}$ | Output Enable |
| RST | Reset (Optional) |
| Vcc | Power Supply |
| Vss | Ground |
| PD1-7 | Presence Detect |
| NC | No Connect |

Presence Detect

| Speed | PD1 | PD2 | PD3 | PD4 | PD5 | PD6 | PD7 |
|-------|--------|-----|---------|-----|-----|-----|-----|
| 90ns | 1 | 1 | 0 | 0 | 1 | 1 | 0 |
| | 0: GND | | 1: Open | | | | |

BLOCK DIAGRAM

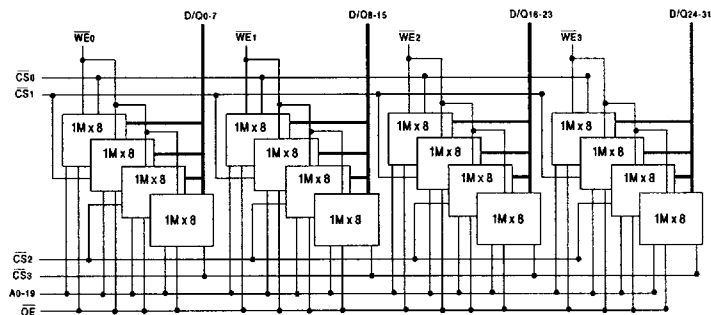

FLASH SIMMS

1563698 0001861 125

**ABSOLUTE MAXIMUM RATINGS**

| Parameter | Symbol | Ratings | Unit |
|---|------------------|--------------|------|
| Voltage on Any Pin Relative to Vss (except Vcc and Vpp) | V _T | -2.0 to +7.0 | V |
| Power Dissipation | P _T | 1.43 | W |
| Operating Temperature | T _A | 0 to +70 | °C |
| Storage Temperature | T _{stg} | -65 to +125 | °C |
| Short Circuit Output Current | I _{os} | 200 | mA |

CAPACITANCE(T_A = +25°C)

| Parameter | Symbol | Conditions | Max | Uni |
|---------------------------|-----------------|------------------------------------|-----|-----|
| OE capacitance | C _{OE} | V _{IN} = 0 V, f = 1.0 MHz | 156 | pF |
| WE0-3 capacitance | C _{WE} | V _{IN} = 0 V, f = 1.0 MHz | 44 | pF |
| CE1-2 capacitance | C _{CS} | V _{IN} = 0 V, f = 1.0 MHz | 50 | pF |
| Data D/Q capacitance | C _{IO} | V _{IO} = 0 V, f = 1.0 MHz | 42 | pF |
| Address input capacitance | C _{AD} | V _{IN} = 0 V, f = 1.0 MHz | 156 | pF |

This parameter is guaranteed by design but not tested.

RECOMMENDED DC OPERATING CONDITIONS

| Parameter | Symbol | Min | Typ | Max | Unit |
|---|-----------------|-----------------------|-----|-----------------------|------|
| Supply Voltage | V _{CC} | 4.5 | 5.0 | 5.5 | V |
| Ground | V _{SS} | 0 | 0 | 0 | V |
| Input High Voltage | V _{IH} | 0.7 x V _{CC} | - | V _{CC} + 0.5 | V |
| Input Low Voltage | V _{IL} | -0.5 | - | +0.8 | V |
| Voltage for Autoselect and Sector Unprotect | V _{ID} | 11.5 | - | 12.5 | V |

DC CHARACTERISTICS - CMOS COMPATIBLE(V_{CC} = 5.0V, V_{SS} = 0V, T_A = 0°C to +70°C)**FLASH SIMMS**

| Parameter | Symbol | Conditions | Min | Max | Unit |
|---|--------------------|---|------------------------|------|------|
| Input Leakage Current | I _{LI} | V _{CC} = 5.5, V _{IN} = GND or V _{CC} | | 10 | μA |
| Output Leakage Current | I _{LOx32} | V _{CC} = 5.5, V _{IN} = GND or V _{CC} | | 10 | μA |
| Vcc Active Current for Read (1) | I _{CC1} | $\overline{CS} = V_{IL}, \overline{OE} = V_{IH}, f = 5\text{MHz}$ | | 123 | mA |
| Vcc Active Current for Program or Erase (2) | I _{CC2} | $\overline{CS} = V_{IL}, \overline{OE} = V_{IH}$ | | 243 | mA |
| Vcc Standby Current | I _{CC4} | V _{CC} = 5.5, $\overline{CS} = V_{IH}, f = 5\text{MHz}$ | | 4.0 | mA |
| Vcc Static Current | I _{CC3} | V _{CC} = 5.5, $\overline{CS} = V_{IH}$ | | 160 | μA |
| Output Low Voltage | V _{OL} | I _{OL} = 12.0 mA, V _{CC} = 4.5 | | 0.45 | V |
| Output High Voltage | V _{OH1} | I _{OH} = 2.5 mA, V _{CC} = 4.5 | 0.85 x V _{CC} | | V |
| Low Vcc Lock-Out Voltage | V _{LKO} | | 3.2 | 4.2 | V |

NOTES:

- The I_{CC} current listed includes both the DC operating current and the frequency dependent component (@ 5MHz). The frequency component typically is less than 2mA/MHz, with OE at V_{IH}.
- I_{CC} active while Embedded Algorithm (program or erase) is in progress.
- DC test conditions V_{IL} = 0.3V, V_{IH} = V_{CC} - 0.3V



AC CHARACTERISTICS – WRITE/ERASE/PROGRAM OPERATIONS, WE CONTROLLED

(Vcc = 5.0V, TA = 0°C to +70°C)

| Parameter | Symbol | | -90 | | Unit |
|--|---------|-------|-----|-----|------|
| | | | Min | Max | |
| Write Cycle Time | t AVAV | tWC | 90 | | ns |
| Chip Select Setup Time | t ELWL | tCS | 0 | | ns |
| Write Enable Pulse Width | t WLWH | tWP | 45 | | ns |
| Address Setup Time | t AVWH | tAS | 0 | | ns |
| Data Setup Time | t DVWH | tDS | 45 | | ns |
| Data Hold Time | t WHDX | tDH | 0 | | ns |
| Address Hold Time | t WHAX | tAH | 45 | | ns |
| Write Enable Pulse Width High | t WHWL | tWPH | 20 | | ns |
| Duration of Byte Programming Operation | t WHWH1 | | | 1.0 | ms |
| Sector Erase Time | t WHWH2 | | | 15 | sec |
| Read Recovery Time before Write | t GHWL | | 0 | | µs |
| Vcc Set-up Time | tVCS | | 50 | | µs |
| Chip Programming Time | | | | 50 | sec |
| Output Enable Setup Time | | t OES | 0 | | ns |
| Output Enable Hold Time (1) | | t OEH | 10 | | ns |
| Chip Erase Time | | | | 240 | sec |
| RESET Pulse Width (2) | | t RP | 500 | | ns |

- 1. For Toggle and Data Polling.
- 2. Reset optional.

AC CHARACTERISTICS – READ ONLY OPERATIONS

(Vcc = 5.0V, TA = 0°C to +70°C)

| Parameter | Symbol | | -90 | | Unit |
|---|--------|---------|-----|-----|------|
| | | | Min | Max | |
| Read Cycle Time | t AVAV | tRC | 90 | | ns |
| Address Access Time | t AVQV | tACC | | 90 | ns |
| Chip Select Access Time | t ELOV | tCE | | 90 | ns |
| Output Enable to Output Valid | t GLOV | tOE | | 40 | ns |
| Chip Select to Output High Z (1) | t EHQZ | tDF | | 20 | ns |
| Output Enable High to Output High Z (1) | t GHQZ | tDF | | 20 | ns |
| Output Hold from Address, CS or OE Change, whichever is First | t HXOX | tOH | 0 | | ns |
| RST Low to Read Mode (1) (2) | | t Ready | | 20 | µs |

- 1. Guaranteed by design, but not tested.
- 2. Reset optional.

FLASH SIMMS



AC CHARACTERISTICS – WRITE/ERASE/PROGRAM OPERATIONS, \overline{CS} CONTROLLED
(V_{CC} = 5.0V, V_{SS} = 0V, T_A = 0°C to +70°C)

| Parameter | Symbol | | -90 | | Unit |
|--|--------------------|------------------|-----|-----|------|
| | | | Min | Max | |
| Write Cycle Time | t _{AVAV} | t _{wc} | 90 | | ns |
| Write Enable Setup Time | t _{WLEL} | t _{ws} | 0 | | ns |
| Chip Select Pulse Width | t _{ELEH} | t _{CP} | 45 | | ns |
| Address Setup Time | t _{AVEL} | t _{AS} | 0 | | ns |
| Data Setup Time | t _{DVEH} | t _{DS} | 45 | | ns |
| Data Hold Time | t _{EHDX} | t _{DH} | 0 | | ns |
| Address Hold Time | t _{ELAX} | t _{AH} | 45 | | ns |
| Chip Select Pulse Width High | t _{EHEL} | t _{CPH} | 20 | | ns |
| Duration of Byte Programming Operation | t _{WHWH1} | | | 1.0 | ms |
| Sector Erase Time | t _{WHWH2} | | | 15 | sec |
| Read Recovery Time | t _{GHEL} | | 0 | | μs |
| Chip Programming Time | | | | 50 | sec |
| Chip Erase Time | | | | 240 | sec |

FLASH SIMMS

■ 1563698 0001864 934 ■



PACKAGE : 80-PIN SIMM

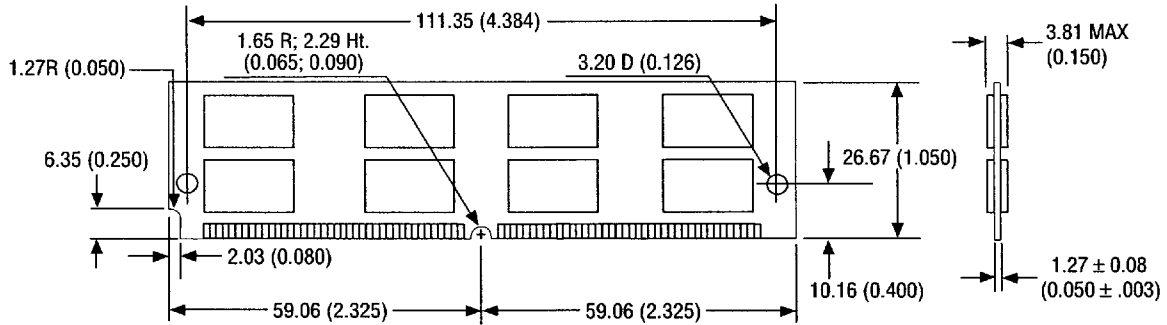

±0.13 (±0.005) TOLERANCE UNLESS OTHERWISE SPECIFIED
 ALL LINEAR DIMENSIONS ARE MILLIMETERS AND PARENTHECALLY IN INCHES

ORDERING INFORMATION

W P F 4M32 X B - 90 P S C 5 X

LEAD FINISH:

- T = Tin Edge Connectors
- Blank = Gold Edge Connectors

V_{PP} PROGRAMMING VOLTAGE

5 = 5V

DEVICE GRADE:

C = Commercial 0 to + 70 °C

PACKAGE TYPE:

PS = 80 pin Plastic SIMM

ACCESS TIME in ns

A = Four banks of 1M x 32

RESET OPTIONS:

- V = RESET tied to V_{cc}
- R = RESET tied to Pin 7 for system control of reset
- B = RESET tied to power supervisor circuit
On-board active Reset control

ORGANIZATION, four banks of 1M x 32

Flash PROM

Plastic Module

WHITE MICROELECTRONICS

FLASH SIMMS