

DM74AS240, 244 TRI-STATE® Bus Driver/Receiver

General Description

This family of Advance Schottky TRI-STATE Bus circuits are designed to provide either bidirectional or unidirectional buffer interface in Memory, Microprocessor, and Communication Systems. The output characteristics of the circuits have low impedance sufficient to drive terminated transmission lines down to 133 ohms. The input characteristics of the circuits likewise have a high impedance so it will not significantly load the transmission line. The package contains eight TRI-STATE buffers organized with four buffers having a common TRI-STATE enable gate. The AS240 and 244 are eight wide in a 20 pin package, and may be used as a 4 wide bidirectional or eight wide unidirectional. The buffer selection includes inverting and non-inverting, with enable or disable TRI-STATE control.

Features

- Advanced oxide-isolated, ion-implanted Schottky TTL process
- Improved switching performance with less power dissipation compared with Schottky counterpart
- Functional and pin compatible with 54/74LS and Schottky counterpart
- Switching response specified into 500 ohm and 50 pF
- Specified to interface with CMOS at $V_{OH} = V_{CC} - 2V$

Connection Diagrams

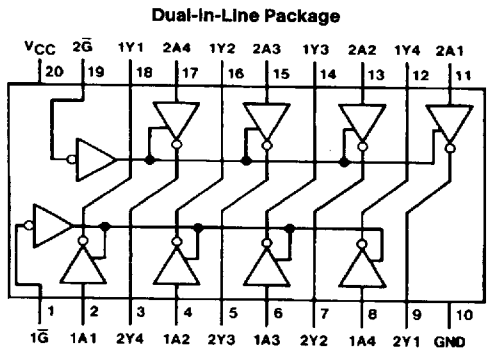

Order Number DM74AS240WM or DM74AS240N
See NS Package Number M20B or N20A

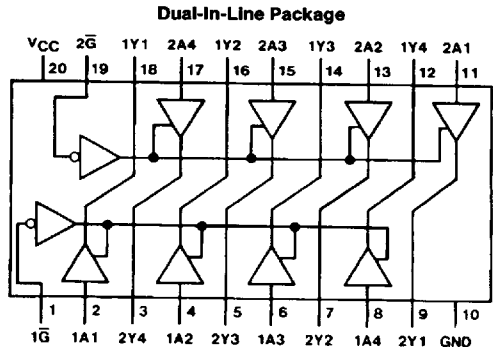

Order Number DM74AS244WM or DM74AS244N
See NS Package Number M20B or N20A

Function Tables

AS240

Inputs		Output
\bar{G}	A	Y
L	L	H
L	H	L
H	X	Z

AS244

Inputs		Output
\bar{G}	A	Y
L	L	L
L	H	H
H	X	Z

L = Low Logic Level H = High Logic Level X = Either Low or High Logic Level Z = High Impedance

TRI-STATE® is a registered trademark of National Semiconductor Corporation.

Absolute Maximum Ratings

Supply Voltage, V_{CC}	7V
Input Voltage	7V
Voltage Applied to Disabled Output	5.5V
Operating Free Air Temperature Range	0°C to +70°C
Storage Temperature Range	-65°C to +150°C
Typical θ_{JA}	
AS240/244 N Package	57.0°C/W
M Package	76.0°C/W

Note: The "Absolute Maximum Ratings" are those values beyond which the safety of the device cannot be guaranteed. The device should not be operated at these limits. The parametric values defined in the "Electrical Characteristics" table are not guaranteed at the absolute maximum ratings. The "Recommended Operating Conditions" table will define the conditions for actual device operation.

Note: This product meets application requirements of 500 temperature cycles from -65°C to +150°C.

Recommended Operating Conditions

Symbol	Parameter	Min	Nom	Max	Units
V_{CC}	Supply Voltage	4.5	5	5.5	V
V_{IH}	High Level Input Voltage	2			V
V_{IL}	Low Level Input Voltage			0.8	V
I_{OH}	High Level Output Current			-15	mA
I_{OL}	Low Level Output Current			64	mA
T_A	Free Air Operating Temperature	0		70	°C

Electrical Characteristics

over recommended operating free air temperature range. All typical values are measured at $V_{CC} = 5V$, $T_A = 25^\circ C$.

Symbol	Parameter	Conditions		Min	Typ	Max	Units
V_{IK}	Input Clamp Voltage	$V_{CC} = 4.5V$, $I_{IN} = -18 mA$				-1.2	V
V_{OH}	High Level Output Voltage	$V_{CC} = 4.5V$, $I_{OH} = -3 mA$		2.4	3.2		V
		$V_{CC} = 4.5V$, $I_{OH} = Max$		2.4			
		$I_{OH} = -2 mA$, $V_{CC} = 4.5V$ to $5.5V$		$V_{CC} - 2$			
V_{OL}	Low Level Output Voltage	$V_{CC} = 4.5V$, $I_{OL} = Max$			0.35	0.55	V
I_I	Input Current at Max Input Voltage	$V_{CC} = 5.5V$	$V_{IN} = 7V$	Others		100	μA
I_{IH}	High Level Input Current	$V_{CC} = 5.5V$, $V_{IN} = 2.7V$		Others		20	μA
I_{IL}	Low Level Input Current	$V_{CC} = 5.5V$, $V_{IN} = 0.4V$		AS240, (G, \bar{G}), (Control Inputs), 244 (\bar{G})		-500	μA
				244 (A)		-1000	
I_{OZH}	High Level TRI-STATE Output Current	$V_{CC} = 5.5V$, $V = 2.7V$				50	μA

Electrical Characteristics

over recommended operating free air temperature range. All typical values are measured at $V_{CC} = 5V$, $T_A = 25^\circ C$. (Continued)

Symbol	Parameter	Conditions	Min	Typ	Max	Units	
I_{OZL}	Low Level TRI-STATE Output Current	$V_{CC} = 5.5V$, $V = 0.4V$	AS240, AS244		-50	μA	
I_O (Note)	Output Drive Current	$V_{CC} = 5.5V$, $V_{OUT} = 2.25V$	-50	-115	-150	mA	
I_{CC}	AS240 Supply Current	$V_{CC} = 5.5V$	Outputs High		11	17	mA
			Outputs Low		51	75	
			TRI-STATE		24	38	
I_{CC}	AS244 Supply Current	$V_{CC} = 5.5V$	Outputs High		22	34	mA
			Outputs Low		60	90	
			TRI-STATE		34	54	

Note: The output conditions have been chosen to produce a current that closely approximates one half the true short-circuit output current, I_{OS} .

'AS240 Switching Characteristics

over recommended operating free air temperature range (Note 1)

Symbol	Parameter	Conditions	From (Input)	To (Output)	Min	Max	Units
t_{PLH}	Propagation Delay Time Low-to-High Level Output	$V_{CC} = 4.5V$ to $5.5V$ $R_1 = R_2 = 500\Omega$ $C_L = 50 pF$	A	Y	2	6.5	ns
t_{PHL}	Propagation Delay Time High-to-Low Level Output		A	Y	2	5.7	ns
t_{PZL}	Output Enable to Low Level		\bar{G}	Y	2	9	ns
t_{PZH}	Output Enable to High Level		\bar{G}	Y	2	6.4	ns
t_{PLZ}	Output Disable from Low Level		\bar{G}	Y	2	9.5	ns
t_{PHZ}	Output Disable from High Level		\bar{G}	Y	2	5	ns

'AS244 Switching Characteristics

over recommended operating free air temperature range (Note 1)

Symbol	Parameter	Conditions	From (Input)	To (Output)	Min	Max	Units
t_{PLH}	Propagation Delay Time Low-to-High Level Output	$V_{CC} = 4.5V$ to $5.5V$ $R_1 = R_2 = 500\Omega$ $C_L = 50 pF$	A	Y	2	6.2	ns
t_{PHL}	Propagation Delay Time High-to-Low Level Output		A	Y	2	6.2	ns
t_{PZL}	Output Enable to Low Level		\bar{G}	Y	2	7.5	ns
t_{PZH}	Output Enable to High Level		\bar{G}	Y	2	9	ns
t_{PLZ}	Output Disable from Low Level		\bar{G}	Y	2	9	ns
t_{PHZ}	Output Disable from High Level		\bar{G}	Y	2	6	ns

Note 1: See Section 5 for test waveforms and output load.

Physical Dimensions inches (millimeters)

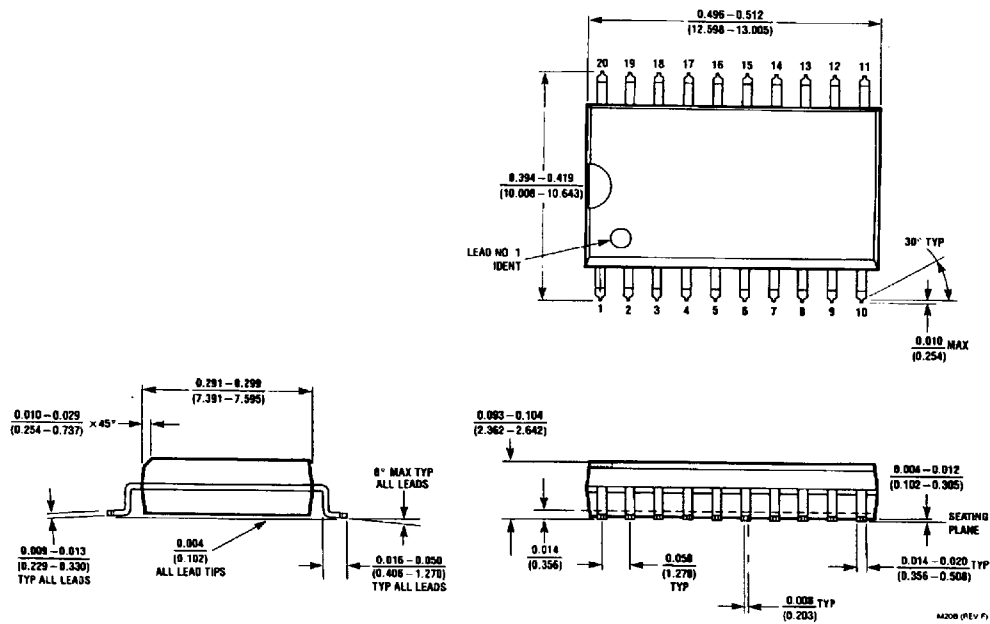

S.O. Package (M)
Order Number DM74AS240WM or DM74AS244WM
NS Package Number M20B

M20B (REV F)

1.)

<http://www.national.com>

6501122 0086036 487

Physical Dimensions inches (millimeters) (Continued)

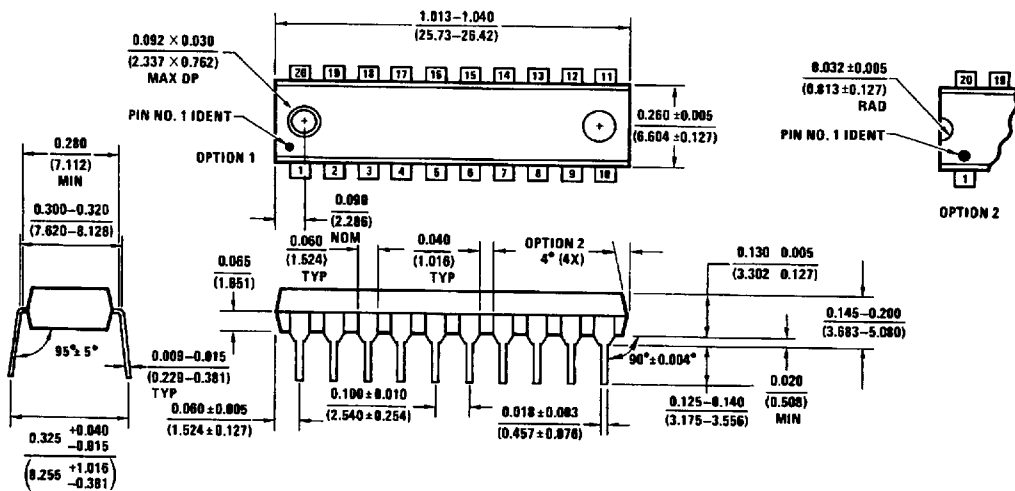

Molded Dual-In-Line Package (N)
Order Number DM74AS240N or DM74AS244N
NS Package Number N20A

N20A (REV G)

LIFE SUPPORT POLICY

NATIONAL'S PRODUCTS ARE NOT AUTHORIZED FOR USE AS CRITICAL COMPONENTS IN LIFE SUPPORT DEVICES OR SYSTEMS WITHOUT THE EXPRESS WRITTEN APPROVAL OF THE PRESIDENT OF NATIONAL SEMICONDUCTOR CORPORATION. As used herein:

1. Life support devices or systems are devices or systems which, (a) are intended for surgical implant into the body, or (b) support or sustain life, and whose failure to perform, when properly used in accordance with instructions for use provided in the labeling, can be reasonably expected to result in a significant injury to the user.
2. A critical component is any component of a life support device or system whose failure to perform can be reasonably expected to cause the failure of the life support device or system, or to affect its safety or effectiveness.

National Semiconductor Corporation
 1111 West Bardin Road
 Arlington, TX 76017
 Tel: 1(800) 272-9959
 Fax: 1(800) 737-7018
<http://www.national.com>

National Semiconductor Europe
 Fax: +49 (0) 180-530 85 86
 Email: europa.support@nsc.com
 Deutsch Tel: +49 (0) 180-530 85 85
 English Tel: +49 (0) 180-532 78 32
 Français Tel: +49 (0) 180-532 93 58
 Italiano Tel: +49 (0) 180-534 16 80

National Semiconductor Hong Kong Ltd.
 13th Floor, Straight Block,
 Ocean Centre, 5 Canton Rd.
 Tsimshatsui, Kowloon
 Hong Kong
 Tel: (852) 2737-1600
 Fax: (852) 2736-9960

National Semiconductor Japan Ltd.
 Tel: 81-043-299-2308
 Fax: 81-043-299-2408

National does not assume any responsibility for use of any circuitry described, no circuit patent licenses are implied and National reserves the right at any time without notice to change said circuitry and specifications.