

# High Current Feedthru Capacitors



## W2H/W3H Series

### GENERAL DESCRIPTION

High current feedthru capacitors are designed as a broad-band EMI filter that is specially designed to have high current handling capability. These SMT feedthru filters offer an optimized frequency response with high attenuation across a wide RF spectrum due to optimized parallel and series inductances. These W2H/W3H feedthru filters can actually replace discrete L/C filter networks.

### FEATURES

- Low parallel inductance provides significant noise reduction in circuits with operating frequencies up to 5GHz
- Broad frequency response with high attenuation
- High rated current – up to 2A for 0805 and up to 5A for 0612
- Small size – 0805 and 0612 case size
- Reeling in accordance with EIA-481

### MECHANICAL CHARACTERISTICS

- Available in EIA 0805 and 0612 cases
- Plated Tin over Nickel Barrier
- Packaged in Tape & Reel

### TYPICAL APPLICATIONS

- High current power (Vcc) lines
- PA decoupling
- DC:DC converters
- Regulators
- Power supervisory circuits

### HOW TO ORDER

<b>W2H1</b>	<b>5</b>	<b>C</b>	<b>473</b>	<b>8</b>	<b>A</b>	<b>T</b>	<b>1A</b>
<b>Size &amp; Style</b> W2H1=0805 W3H1=0612	<b>Voltage</b> 3=25v 5=50v 1=100v	<b>Dielectric</b> A=NP0 C=X7R	<b>Capacitance Code</b>	<b>Capacitance Tolerance</b> 8=+50/-20% M=±20%	<b>Failure Rate</b> A=Not Applicable	<b>Terminations</b> T=Plated Ni And Sn	<b>Packaging</b> 1A=7" Reel 4000 pcs 3A=13" Reel 4000 pcs

### PINOUT CONFIGURATION

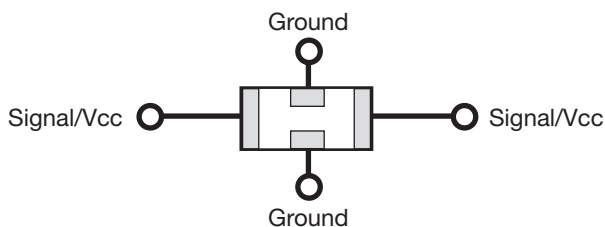

W2H1 – 0805 Style

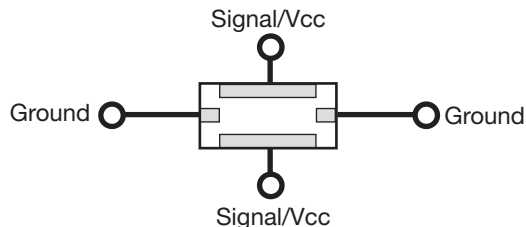

W3H1 – 0612 Style

# High Current Feedthru Capacitors



## W2H/W3H Series

### ELECTRICAL PARAMETERS

Insulation Resistance	1000 mOhms Minimum
DC Resistance	<150 mOhms
Operating Temperature	-55C to +125C

### CAPACITOR VALUES

Part Number	Size	Dielectric	Capacitance	Tolerance	Voltage	Current
W2H13C 104 8AT	0805	X7R	100,000pF	+50%, -20%	25V	2A
W2H15C 473 8AT	0805	X7R	47,000pF	+50%, -20%	50V	2A
W2H15C 223 8AT	0805	X7R	22,000pF	+50%, -20%	50V	1A
W2H15C 103 8AT	0805	X7R	10,000pF	+50%, -20%	50V	1A
W2H15C 102 8AT	0805	X7R	1,000pF	+50%, -20%	50V	1A
W2H11A 471 8AT	0805	NPO	470pF	+50%, -20%	100V	0.5A
W2H11A 221 8AT	0805	NPO	220pF	+50%, -20%	100V	0.5A
W2H11A 101 8AT	0805	NPO	100pF	+50%, -20%	100V	0.5A
W2H11A 470 8AT	0805	NPO	47pF	+50%, -20%	100V	0.5A
W2H11A 220 8AT	0805	NPO	22pF	+50%, -20%	100V	0.5A
W3H13C 104 8AT	0612	X7R	100,000pF	+50%, -20%	25V	up to 5A
W3H15C 473 8AT	0612	X7R	47,000pF	+50%, -20%	50V	up to 5A
W3H15C 223 8AT	0612	X7R	22,000pF	+50%, -20%	50V	up to 4A
W3H15C 103 8AT	0612	X7R	10,000pF	+50%, -20%	50V	up to 3A
W3H11A 471 8AT	0612	NPO	470pF	+50%, -20%	100V	up to 4A
W3H11A 221 8AT	0612	NPO	220pF	+50%, -20%	100V	up to 4A
W3H11A 101 8AT	0612	NPO	100pF	+50%, -20%	100V	up to 4A
W3H11A 470 8AT	0612	NPO	47pF	+50%, -20%	100V	up to 3A
W3H11A 220 8AT	0612	NPO	22pF	+50%, -20%	100V	up to 3A

# High Current Feedthru Capacitors



## W2H/W3H Series

### PHYSICAL DIMENSIONS AND PAD LAYOUT

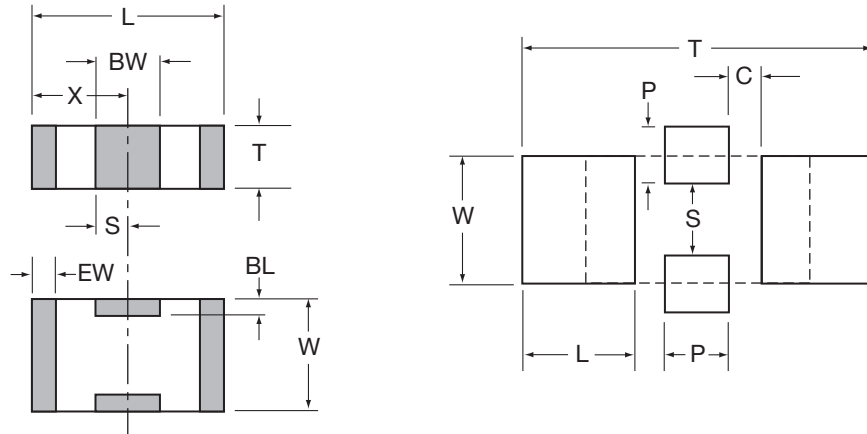

W2H1 – 0805 Style

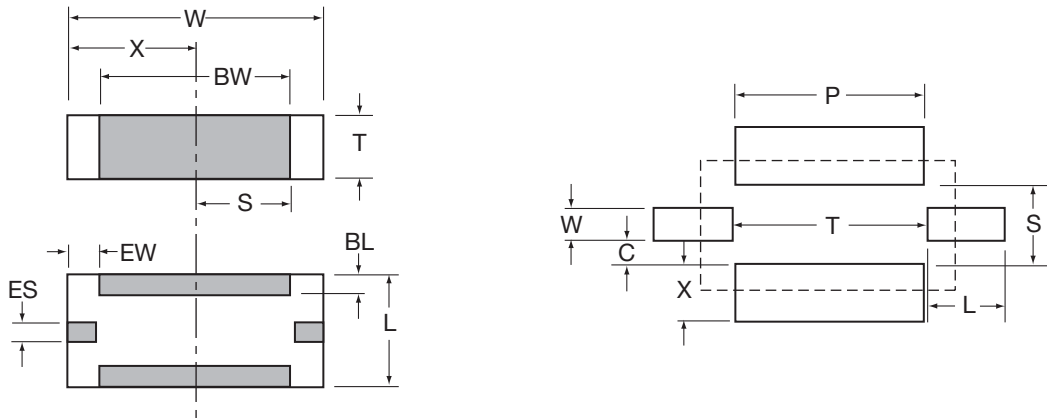

W3H1 – 0612 Style

### PHYSICAL DIMENSIONS

	L	W	T	BW	BL	ES	EW	X	S
W2H1- 0805 MM (in.)	2.01 ± 0.20 (0.079 ± 0.008)	1.25 ± 0.20 (0.049 ± 0.008)	1.14 Max. (0.045 Max.)	0.46 ± 0.10 (0.018 ± 0.004)	0.18 + 0.25 - 0.08 (0.007 + 0.010 - 0.003)	NA	0.25 ± 0.13 (0.010 ± 0.005)	1.02 ± 0.10 (0.040 ± 0.004)	0.23 ± 0.05 (0.009 ± 0.002)
W3H1- 0612 MM (in.)	1.60 ± 0.20 (0.063 ± 0.008)	3.20 ± 0.20 (0.126 ± 0.008)	1.22 Max. (0.048 Max.)	2.80 ± .127 (0.110 ± 0.005)	0.18 + 0.25 - 0.08 (0.007 + 0.010 - 0.003)	0.41 ± 0.10 (0.016 ± 0.004)	0.41 ± 0.10 (0.016 ± 0.004)	1.60 ± 0.10 (0.063 ± 0.004)	1.40 ± 0.07 (0.055 ± 0.003)

### PAD DIMENSIONS

	T	P	S	W	L	C	X
W2H1- 0805 MM (in.)	3.45 (0.136)	0.51 (0.020)	0.76 (0.030)	1.27 (0.050)	1.02 (0.040)	0.46 (0.018)	NA
W3H1- 0612 MM (in.)	2.54 (0.100)	3.05 (0.120)	1.12 (0.044)	.460 (0.018)	.610 (0.024)	.330 (0.013)	.710 (0.028)

# High Current Feedthru Capacitors



## W2H/W3H Series

### TYPICAL S21 PERFORMANCE

0805 NP0

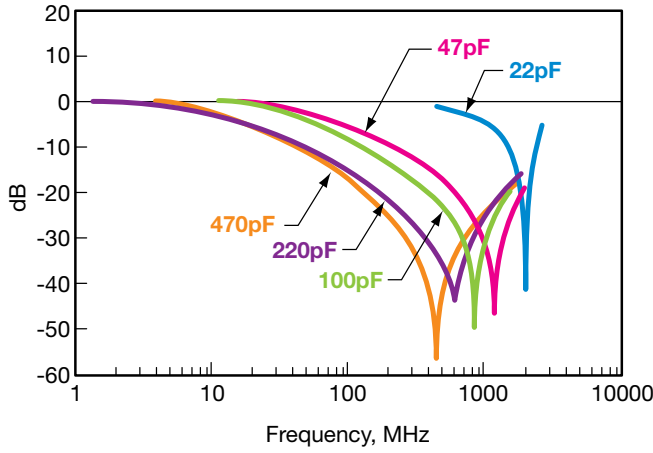

0805 X7R

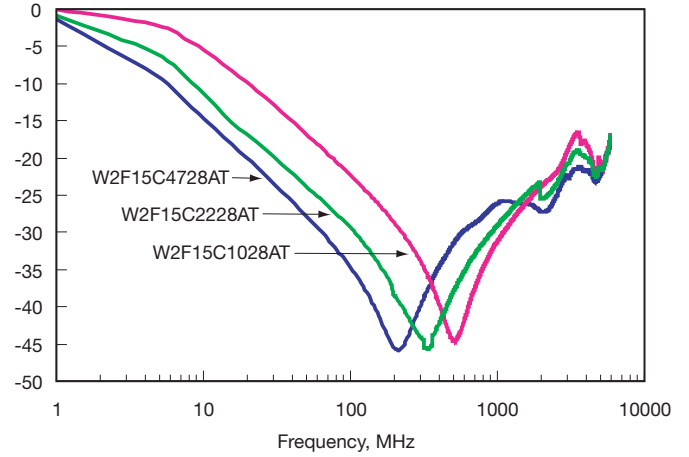

0612 NP0

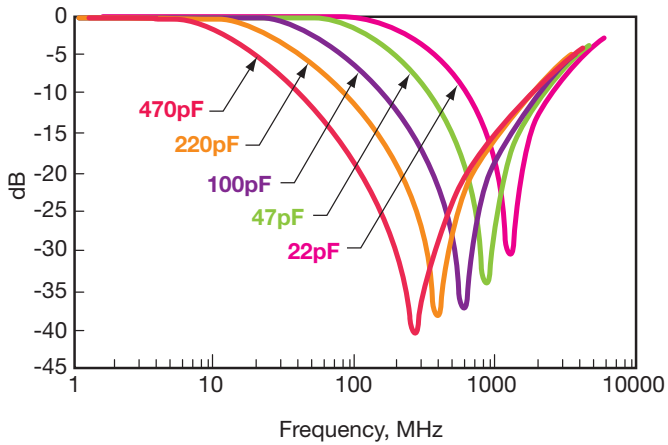

0612 X7R

