



LinearDimensions

SEMICONDUCTOR

LND081A/B/C

Up to 277VAC/347VAC/1000VAC True One-Wire Adjustable Offline Voltage Sources

GENERAL DESCRIPTION

The LND081A/B/C are single wire high voltage conductor, low cost solutions for deriving from AC offline voltages a DC output between 2.7V and 100V with mA's to 100's of mA's of current.

The LND081A are for 28VAC, 48VAC, 120VAC or 277VAC sources and include the input full bridge diodes. The LND081B is for 347VAC applications and the LND081C is for up to 1000VAC but require external full bridge diodes.

The LND081A are packaged in 8 pin EPAD SOIC packages. LND081B/C are available as bare die.

EQUIVALENT CIRCUIT

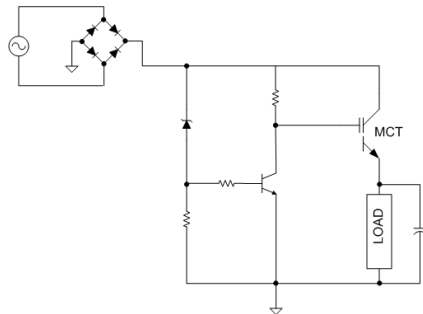

Typical Waveforms

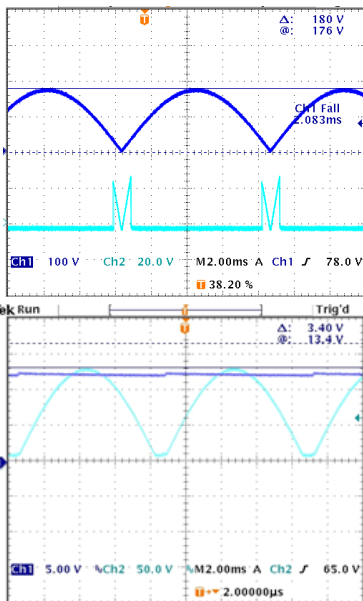

No Output Capacitor
120VAC Input – Dark Blue
Output – Light Blue

100uF Output Capacitor
85VAC Input – Light Blue
Output 12VDC – Dark Blue

FEATURES

- Adjustable offline voltage source
- 2.7V to 100V adjustable output voltage
- 100's of mA drive capability
- Lowest cost solution
- LND081A/B include full bridge diodes
- Universal Input:
 - 28VAC, 48VAC or 120VAC (A)
 - Up to 277VAC (A), 347VAC(B)
 - Up to 1000VAC (C)
- **One wire HV conductor eliminates need for multiple input wires**
- Resistor programmable output voltage against a diode threshold
- Replaces standard transformer or AC divider solutions
- Lower leakage than MOSFET, IGBT, BIPOLAR, XFMR or CAP solutions
- 8 pin EPAD-SOIC Package

APPLICATIONS

- Offline uC or PLC voltage supplies
- Industrial AC communications loop derived supplies
- Electric grid remote supplies for monitoring equipment
- Emergency lighting, monitoring equipment, industrial plant supplies
- White goods

TYPICAL APPLICATION CIRCUIT

