

Low-Voltage, Single Supply, Dual SPST, SPDT Analog Switches

The Intersil ISL43120, ISL43121, ISL43122 and ISL43210 devices are precision, bidirectional, dual analog switches designed to operate from a single +2.7V to +12V supply. Targeted applications include battery powered equipment that benefit from the devices' low power consumption (5 μ W), low leakage currents (100pA max), and fast switching speeds (t_{ON} = 28ns, t_{OFF} = 20ns). Cell phones, for example, often face ASIC functionality limitations. The number of analog input or GPIO pins may be limited and digital geometries are not well suited to analog switch performance. This family of parts may be used to "mux-in" additional functionality while reducing ASIC design risk. Some of the smallest packages are available, alleviating board space limitations, and making Intersil's newest line of low-voltage switches an ideal solution.

The ISL43120, ISL43121, ISL43122 are dual single-pole/single-throw (SPST) devices. The ISL43120 has two normally open (NO) switches; the ISL43121 has two normally closed (NC) switches; the ISL43122 has one NO and one NC switch and can be used as an SPDT. The ISL43210 is a committed SPDT, which is perfect for use in 2-to-1 multiplexer applications.

TABLE 1. FEATURES AT A GLANCE

	ISL43120	ISL43121	ISL43122	ISL43210
Number of Switches	2	2	2	1
SW 1 / SW 2	NO/NO	NC/NC	NO/NC	SPDT or 2 x 1 MUX
3.3V R_{ON}	32 Ω	32 Ω	32 Ω	32 Ω
3.3V t_{ON}/t_{OFF}	40ns/20ns	40ns/20ns	40ns/20ns	40ns /20ns
5V R_{ON}	19 Ω	19 Ω	19 Ω	19 Ω
5V t_{ON}/t_{OFF}	28ns/20ns	28ns/20ns	28ns/20ns	28ns/20ns
12V R_{ON}	11 Ω	11 Ω	11 Ω	11 Ω
12V t_{ON}/t_{OFF}	25ns/17ns	25ns/17ns	25ns/17ns	25ns/17ns
Packages	8 Ld SOT-23			6 Ld SOT-23

Related Literature

- Technical Brief TB363 "Guidelines for Handling and Processing Moisture Sensitive Surface Mount Devices (SMDs)"
- Application Note AN557 "Recommended Test Procedures for Analog Switches"

Features

- Fully specified at 12V, 5V, and 3.3V supplies for 10% tolerances
- R_{ON} resistance (R_{ON}) 19 Ω
- R_{ON} matching between channels <1 Ω
- Low charge injection 5pC (Max)
- Single supply operation +2.7V to +12V
- Low power consumption (P_D) <5 μ W
- Low leakage current 10nA
- Fast switching action
 - t_{ON} 28ns
 - t_{OFF} 20ns
- Guaranteed break-before-make (ISL43122/ISL43210 only)
- Minimum 2000V ESD protection per method 3015.7
- TTL, CMOS compatible
- Available in SOT-23 packaging
- Pb-free Available

Applications

- Battery powered, handheld, and portable equipment
 - Cellular/mobile phones
 - Pagers
 - Laptops, notebooks, palmtops
- Communications systems
 - Radios, ADSL Modems
 - PBX, PABX
- Test & measurement equipment
 - Ultrasound
 - Computerized Tomography (CT) Scanner
 - Magnetic Resonance Image (MRI)
 - Position Emission Tomography (PET) Scanner
 - Electrocardiograph
- Heads-up displays
- Audio and video switching
- Various circuits
 - +3V/+5V DACs and ADCs
 - Sample and hold circuits
 - Digital filters
 - Operational amplifier gain switching networks
 - High frequency analog switching
 - High speed multiplexing
 - Integrator reset circuits

Pinouts (Note 1)

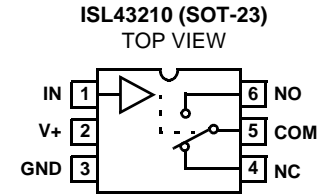
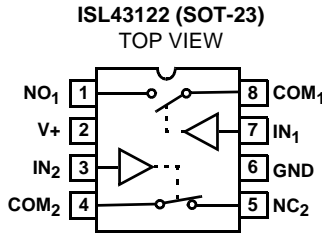
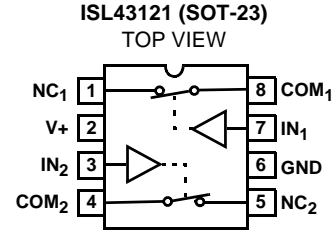
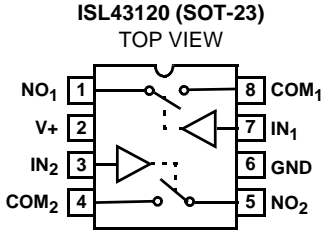

NOTE:

1. Switches Shown for Logic "0" Input.

Truth Table

LOGIC	ISL43120	ISL43121	ISL43122		ISL43210	
	SW 1, 2	SW 1, 2	SW 1	SW 2	PIN NC	PIN NO
0	OFF	ON	OFF	ON	ON	OFF
1	ON	OFF	ON	OFF	OFF	ON

NOTE: Logic "0" ≤0.8V. Logic "1" ≥2.4V.

Pin Descriptions

PIN	FUNCTION
V+	System Power Supply Input (+2.7V to +12V)
GND	Ground Connection
IN	Digital Control Input
COM	Analog Switch Common Pin
NO	Analog Switch Normally Open Pin
NC	Analog Switch Normally Closed Pin
N.C.	No Internal Connection

Ordering Information

PART NO. (BRAND)	TEMP. RANGE (°C)	PACKAGE	PKG. DWG. #
ISL43120IH-T (120I)	-40 to 85	8 Ld SOT-23 Tape and Reel	P8.064
ISL43121IH-T (121I)	-40 to 85	8 Ld SOT-23 Tape and Reel	P8.064
ISL43122IH-T (122I)	-40 to 85	8 Ld SOT-23 Tape and Reel	P8.064
ISL43122IHZ-T (122I) (Note)	-40 to 85	8 Ld SOT-23 Tape and Reel (Pb-free)	P8.064
ISL43210IH-T (123I)	-40 to 85	6 Ld SOT-23 Tape and Reel	P6.064
ISL43210IHZ-T (123I) (Note)	-40 to 85	6 Ld SOT-23 Tape and Reel (Pb-free)	P6.064

NOTE: Intersil Pb-free products employ special Pb-free material sets; molding compounds/die attach materials and 100% matte tin plate termination finish, which is compatible with both SnPb and Pb-free soldering operations. Intersil Pb-free products are MSL classified at Pb-free peak reflow temperatures that meet or exceed the Pb-free requirements of IPC/JEDEC J Std-020B.

ISL43120, ISL43121, ISL43122, ISL43210

Absolute Maximum Ratings

V+ to GND	-0.3 to 15V
Input Voltages	
IN (Note 2)	-0.3 to ((V+) + 0.3V)
NO, NC (Note 2)	-0.3 to ((V+) + 0.3V)
Output Voltages	
COM (Note 2)	-0.3 to ((V+) + 0.3V)
Continuous Current (Any Terminal)	30mA
Peak Current NO, NC, or COM	
(Pulsed 1ms, 10% Duty Cycle, Max)	40mA
ESD Rating (Per MIL-STD-883 Method 3015)	>2kV

Thermal Information

Thermal Resistance (Typical, Note 3)	θ_{JA} (°C/W)
6 Ld SOT-23 Package	230
8 Ld SOT-23 Package	215
Maximum Junction Temperature (Plastic Package)	150°C
Moisture Sensitivity (See Technical Brief TB363)	
Other Package	Level 1
8 Ld SOT-23 Package	Level 2
Maximum Storage Temperature Range	-65°C to 150°C
Maximum Lead Temperature (Soldering 10s)	300°C
(Lead Tips Only)	

Operating Conditions

Temperature Range	
ISL43XXIH-T	-40°C to 85°C

CAUTION: Stresses above those listed in "Absolute Maximum Ratings" may cause permanent damage to the device. This is a stress only rating and operation of the device at these or any other conditions above those indicated in the operational sections of this specification is not implied.

NOTES:

- Signals on NC, NO, COM, or IN exceeding V+ or GND are clamped by internal diodes. Limit forward diode current to maximum current ratings.
- θ_{JA} is measured with the component mounted on a low effective thermal conductivity test board in free air. See Tech Brief TB379 for details.

Electrical Specifications - 5V Supply

Test Conditions: V+ = +4.5V to +5.5V, GND = 0V, V_{INH} = 2.4V, V_{INL} = 0.8V (Note 4), Unless Otherwise Specified

PARAMETER	TEST CONDITIONS	TEMP (°C)	(NOTE 5) MIN	TYP	(NOTE 5) MAX	UNITS
ANALOG SWITCH CHARACTERISTICS						
Analog Signal Range, V _{ANALOG}		Full	0	-	V+	V
ON Resistance, R _{ON}	V+ = 4.5V, I _{COM} = 1.0mA, V _{NO} or V _{NC} = 3.5V (See Figure 5)	25	-	19	30	Ω
		Full	-	23	40	Ω
R _{ON} Matching Between Channels, ΔR _{ON}	V+ = 5V, I _{COM} = 1.0mA, V _{NO} or V _{NC} = 3.5V	25	-	0.8	2	Ω
		Full	-	1	4	Ω
R _{ON} Flatness, R _{FLAT(ON)}	V+ = 5V, I _{COM} = 1.0mA, V _{NO} or V _{NC} = 1V, 2V, 3V	Full	-	7	8	Ω
NO or NC OFF Leakage Current, I _{NO(OFF)} or I _{NC(OFF)}	V+ = 5.5V, V _{COM} = 1V, 4.5V, V _{NO} or V _{NC} = 4.5V, 1V (Note 6)	25	-0.1	0.01	0.1	nA
		Full	-5	-	5	nA
COM OFF Leakage Current, I _{COM(OFF)}	V+ = 5.5V, V _{COM} = 4.5V, 1V, V _{NO} or V _{NC} = 1V, 4.5V (Note 6)	25	-0.1	-	0.1	nA
		Full	-5	-	5	nA
COM ON Leakage Current, I _{COM(ON)}	V+ = 5.5V, V _{COM} = 1V, 4.5V, or V _{NO} or V _{NC} = 1V, 4.5V, or Floating (Note 6)	25	-0.2	-	0.2	nA
		Full	-10	-	10	nA
DYNAMIC CHARACTERISTICS						
Turn-ON Time, t _{ON}	V _{NO} or V _{NC} = 3V, R _L = 1kΩ, C _L = 35pF, V _{IN} = 0 to 3V (See Figure 1)	25	-	28	75	ns
		Full	-	40	150	ns
Turn-OFF Time, t _{OFF}	V _{NO} or V _{NC} = 3V, R _L = 1kΩ, C _L = 35pF, V _{IN} = 0 to 3V (See Figure 1)	25	-	20	50	ns
		Full	-	30	100	ns
Break-Before-Make Time Delay (ISL43122, ISL43210), t _D	R _L = 300Ω, C _L = 35pF, V _{NO} = V _{NC} = 3V, V _{IN} = 0 to 3V (See Figure 3)	Full	3	10	-	ns
Charge Injection, Q	C _L = 1.0nF, V _G = 0V, R _G = 0Ω (See Figure 2)	25	-	3	5	pC
OFF Isolation	R _L = 50Ω, C _L = 5pF, f = 1MHz (See Figure 4)	25	-	76	-	dB
Crosstalk (Channel-to-Channel)	R _L = 50Ω, C _L = 5pF, f = 1MHz (See Figure 6)	25	-	-105	-	dB
Power Supply Rejection Ratio	R _L = 50Ω, C _L = 5pF, f = 1MHz	25	-	60	-	dB
NO or NC OFF Capacitance, C _{OFF}	f = 1MHz, V _{NO} or V _{NC} = V _{COM} = 0V (See Figure 7)	25	-	8	-	pF
COM OFF Capacitance, C _{COM(OFF)}	f = 1MHz, V _{NO} or V _{NC} = V _{COM} = 0V (See Figure 7)	25	-	8	-	pF

ISL43120, ISL43121, ISL43122, ISL43210

Electrical Specifications - 5V Supply

Test Conditions: $V_+ = +4.5V$ to $+5.5V$, $GND = 0V$, $V_{INH} = 2.4V$, $V_{INL} = 0.8V$ (Note 4), Unless Otherwise Specified **(Continued)**

PARAMETER	TEST CONDITIONS	TEMP (°C)	(NOTE 5) MIN	TYP	(NOTE 5) MAX	UNITS
COM ON Capacitance, $C_{COM(ON)}$	$f = 1MHz$, V_{NO} or $V_{NC} = V_{COM} = 0V$ (See Figure 7), ISL43120, ISL43121, ISL43122	25	-	21	-	pF
	$f = 1MHz$, V_{NO} or $V_{NC} = V_{COM} = 0V$ (See Figure 7), ISL43210	25	-	28	-	pF
POWER SUPPLY CHARACTERISTICS						
Power Supply Range		Full	2.7	-	12	V
Positive Supply Current, I_+	$V_+ = 5.5V$, $V_{IN} = 0V$ or V_+ , all channels on or off	Full	-1	0.0001	1	μA
DIGITAL INPUT CHARACTERISTICS						
Input Voltage Low, V_{INL}		Full	-	-	0.8	V
Input Voltage High, V_{INH}		Full	2.4	-	-	V
Input Current, I_{INH} , I_{INL}	$V_+ = 5.5V$, $V_{IN} = 0V$ or V_+	Full	-1	-	1	μA

NOTES:

4. V_{IN} = input voltage to perform proper function.
5. The algebraic convention, whereby the most negative value is a minimum and the most positive a maximum, is used in this data sheet.
6. Leakage parameter is 100% tested at high temp, and guaranteed by correlation at 25°C.

Electrical Specifications - 3.3V Supply

Test Conditions: $V_+ = +3.0V$ to $+3.6V$, $GND = 0V$, $V_{INH} = 2.4V$, $V_{INL} = 0.8V$ (Note 4), Unless Otherwise Specified

PARAMETER	TEST CONDITIONS	TEMP (°C)	(NOTE 5) MIN	TYP	(NOTE 5) MAX	UNITS
ANALOG SWITCH CHARACTERISTICS						
Analog Signal Range, V_{ANALOG}		Full	0	-	V_+	V
ON Resistance, R_{ON}	$V_+ = 3V$, $I_{COM} = 1.0mA$, V_{NO} or $V_{NC} = 1.5V$	25	-	32	50	Ω
		Full	-	40	60	Ω
R_{ON} Matching Between Channels, ΔR_{ON}	$V_+ = 3.3V$, $I_{COM} = 1.0mA$, V_{NO} or $V_{NC} = 1.5V$	25	-	0.8	2	Ω
		Full	-	1	4	Ω
R_{ON} Flatness, $R_{FLAT(ON)}$	$V_+ = 3.3V$, $I_{COM} = 1.0mA$, V_{NO} or $V_{NC} = 0.5V, 1V, 1.5V$	25	-	6	8	Ω
		Full	-	7	12	Ω
NO or NC OFF Leakage Current, $I_{NO(OFF)}$ or $I_{NC(OFF)}$	$V_+ = 3.6V$, $V_{COM} = 1V, 3V$, V_{NO} or $V_{NC} = 3V, 1V$ (Note 6)	25	-0.1	0.01	0.1	nA
		Full	-5	-	5	nA
COM OFF Leakage Current, $I_{COM(OFF)}$	$V_+ = 3.6V$, $V_{COM} = 3V, 1V$, V_{NO} or $V_{NC} = 1V, 3V$ (Note 6)	25	-0.1	0.01	0.1	nA
		Full	-5	-	5	nA
COM ON Leakage Current, $I_{COM(ON)}$	$V_+ = 3.6V$, $V_{COM} = 1V, 3V$, or V_{NO} or $V_{NC} = 1V, 3V$, or floating (Note 6)	25	-0.2	-	0.2	nA
		Full	-10	-	10	nA
DYNAMIC CHARACTERISTICS						
Turn-ON Time, t_{ON}	V_{NO} or $V_{NC} = 1.5V$, $R_L = 1k\Omega$, $C_L = 35pF$, $V_{IN} = 0$ to $3V$	25	-	40	120	ns
		Full	-	60	200	ns
Turn-OFF Time, t_{OFF}	V_{NO} or $V_{NC} = 1.5V$, $R_L = 1k\Omega$, $C_L = 35pF$, $V_{IN} = 0$ to $3V$	25	-	20	50	ns
		Full	-	30	120	ns
Break-Before-Make Time Delay (ISL43122, ISL43210), t_D	$R_L = 300\Omega$, $C_L = 35pF$, V_{NO} or $V_{NC} = 1.5V$, $V_{IN} = 0$ to $3V$	Full	3	20	-	ns
Charge Injection, Q	$C_L = 1.0nF$, $V_G = 0V$, $R_G = 0\Omega$	25	-	1	5	pC
OFF Isolation	$R_L = 50\Omega$, $C_L = 5pF$, $f = 1MHz$	25	-	76	-	dB
Crosstalk (Channel-to-Channel)		25	-	-105	-	dB
Power Supply Rejection Ratio	$R_L = 50\Omega$, $C_L = 5pF$, $f = 1MHz$	25	-	56	-	dB
NO or NC OFF Capacitance, C_{OFF}	$f = 1MHz$, V_{NO} or $V_{NC} = V_{COM} = 0V$	25	-	8	-	pF

ISL43120, ISL43121, ISL43122, ISL43210

Electrical Specifications - 3.3V Supply

Test Conditions: $V_+ = +3.0V$ to $+3.6V$, $GND = 0V$, $V_{INH} = 2.4V$, $V_{INL} = 0.8V$ (Note 4), Unless Otherwise Specified **(Continued)**

PARAMETER	TEST CONDITIONS	TEMP (°C)	(NOTE 5) MIN	TYP	(NOTE 5) MAX	UNITS
COM OFF Capacitance, $C_{COM(OFF)}$	$f = 1MHz$, V_{NO} or $V_{NC} = V_{COM} = 0V$	25	-	8	-	pF
COM ON Capacitance, $C_{COM(ON)}$	$f = 1MHz$, V_{NO} or $V_{NC} = V_{COM} = 0V$, ISL43120, ISL43121, ISL43122	25	-	21	-	pF
	$f = 1MHz$, V_{NO} or $V_{NC} = V_{COM} = 0V$, ISL43210	25	-	28	-	pF
POWER SUPPLY CHARACTERISTICS						
Positive Supply Current, I_+	$V_+ = 3.6V$, $V_{IN} = 0V$ or V_+ , all channels on or off	Full	-1	-	1	μA
DIGITAL INPUT CHARACTERISTICS						
Input Voltage Low, V_{INL}		Full	-	-	0.8	V
Input Voltage High, V_{INH}		Full	2.4	-	-	V
Input Current, I_{INH} , I_{INL}	$V_+ = 3.6V$, $V_{IN} = 0V$ or V_+	Full	-1	-	1	μA

Electrical Specifications - 12V Supply

Test Conditions: $V_+ = +10.8V$ to $+13V$, $GND = 0V$, $V_{INH} = 4V$, $V_{INL} = 0.8V$ (Note 4), Unless Otherwise Specified

PARAMETER	TEST CONDITIONS	TEMP (°C)	(NOTE 5) MIN	TYP	(NOTE 5) MAX	UNITS
ANALOG SWITCH CHARACTERISTICS						
Analog Signal Range, V_{ANALOG}		Full	0	-	V_+	V
ON Resistance, R_{ON}	$V_+ = 10.8V$, $I_{COM} = 1.0mA$, V_{NO} or $V_{NC} = 10V$	25	-	11	20	Ω
		Full	-	15	25	Ω
R_{ON} Matching Between Channels, ΔR_{ON}	$V_+ = 12V$, $I_{COM} = 1.0mA$, V_{NO} or $V_{NC} = 10V$	25	-	0.8	2	Ω
		Full	-	1	4	Ω
R_{ON} Flatness, $R_{FLAT(ON)}$	$V_+ = 12V$, $I_{COM} = 1.0mA$, V_{NO} or $V_{NC} = 3V, 6V, 9V$	25	-	1	4	Ω
		Full	-	-	6	Ω
NO or NC OFF Leakage Current, $I_{NO(OFF)}$ or $I_{NC(OFF)}$	$V_+ = 13V$, $V_{COM} = 1V, 12V$, V_{NO} or $V_{NC} = 12V, 1V$ (Note 6)	25	-0.1	0.01	0.1	nA
		Full	-5	-	5	nA
COM OFF Leakage Current, $I_{COM(OFF)}$	$V_+ = 13V$, $V_{COM} = 12V, 1V$, V_{NO} or $V_{NC} = 1V, 12V$ (Note 6)	25	-0.1	0.01	0.1	nA
		Full	-5	-	5	nA
COM ON Leakage Current, $I_{COM(ON)}$	$V_+ = 13V$, $V_{COM} = 1V, 12V$, or V_{NO} or $V_{NC} = 1V, 12V$, or floating (Note 6)	25	-0.2	-	0.2	nA
		Full	-10	-	10	nA
DYNAMIC CHARACTERISTICS						
Turn-ON Time, t_{ON}	V_{NO} or $V_{NC} = 10V$, $R_L = 1k\Omega$, $C_L = 35pF$, $V_{IN} = 0$ to $4V$	25	-	25	35	ns
		Full	-	35	55	ns
Turn-OFF Time, t_{OFF}	V_{NO} or $V_{NC} = 10V$, $R_L = 1k\Omega$, $C_L = 35pF$, $V_{IN} = 0$ to $4V$	25	-	17	30	ns
		Full	-	26	50	ns
Break-Before-Make Time Delay (ISL43122, ISL43210), t_D	$R_L = 300\Omega$, $C_L = 35pF$, V_{NO} or $V_{NC} = 10V$, $V_{IN} = 0$ to $4V$	Full	0	2	-	ns
Charge Injection, Q	$C_L = 1.0nF$, $V_G = 0V$, $R_G = 0\Omega$	25	-	5	15	pC
OFF Isolation	$R_L = 50\Omega$, $C_L = 5pF$, $f = 1MHz$	25	-	76	-	dB
Crosstalk (Channel-to-Channel)		25	-	-105	-	dB
Power Supply Rejection Ratio	$R_L = 50\Omega$, $C_L = 5pF$, $f = 1MHz$	25	-	63	-	dB
NO or NC OFF Capacitance, C_{OFF}	$f = 1MHz$, V_{NO} or $V_{NC} = V_{COM} = 0V$	25	-	8	-	pF
COM OFF Capacitance, $C_{COM(OFF)}$	$f = 1MHz$, V_{NO} or $V_{NC} = V_{COM} = 0V$	25	-	8	-	pF
COM ON Capacitance, $C_{COM(ON)}$	$f = 1MHz$, V_{NO} or $V_{NC} = V_{COM} = 0V$, ISL43120, ISL43121, ISL43122	25	-	21	-	pF
	$f = 1MHz$, V_{NO} or $V_{NC} = V_{COM} = 0V$, ISL43210	25	-	28	-	pF

Electrical Specifications - 12V Supply

Test Conditions: $V_+ = +10.8V$ to $+13V$, $GND = 0V$, $V_{INH} = 4V$, $V_{INL} = 0.8V$ (Note 4), Unless Otherwise Specified **(Continued)**

PARAMETER	TEST CONDITIONS	TEMP (°C)	(NOTE 5) MIN	TYP	(NOTE 5) MAX	UNITS
POWER SUPPLY CHARACTERISTICS						
Positive Supply Current, I_+	$V_+ = 13V$, $V_{IN} = 0V$ or V_+ , all channels on or off	Full	-1	-	1	μA
DIGITAL INPUT CHARACTERISTICS						
Input Voltage Low, V_{INL}		Full	-	-	0.8	V
Input Voltage High, V_{INH}		Full	4	3	-	V
Input Current, I_{INH} , I_{INL}	$V_+ = 13V$, $V_{IN} = 0V$ or V_+	Full	-1	-	1	μA

Test Circuits and Waveforms

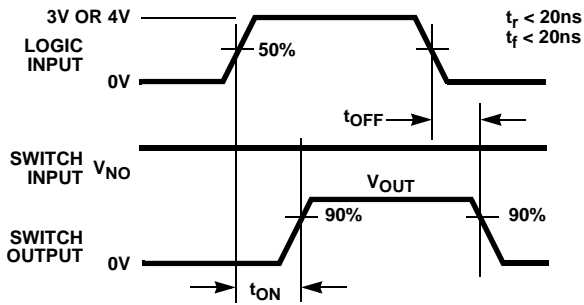

Logic input waveform is inverted for switches that have the opposite logic sense.

FIGURE 1A. MEASUREMENT POINTS

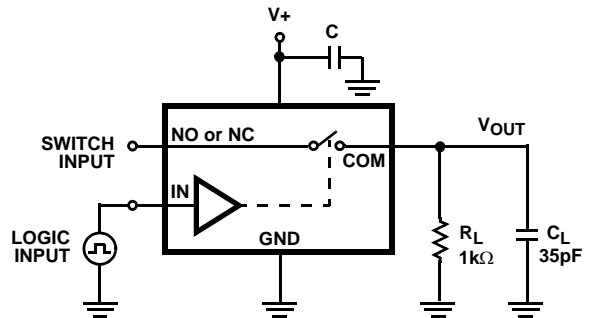

Repeat test for all switches. C_L includes fixture and stray capacitance.

$$V_{OUT} = V_{(NO\ or\ NC)} \frac{R_L}{R_L + R_{(ON)}}$$

FIGURE 1B. TEST CIRCUIT

FIGURE 1. SWITCHING TIMES

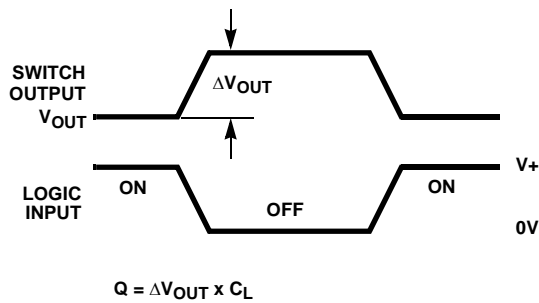

FIGURE 2A. MEASUREMENT POINTS

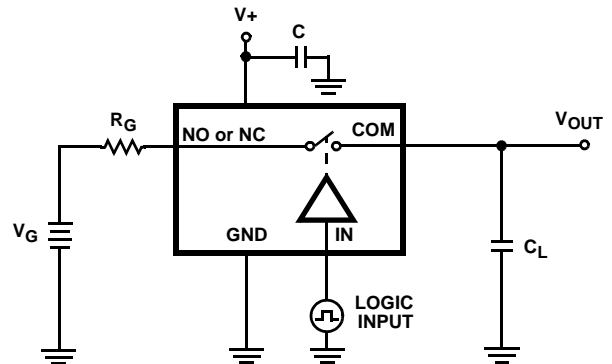

FIGURE 2B. TEST CIRCUIT

FIGURE 2. CHARGE INJECTION

Test Circuits and Waveforms (Continued)

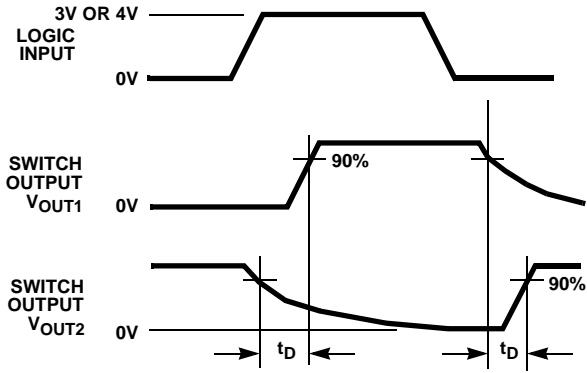
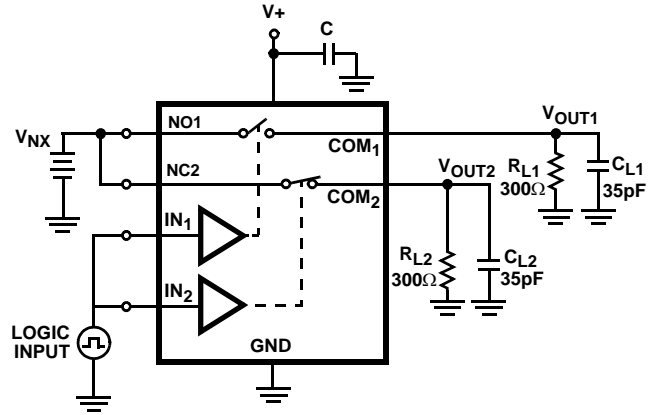

FIGURE 3A. MEASUREMENT POINTS (ISL43122 ONLY)



C_L includes fixture and stray capacitance.

FIGURE 3B. TEST CIRCUIT (ISL43122 ONLY)

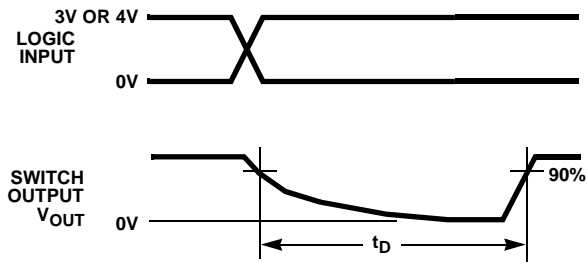
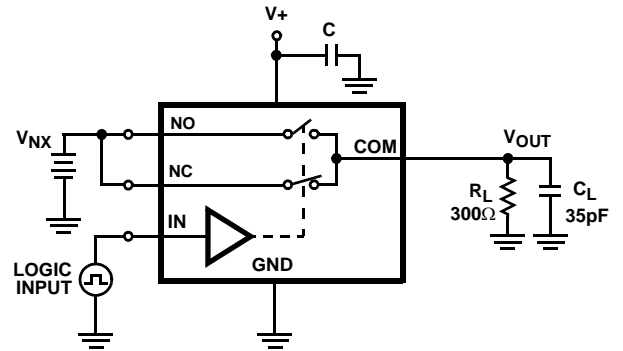

FIGURE 3C. MEASUREMENT POINTS (ISL43210 ONLY)



C_L includes fixture and stray capacitance.

FIGURE 3D. TEST CIRCUIT (ISL43210 ONLY)

FIGURE 3. BREAK-BEFORE-MAKE TIME

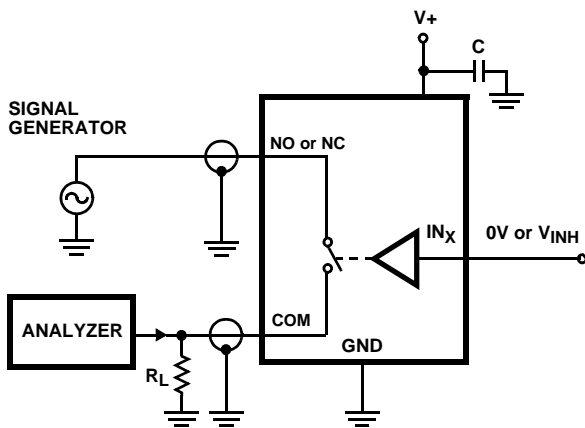

FIGURE 4. OFF ISOLATION TEST CIRCUIT

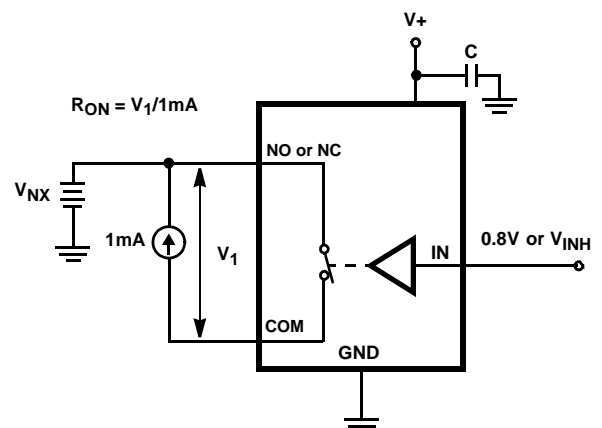

FIGURE 5. R_{ON} TEST CIRCUIT

Test Circuits and Waveforms (Continued)

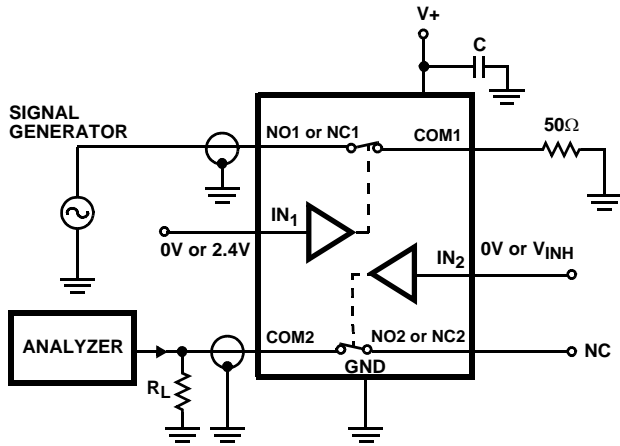

FIGURE 6. CROSSTALK TEST CIRCUIT

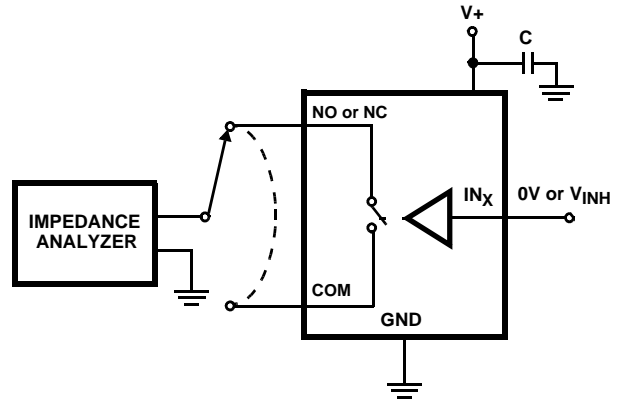

FIGURE 7. CAPACITANCE TEST CIRCUIT

Detailed Description

The ISL43120–ISL43122 and ISL43210 bidirectional, dual analog switches offer precise switching capability from a single 2.7V to 12V supply with low on-resistance (19Ω) and high speed operation ($t_{ON} = 28\text{ns}$, $t_{OFF} = 20\text{ns}$). The devices are especially well suited to portable battery powered equipment thanks to the low operating supply voltage (2.7V), low power consumption (5μW), low leakage currents (100pA max), and the tiny SOT-23 packaging. High frequency applications also benefit from the wide bandwidth, and the very high off isolation and crosstalk rejection.

Supply Sequencing And Overvoltage Protection

With any CMOS device, proper power supply sequencing is required to protect the device from excessive input currents which might permanently damage the IC. All I/O pins contain ESD protection diodes from the pin to V+ and GND (see Figure 8). To prevent forward biasing these diodes, V+ must be applied before any input signals, and input signal voltages must remain between V+ and GND. If these conditions cannot be guaranteed, then one of the following two protection methods should be employed.

Logic inputs can easily be protected by adding a 1kΩ resistor in series with the input (see Figure 8). The resistor limits the input current below the threshold that produces permanent damage, and the sub-microamp input current produces an insignificant voltage drop during normal operation.

Adding a series resistor to the switch input defeats the purpose of using a low R_{ON} switch, so two small signal diodes can be added in series with the supply pins to provide overvoltage protection for all pins (see Figure 8). These additional diodes limit the analog signal from 1V below V+ to 1V above GND. The low leakage current performance is

unaffected by this approach, but the switch resistance may increase, especially at low supply voltages.

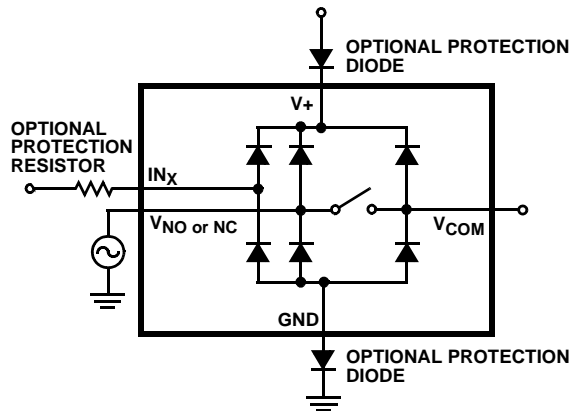

FIGURE 8. OVERVOLTAGE PROTECTION

Power-Supply Considerations

The ISL43XXX construction is typical of most CMOS analog switches, except that they have only two supply pins: V+ and GND. V+ and GND drive the internal CMOS switches and set their analog voltage limits. Unlike switches with a 13V maximum supply voltage, the ISL43XXX 15V maximum supply voltage provides plenty of room for the 10% tolerance of 12V supplies, as well as room for overshoot and noise spikes.

The minimum recommended supply voltage is 2.7V. It is important to note that the input signal range, switching times, and on-resistance degrade at lower supply voltages. Refer to the electrical specification tables and Typical Performance curves for details.

V+ and GND also power the internal logic and level shifter. The level shifter convert the input logic levels to switched V+ and GND signals to drive the analog switch gate terminals.

This family of switches cannot be operated with bipolar supplies, because the input switching point becomes negative in this configuration.

Logic-Level Thresholds

This switch family is TTL compatible (0.8V and 2.4V) over a supply range of 3V to 11V (see Figure 15). At 12V the V_{IH} level is about 2.5V. This is still below the TTL guaranteed high output minimum level of 2.8V, but noise margin is reduced. For best results with a 12V supply, use a logic family the provides a V_{OH} greater than 3V.

The digital input stages draw supply current whenever the digital input voltage is not at one of the supply rails. Driving the digital input signals from GND to V+ with a fast transition time minimizes power dissipation.

High-Frequency Performance

In 50Ω systems, signal response is reasonably flat even past 300MHz (see Figure 16). Figure 16 also illustrates that the frequency response is very consistent over a wide V+ range, and for varying analog signal levels.

An OFF switch acts like a capacitor and passes higher frequencies with less attenuation, resulting in signal feedthrough from a switch’s input to its output. Off Isolation is the resistance to this feedthrough, while Crosstalk

indicates the amount of feedthrough from one switch to another. Figure 17 details the high Off Isolation and Crosstalk rejection provided by this family. At 10MHz, Off Isolation is about 50dB in 50Ω systems, decreasing approximately 20dB per decade as frequency increases. Higher load impedances decrease Off Isolation and Crosstalk rejection due to the voltage divider action of the switch OFF impedance and the load impedance.

Leakage Considerations

Reverse ESD protection diodes are internally connected between each analog-signal pin and both V+ and GND. One of these diodes conducts if any analog signal exceeds V+ or GND.

Virtually all the analog leakage current comes from the ESD diodes to V+ or GND. Although the ESD diodes on a given signal pin are identical and therefore fairly well balanced, they are reverse biased differently. Each is biased by either V+ or GND and the analog signal. This means their leakages will vary as the signal varies. The difference in the two diode leakages to the V+ and GND pins constitutes the analog-signal-path leakage current. All analog leakage current flows between each pin and one of the supply terminals, not to the other switch terminal. This is why both sides of a given switch can show leakage currents of the same or opposite polarity. There is no connection between the analog signal paths and V+ or GND.

Typical Performance Curves T_A = 25°C, Unless Otherwise Specified

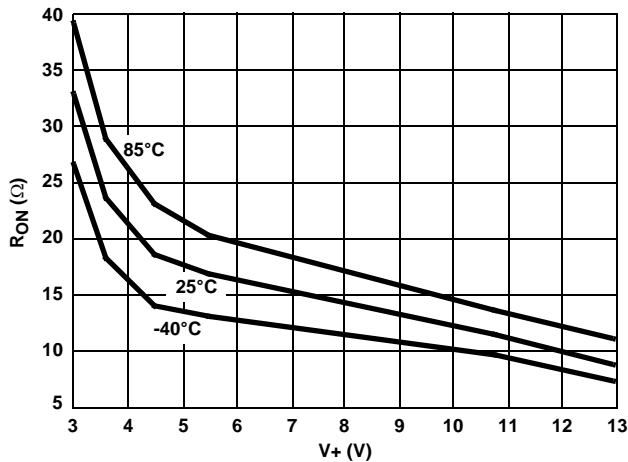

FIGURE 9. ON RESISTANCE vs SUPPLY VOLTAGE

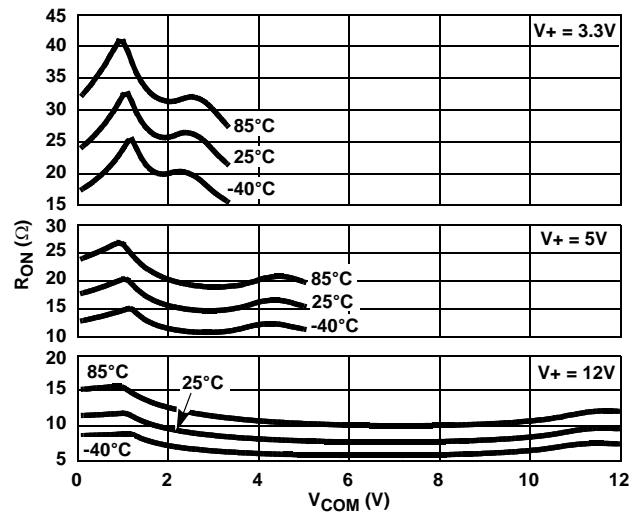

FIGURE 10. ON RESISTANCE vs SWITCH VOLTAGE

Typical Performance Curves $T_A = 25^\circ\text{C}$, Unless Otherwise Specified (Continued)

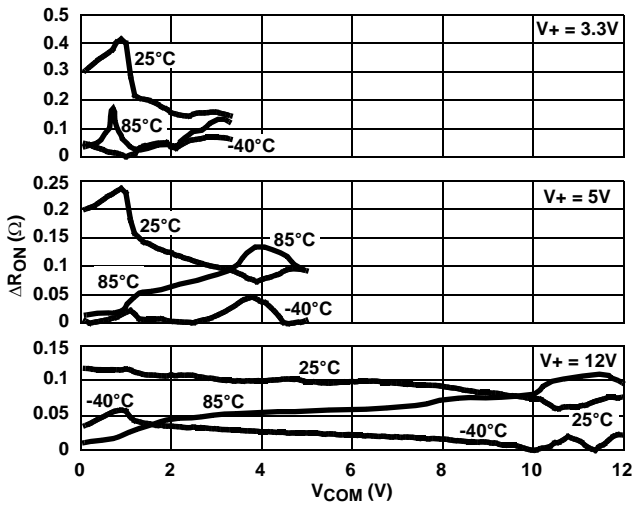

FIGURE 11. R_{ON} MATCH vs SWITCH VOLTAGE

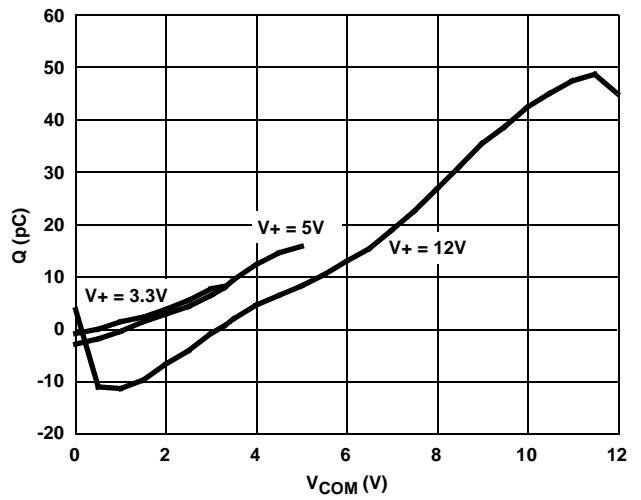

FIGURE 12. CHARGE INJECTION vs SWITCH VOLTAGE

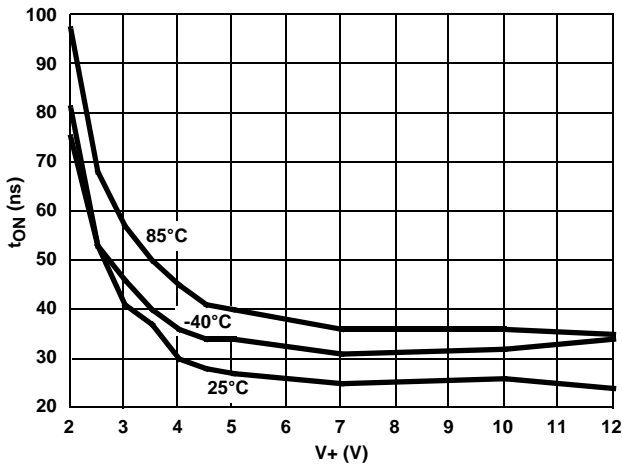

FIGURE 13. TURN - ON TIME vs SUPPLY VOLTAGE

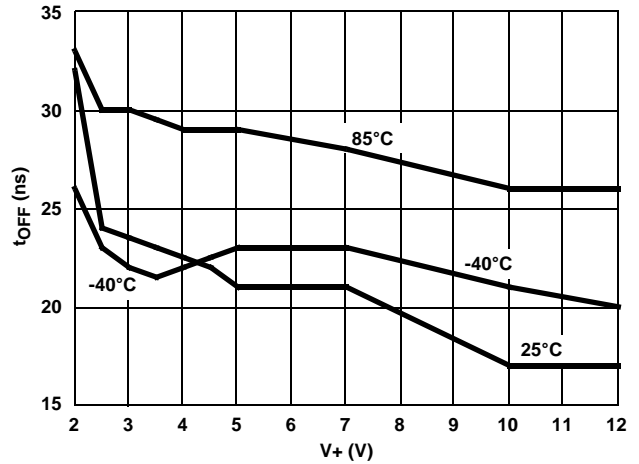

FIGURE 14. TURN - OFF TIME vs SUPPLY VOLTAGE

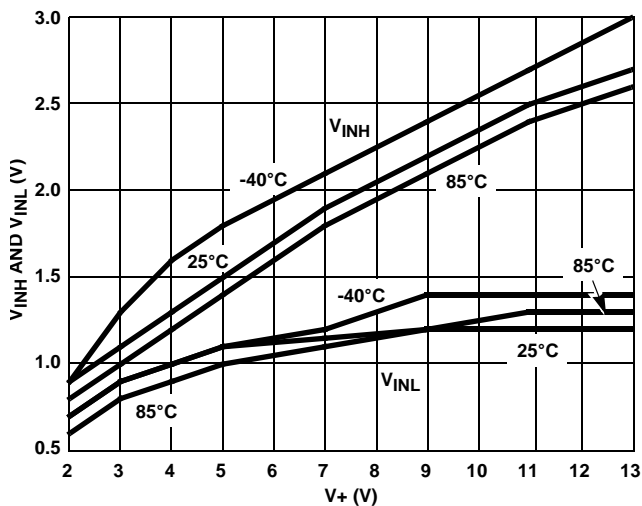

FIGURE 15. DIGITAL SWITCHING POINT vs SUPPLY VOLTAGE

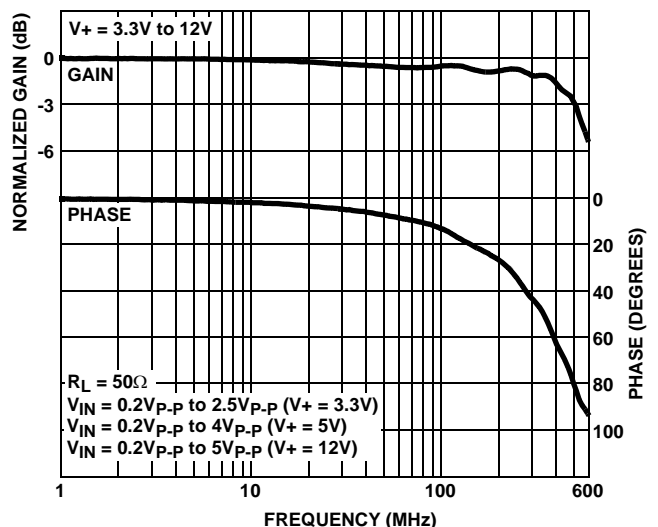

FIGURE 16. FREQUENCY RESPONSE

Typical Performance Curves $T_A = 25^\circ\text{C}$, Unless Otherwise Specified (Continued)

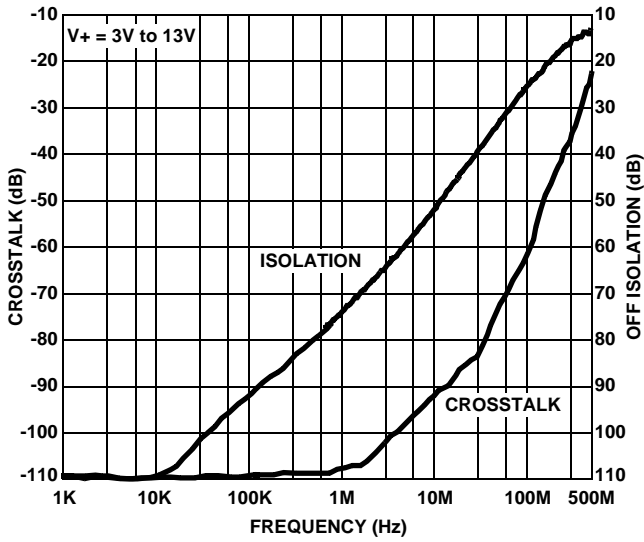

FIGURE 17. CROSSTALK AND OFF ISOLATION

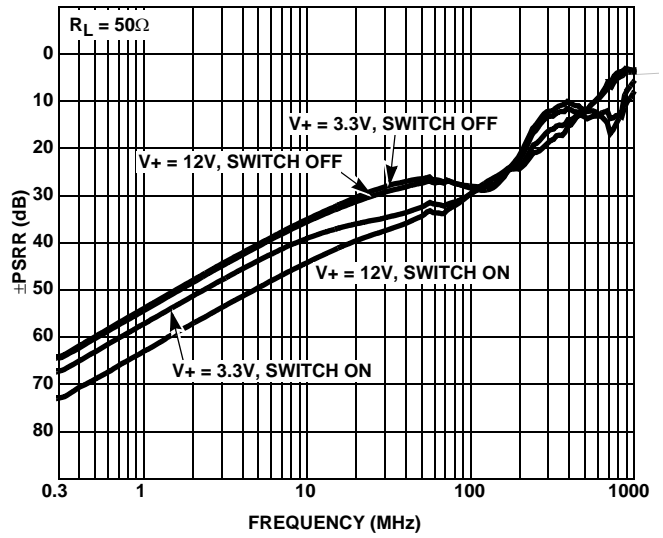

FIGURE 18. $\pm\text{PSRR}$ vs FREQUENCY

Die Characteristics

SUBSTRATE POTENTIAL (POWERED UP):

GND

TRANSISTOR COUNT:

- ISL43120: 66
- ISL43121: 66
- ISL43122: 66
- ISL43210: 58

PROCESS:

Si Gate CMOS

Small Outline Transistor Plastic Packages (SOT23-6)

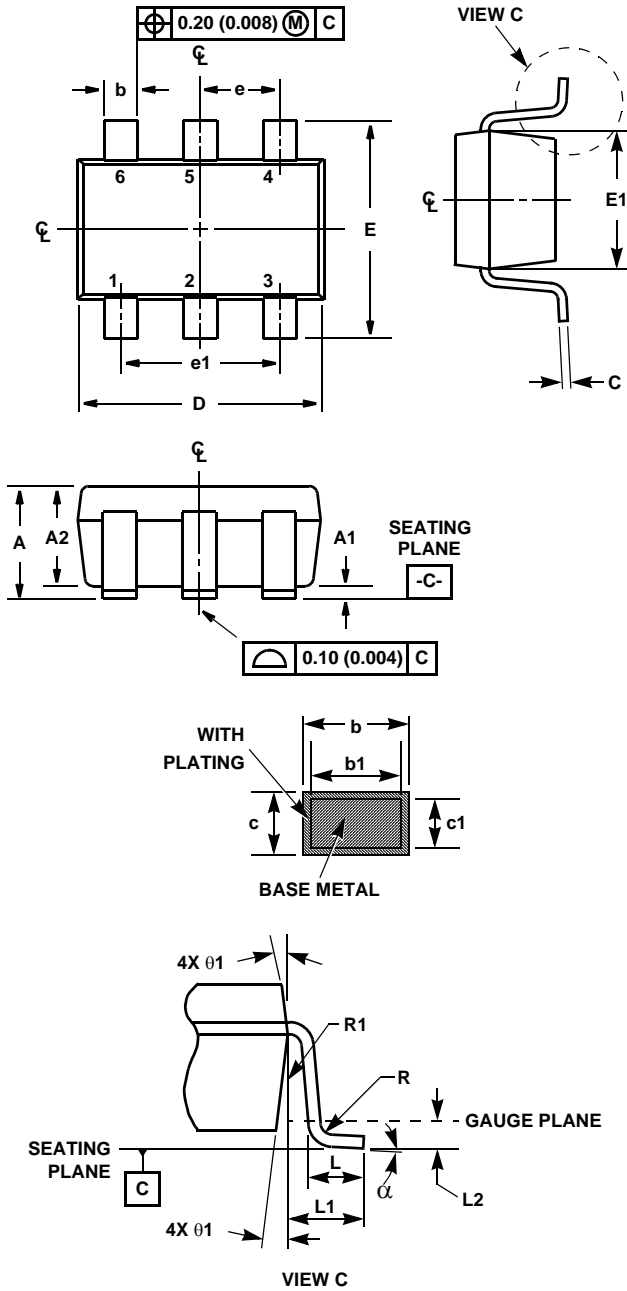

P6.064

6 LEAD SMALL OUTLINE TRANSISTOR PLASTIC PACKAGE

SYMBOL	INCHES		MILLIMETERS		NOTES
	MIN	MAX	MIN	MAX	
A	0.036	0.057	0.90	1.45	-
A1	0.000	0.0059	0.00	0.15	-
A2	0.036	0.051	0.90	1.30	-
b	0.012	0.020	0.30	0.50	-
b1	0.012	0.018	0.30	0.45	-
c	0.003	0.009	0.08	0.22	6
c1	0.003	0.008	0.08	0.20	6
D	0.111	0.118	2.80	3.00	3
E	0.103	0.118	2.60	3.00	-
E1	0.060	0.068	1.50	1.75	3
e	0.0374 Ref		0.95 Ref		-
e1	0.0748 Ref		1.90 Ref		-
L	0.014	0.022	0.35	0.55	4
L1	0.024 Ref.		0.60 Ref.		-
L2	0.010 Ref.		0.25 Ref.		-
N	6		6		5
R	0.004	-	0.10	-	-
R1	0.004	0.010	0.10	0.25	-
α	0°	8°	0°	8°	-

Rev. 3 9/03

NOTES:

1. Dimensioning and tolerance per ASME Y14.5M-1994.
2. Package conforms to EIAJ SC-74 and JEDEC MO178AB.
3. Dimensions D and E1 are exclusive of mold flash, protrusions, or gate burrs.
4. Footlength L measured at reference to gauge plane.
5. "N" is the number of terminal positions.
6. These Dimensions apply to the flat section of the lead between 0.08mm and 0.15mm from the lead tip.
7. Controlling dimension: MILLIMETER. Converted inch dimensions are for reference only

Small Outline Transistor Plastic Packages (SOT23-8)

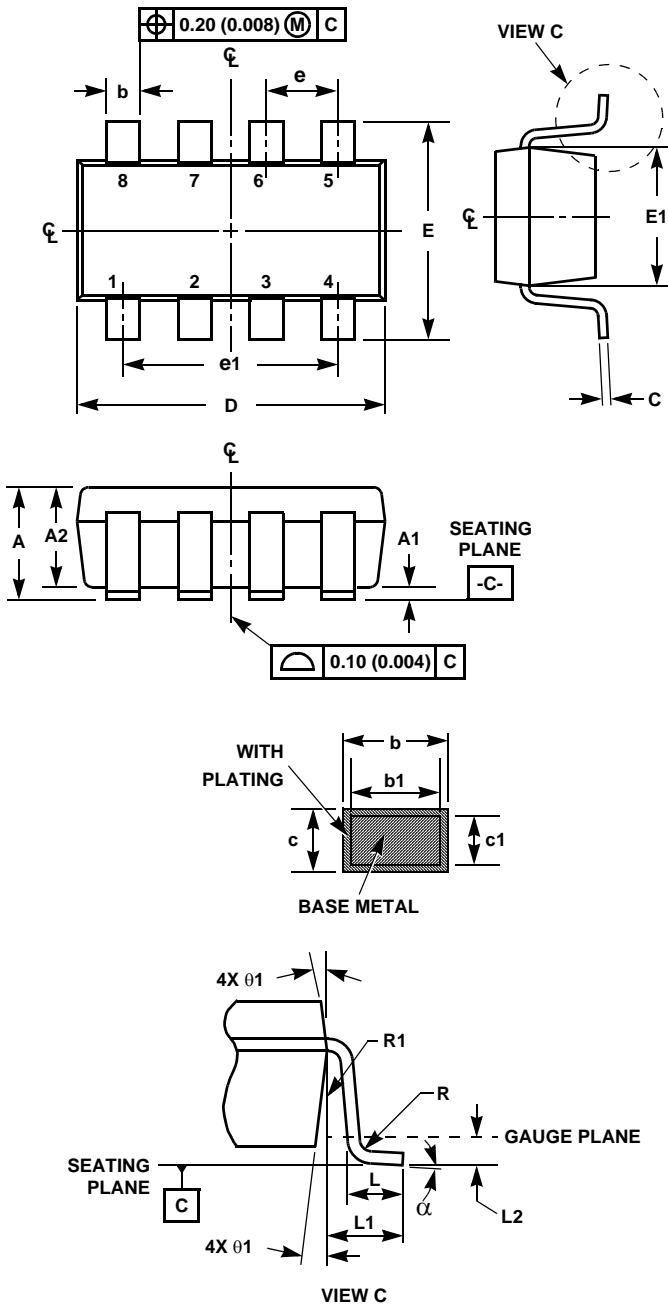

P8.064

8 LEAD SMALL OUTLINE TRANSISTOR PLASTIC PACKAGE

SYMBOL	INCHES		MILLIMETERS		NOTES
	MIN	MAX	MIN	MAX	
A	0.036	0.057	0.90	1.45	-
A1	0.000	0.0059	0.00	0.15	-
A2	0.036	0.051	0.90	1.30	-
b	0.009	0.015	0.22	0.38	-
b1	0.009	0.013	0.22	0.33	-
c	0.003	0.009	0.08	0.22	6
c1	0.003	0.008	0.08	0.20	6
D	0.111	0.118	2.80	3.00	3
E	0.103	0.118	2.60	3.00	-
E1	0.060	0.067	1.50	1.70	3
e	0.0256 Ref		0.65 Ref		-
e1	0.0768 Ref		1.95 Ref		-
L	0.014	0.022	0.35	0.55	4
L1	0.024 Ref.		0.60 Ref.		-
L2	0.010 Ref.		0.25 Ref.		-
N	8		8		5
R	0.004	-	0.10	-	-
R1	0.004	0.010	0.10	0.25	-
α	0°	8°	0°	8°	-

Rev. 2 9/03

NOTES:

1. Dimensioning and tolerance per ASME Y14.5M-1994.
2. Package conforms to EIAJ SC-74 and JEDEC MO178BA.
3. Dimensions D and E1 are exclusive of mold flash, protrusions, or gate burrs.
4. Footlength L measured at reference to gauge plane.
5. "N" is the number of terminal positions.
6. These Dimensions apply to the flat section of the lead between 0.08mm and 0.15mm from the lead tip.
7. Controlling dimension: MILLIMETER. Converted inch dimensions are for reference only

All Intersil U.S. products are manufactured, assembled and tested utilizing ISO9000 quality systems.

Intersil Corporation's quality certifications can be viewed at www.intersil.com/design/quality

Intersil products are sold by description only. Intersil Corporation reserves the right to make changes in circuit design, software and/or specifications at any time without notice. Accordingly, the reader is cautioned to verify that data sheets are current before placing orders. Information furnished by Intersil is believed to be accurate and reliable. However, no responsibility is assumed by Intersil or its subsidiaries for its use; nor for any infringements of patents or other rights of third parties which may result from its use. No license is granted by implication or otherwise under any patent or patent rights of Intersil or its subsidiaries.

For information regarding Intersil Corporation and its products, see www.intersil.com