

# Multi-Phase PWM Controller for CPU Core Power Supply

## General Description

The RT8856 is a single/dual phase PWM controller with two integrated MOSFET drivers. Moreover, it is compliant with Intel IMVP6.5 Voltage Regulator Specification to fulfill its mobile CPU Vcore power supply requirements. The RT8856 adopts NAVP™ (Native AVP) which is Richtek's proprietary topology derived from finite DC gain compensator peak current mode, making it an easy setting PWM controller that meets all Intel AVP (Active Voltage Positioning) mobile CPU requirements.

The output voltage of the RT8856 is set by 7-bit VID code. The built-in high accuracy DAC converts the VID code ranging from 0V to 1.5V with 12.5mV per step. The system accuracy of the controller can reach 1.5%. The part supports VID on-the-fly and mode change on-the-fly functions that are fully compliant with IMVP6.5 specification. It operates in single phase, dual phase and RFM. It can reach up to 90% efficiency in different modes according to different loading conditions. The droop load line can be easily programmed by setting the DC gain of the error amplifier. With proper compensation, the load transient can achieve optimized AVP performance. This chip controls soft-start and output transition slew rate via a capacitor. It supports both DCR and sense resistor current sensing. The current mode NAVP™ topology with high accuracy current sensing amplifier well balances the RT8856's channel currents.

The RT8856 provides power good, clock enabling and thermal throttling output signals for IMVP6.5 specification. It also features complete fault protection functions including over voltage, under voltage, negative voltage, over current, thermal shutdown, and under voltage lockout.

The RT8856 is available in a WQFN-40L 6x6 small foot print package.

## Applications

- IMVP6.5 Core Supply
- Multi-phase CPU Core Supply
- AVP Step-Down Converter
- Notebook/Desktop Computer/ Servers

## Features

- 1/2 Phase PWM Controller with 2 Integrated MOSFET Drivers
- IMVP6.5 Compatible Power Management States (DPSRLVR,  $\overline{PSI}$ , Extended Deeper Sleep Mode)
- NAVP (Native AVP) Topology
- 7-bit DAC
- 0.8% DAC Accuracy
- Fixed  $V_{BOOT}$  (1.1V)
- Differential Remote Voltage Sensing
- Programmable Output Transition Slew Rate Control
- Accurate Current and Thermal Balance
- System Thermal Compensation AVP
- Ringing Free Mode at Light Load Conditions
- Fast Transient Response
- Power Good
- Clock Enable Output
- Thermal Throttling
- Current Monitor Output
- Switching Frequency up to 1MHz Per Phase
- OVP, UVP, NVP, OCP, OTP, UVLO
- 40-Lead WQFN Package
- RoHS Compliant and Halogen Free

## Ordering Information

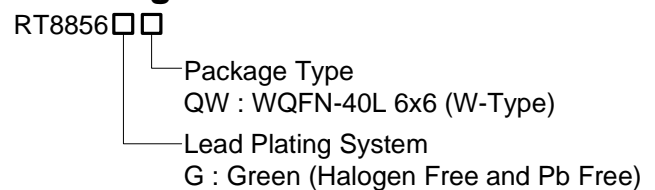

Note :

Richtek products are :

- ▶ RoHS compliant and compatible with the current requirements of IPC/JEDEC J-STD-020.
- ▶ Suitable for use in SnPb or Pb-free soldering processes.

## Marking Information

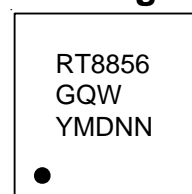

RT8856GQW : Product Number  
YMDNN : Date Code



**Table 1. IMVP6.5 VID code table**

VID6	VID5	VID4	VID3	VID2	VID1	VID0	Output
0	0	0	0	0	0	0	1.5000V
0	0	0	0	0	0	1	1.4875V
0	0	0	0	0	1	0	1.4750V
0	0	0	0	0	1	1	1.4625V
0	0	0	0	1	0	0	1.4500V
0	0	0	0	1	0	1	1.4375V
0	0	0	0	1	1	0	1.4250V
0	0	0	0	1	1	1	1.4125V
0	0	0	1	0	0	0	1.4000V
0	0	0	1	0	0	1	1.3875V
0	0	0	1	0	1	0	1.3750V
0	0	0	1	0	1	1	1.3625V
0	0	0	1	1	0	0	1.3500V
0	0	0	1	1	0	1	1.3375V
0	0	0	1	1	1	0	1.3250V
0	0	0	1	1	1	1	1.3125V
0	0	1	0	0	0	0	1.3000V
0	0	1	0	0	0	1	1.2875V
0	0	1	0	0	1	0	1.2750V
0	0	1	0	0	1	1	1.2625V
0	0	1	0	1	0	0	1.2500V
0	0	1	0	1	0	1	1.2375V
0	0	1	0	1	1	0	1.2250V
0	0	1	0	1	1	1	1.2125V
0	0	1	1	0	0	0	1.2000V
0	0	1	1	0	0	1	1.1875V
0	0	1	1	0	1	0	1.1750V
0	0	1	1	0	1	1	1.1625V
0	0	1	1	1	0	0	1.1500V
0	0	1	1	1	0	1	1.1375V
0	0	1	1	1	1	0	1.1250V
0	0	1	1	1	1	1	1.1125V
0	1	0	0	0	0	0	1.1000V

VID6	VID5	VID4	VID3	VID2	VID1	VID0	Output
0	1	0	0	0	0	1	1.0875V
0	1	0	0	0	1	0	1.0750V
0	1	0	0	0	1	1	1.0625V
0	1	0	0	1	0	0	1.0500V
0	1	0	0	1	0	1	1.0375V
0	1	0	0	1	1	0	1.0250V
0	1	0	0	1	1	1	1.0125V
0	1	0	1	0	0	0	1.0000V
0	1	0	1	0	0	1	0.9875V
0	1	0	1	0	1	0	0.9750V
0	1	0	1	0	1	1	0.9625V
0	1	0	1	1	0	0	0.9500V
0	1	0	1	1	0	1	0.9375V
0	1	0	1	1	1	0	0.9250V
0	1	0	1	1	1	1	0.9125V
0	1	1	0	0	0	0	0.9000V
0	1	1	0	0	0	1	0.8875V
0	1	1	0	0	1	0	0.8750V
0	1	1	0	0	1	1	0.8625V
0	1	1	0	1	0	0	0.8500V
0	1	1	0	1	0	1	0.8375V
0	1	1	0	1	1	0	0.8250V
0	1	1	0	1	1	1	0.8125V
0	1	1	1	0	0	0	0.8000V
0	1	1	1	0	0	1	0.7875V
0	1	1	1	0	1	0	0.7750V
0	1	1	1	0	1	1	0.7625V
0	1	1	1	1	0	0	0.7500V
0	1	1	1	1	0	1	0.7375V
0	1	1	1	1	1	0	0.7250V
0	1	1	1	1	1	1	0.7125V
1	0	0	0	0	0	0	0.7000V
1	0	0	0	0	0	1	0.6875V

*To be continued*

VID6	VID5	VID4	VID3	VID2	VID1	VID0	Output
1	0	0	0	0	1	0	0.6750V
1	0	0	0	0	1	1	0.6625V
1	0	0	0	1	0	0	0.6500V
1	0	0	0	1	0	1	0.6375V
1	0	0	0	1	1	0	0.6250V
1	0	0	0	1	1	1	0.6125V
1	0	0	1	0	0	0	0.6000V
1	0	0	1	0	0	1	0.5875V
1	0	0	1	0	1	0	0.5750V
1	0	0	1	0	1	1	0.5625V
1	0	0	1	1	0	0	0.5500V
1	0	0	1	1	0	1	0.5375V
1	0	0	1	1	1	0	0.5250V
1	0	0	1	1	1	1	0.5125V
1	0	1	0	0	0	0	0.5000V
1	0	1	0	0	0	1	0.4875V
1	0	1	0	0	1	0	0.4750V
1	0	1	0	0	1	1	0.4625V
1	0	1	0	1	0	0	0.4500V
1	0	1	0	1	0	1	0.4375V
1	0	1	0	1	1	0	0.4250V
1	0	1	0	1	1	1	0.4125V
1	0	1	1	0	0	0	0.4000V
1	0	1	1	0	0	1	0.3875V
1	0	1	1	0	1	0	0.3750V
1	0	1	1	0	1	1	0.3625V
1	0	1	1	1	0	0	0.3500V
1	0	1	1	1	0	1	0.3375V
1	0	1	1	1	1	0	0.3250V
1	0	1	1	1	1	1	0.3125V
1	1	0	0	0	0	0	0.3000V

VID6	VID5	VID4	VID3	VID2	VID1	VID0	Output
1	1	0	0	0	0	1	0.2875V
1	1	0	0	0	1	0	0.2750V
1	1	0	0	0	1	1	0.2625V
1	1	0	0	1	0	0	0.2500V
1	1	0	0	1	0	1	0.2375V
1	1	0	0	1	1	0	0.2250V
1	1	0	0	1	1	1	0.2125V
1	1	0	1	0	0	0	0.2000V
1	1	0	1	0	0	1	0.1875V
1	1	0	1	0	1	0	0.1750V
1	1	0	1	0	1	1	0.1625V
1	1	0	1	1	0	0	0.1500V
1	1	0	1	1	0	1	0.1375V
1	1	0	1	1	1	0	0.1250V
1	1	0	1	1	1	1	0.1125V
1	1	1	0	0	0	0	0.1000V
1	1	1	0	0	0	1	0.0875V
1	1	1	0	0	1	0	0.0750V
1	1	1	0	0	1	1	0.0625V
1	1	1	0	1	0	0	0.0500V
1	1	1	0	1	0	1	0.0375V
1	1	1	0	1	1	0	0.0250V
1	1	1	0	1	1	1	0.0125V
1	1	1	1	0	0	0	0.0000V
1	1	1	1	0	0	1	0.0000V
1	1	1	1	0	1	0	0.0000V
1	1	1	1	0	1	1	0.0000V
1	1	1	1	1	0	0	0.0000V
1	1	1	1	1	0	1	0.0000V
1	1	1	1	1	1	0	0.0000V
1	1	1	1	1	1	1	0.0000V

**Functional Pin Description**

Pin No.	Pin Name	Pin Function
1	DPRSLPVR	Deeper Sleep Mode Signal. Together with $\overline{\text{PSI}}$ , the combination of these two pins indicates the power management states.
2	VRON	Voltage Regulator Enabler.
3	FS	Frequency Setting. Connect this pin with a resistor to ground to set the operating frequency.
4	CM	Current Monitor Output. This pin outputs a voltage proportional to the output current.
5	CMSET	Current Monitor Output Gain Externally Setting. Connect this pin with one resistor to VSEN while CM pin is connected to ground with another resistor. The current monitor output gain can be set by the ratio of these two resistors.
6 to 12	VID[6:0]	Voltage ID. DAC voltage identification inputs for IMVP6.5. The logic threshold is 30% of VCCP as the maximum value for low state and 70% of VCCP as the minimum value for the high state. VCCP is 1.05V.
13	$\overline{\text{PSI}}$	Power Status Indicator II. Together with DPRSLPVR, the combination of these two pins indicates the power management states.
14	COMP	Compensation. This pin is the output node of the error amplifier.
15	FB	Feedback. This is the negative input node of the error amplifier.
16	VSEN	Positive Voltage Sensing Pin. This pin is the positive node of the differential voltage sensing.
17	RGND	Return Ground. This pin is the negative node of the differential remote voltage sensing.
18	SOFT	Soft-Start. This pin provides soft-start function and slew rate control. The capacitance of the slew rate control capacitor is restricted to be larger than 10nF. The feedback voltage of the converter follows the ramping voltage on the SOFT pin during soft-start and other voltage transitions according to different modes of operation and VID change.
19	ISEN1	Positive Input of Phase1 Current Sense.
20	ISEN1_N	Negative Input of Phase1 Current Sense.
21	BOOT1	Bootstrap Power Pin of Phase1. This pin powers the high side MOSFET drivers. Connect this pin to the junction of the bootstrap capacitor with the cathode of the bootstrap diode. Connect the anode of the bootstrap diode to the PVCC pin.
22	UGATE1	Upper Gate Drive of Phase1. This pin drives the gate of the high side MOSFETs.
23	PHASE1	Return Node of Phase1 High Side Driver. Connect this pin to high side MOSFET sources together with the low side MOSFET drains and the inductor.
24	PGND1	Driver Ground of Phase1.
25	LGATE1	Lower Gate Drive of Phase1. This pin drives the gate of the low side MOSFETs.
26	PVCC	Driver Power.
27	LGATE2	Lower Gate Drive of Phase2. This pin drives the gate of the low side MOSFETs.
28	PGND2	Driver Ground of Phase2.
29	PHASE2	Return Node of Phase2 High Side Driver. Connect this pin to high side MOSFET sources together with the low side MOSFET drains and the inductor.

*To be continued*

Pin No.	Pin Name	Pin Function
30	UGATE2	Upper Gate Drive of Phase2. This pin drives the gate of the high side MOSFETs.
31	BOOT2	Bootstrap Power Pin of Phase2. This pin powers the high side MOSFET drivers. Connect this pin to the junction of the bootstrap capacitor with the cathode of the bootstrap diode. Connect the anode of the bootstrap diode to the PVCC pin.
32	ISEN2_N	Negative Input of Phase2 Current Sense.
33	ISEN2	Positive input of Phase2 Current Sense.
34	OCSET	Over Current Protection Setting. Connect a resistive voltage divider from VCC to ground and connect the joint of the voltage divider to the OCSET pin. The voltage, $V_{OCSET}$ , determines the over current threshold, $I_{LIM}$ .
35	NTC	Thermal Detection Input for $\overline{VRTT}$ Circuit. Connect this pin with a resistive voltage divider from VCC using NTC on the top to set the thermal management threshold level.
36	$\overline{VRTT}$	Voltage Regulator Thermal Throttling. This open-drain output pin indicates the temperature exceeding the preset level when it is pulled low.
37	TON	Connect this pin to VIN with one resistor. This resistor value sets the ripple size in ringing free mode.
38	VCC	Chip Power.
39	$\overline{CLKEN}$	Inverted Clock Enable. This open-drain pin is an output indicating the start of the PLL locking of the clock chip.
40	PGOOD	Power Good Indicator.
41 (Exposed Pad)	GND	Ground. The exposed pad must be soldered to a large PCB and connected to GND for maximum power dissipation.

Function Block Diagram

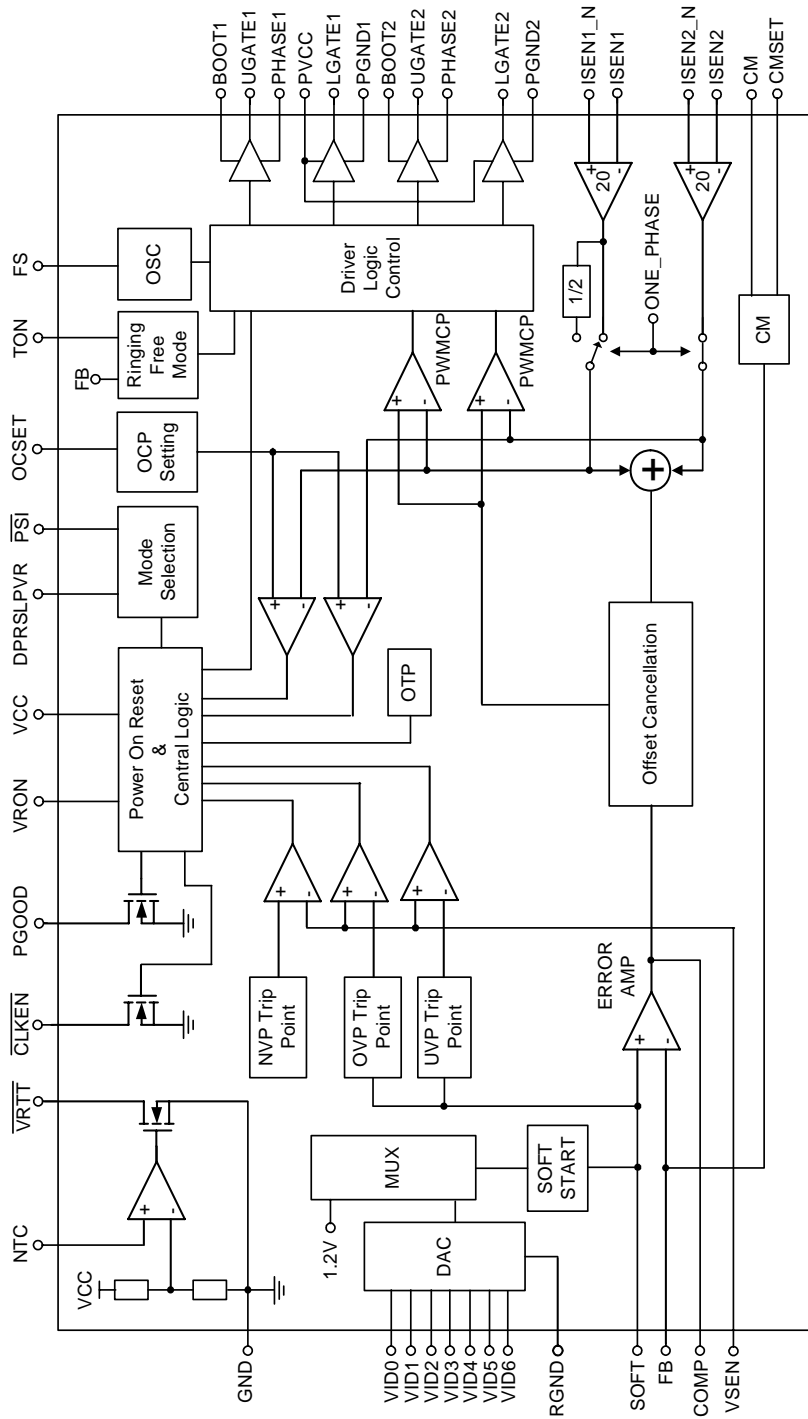

**Absolute Maximum Ratings** (Note 1)

- VCC to GND ----- -0.3V to 6.5V
- RGND, PGNDx to GND ----- -0.3V to 0.3V
- VIDx to GND ----- -0.3V to (V<sub>CC</sub> + 0.3V)
- $\overline{\text{PSI}}$ , V<sub>RON</sub> to GND ----- -0.3V to (V<sub>CC</sub> + 0.3V)
- PGOOD,  $\overline{\text{CLKEN}}$ ,  $\overline{\text{VRTT}}$  to GND ----- -0.3V to (V<sub>CC</sub> + 0.3V)
- VSEN, FB, COMP, SOFT, FS, OCSET, CM, CMSET, NTC to GND ----- -0.3V to (V<sub>CC</sub> + 0.3V)
- ISENx, ISEN1\_N, ISEN2\_N to GND ----- -0.3V to (V<sub>CC</sub> + 0.3V)
- PVCC to PGNDx ----- -0.3V to 6.5V
- LGATEx to PGNDx ----- -0.3V to (PVCC + 0.3V)
- PHASEx to PGNDx ----- -3V to 28V
- BOOTx to PHASEx ----- -0.3V to 6.5V
- UGATEx to PHASEx ----- -0.3V to (BOOTx – PHASEx)
- PGOOD ----- -0.3V to (V<sub>CC</sub> + 0.3V)
- Power Dissipation, P<sub>D</sub> @ T<sub>A</sub> = 25°C
  - WQFN-40L 6x6 ----- 2.941W
- Package Thermal Resistance (Note 2)
  - WQFN-40L 6x6,  $\theta_{JA}$  ----- 34°C/W
  - WQFN-40L 6x6,  $\theta_{JC}$  ----- 6°C/W
- Junction Temperature ----- 150°C
- Lead Temperature (Soldering, 10 sec.) ----- 260°C
- Storage Temperature Range ----- -65°C to 150°C
- ESD Susceptibility (Note 3)
  - HBM (Human Body Mode) ----- 2kV
  - MM (Machine Mode) ----- 200V

**Recommended Operating Conditions** (Note 4)

- Supply Voltage, V<sub>CC</sub> ----- 4.5V to 5.5V
- Battery Voltage, V<sub>IN</sub> ----- 7V to 24V
- Junction Temperature Range ----- -40°C to 125°C
- Ambient Temperature Range ----- -40°C to 85°C

**Electrical Characteristics**

(V<sub>CC</sub> = 5V, T<sub>A</sub> = 25°C, unless otherwise specified)

Parameter	Symbol	Test Conditions	Min	Typ	Max	Unit
<b>Supply Input</b>						
Supply Current	I <sub>VCC</sub> + I <sub>PVCC</sub>	R <sub>FS</sub> = 33kΩ, V <sub>V<sub>RON</sub></sub> = 3.3V, Not Switching	--	--	10	mA
Shutdown Current	I <sub>CC</sub> + I <sub>PVCC</sub>	V <sub>V<sub>RON</sub></sub> = 0V	--	--	5	μA
<b>Soft-Start/Slew Rate Control (based on 10nF C<sub>SS</sub>)</b>						
Soft-Start / Soft-Shutdown	I <sub>SS1</sub>	V <sub>SOFT</sub> = 1.5V	16	20	24	μA
Deeper Sleep Exit/VID Change Slew Current	I <sub>SS2</sub>	V <sub>SOFT</sub> = 1.5V	80	100	120	μA

To be continued



Parameter	Symbol	Test Conditions	Min	Typ	Max	Unit	
<b>Oscillator</b>							
Frequency	Frequency	$f_{OSC}$	$R_{FS} = 33k\Omega, V_{DAC} > 1.05$	270	300	330	kHz
	Variation		$R_{FS} = 5k\Omega \text{ to } 50k\Omega$	-20	--	20	%
Frequency Range		Per phase	200	--	1000	kHz	
Maximum Duty Cycle		Per phase	--	50	--	%	
FS pin Output Voltage	$V_{FS}$	$R_{FS} = 33k\Omega, V_{DAC} > 1.05$	1	1.05	1.1	V	
<b>Reference and DAC</b>							
DC Accuracy	$V_{FB}$	$V_{DAC} = 0.7500 - 1.5000$ (No Load, Active Mode)	-0.8	0	0.8	%VID	
		$V_{DAC} = 0.5000 - 0.7500$	-7.5	0	7.5	mV	
Boot Voltage	$V_{BOOT}$		1.089	1.1	1.111	V	
<b>Error Amplifier</b>							
DC Gain		$R_L = 47k\Omega$	70	80	--	dB	
Gain-Bandwidth Product	GBW	$C_{LOAD} = 5pF$	--	10	--	MHz	
Slew Rate	SR	$C_{LOAD} = 10pF$ (Gain = -4, $R_F = 47k\Omega, V_{OUT} = 0.5V - 3V$ )	--	5	--	V/ $\mu$ s	
Output Voltage Range	$V_{COMP}$	$R_L = 47k\Omega$	0.5	--	3.6	V	
MAX Source/Sink Current	$I_{OUTEA}$	$V_{COMP} = 2V$	--	250	--	$\mu$ A	
<b>Current Sense Amplifier</b>							
Input Offset Voltage	$V_{OSCS}$		-1	--	1	mV	
Impedance at Neg. Input	$R_{ISENx\_N}$		1	--	--	M $\Omega$	
Impedance at Pos. Input	$R_{ISENx}$		1	--	--	M $\Omega$	
DC Gain	$A_I$		--	10	--	V/V	
Input Range	$V_{ISENx\_IN}$		-50	--	100	mV	
<b>RFM TON Setting</b>							
TON Pin Output Voltage	$V_{TON}$	$R_{TON} = 80k\Omega, V_{TON} = V_{DAC} = 0.75V$	-5	0	5	%	
DEM ON-Time Setting	$t_{ON}$	$I_{RTON} = 80\mu A$	--	350	--	ns	
$R_{TON}$ Current Range	$I_{RTON}$		25	--	280	$\mu$ A	
<b>Protection</b>							
Under Voltage Lockout Threshold	$V_{UVLO}$	Falling edge	4.1	4.3	4.5	V	
Under Voltage Lockout Threshold Hysteresis	$\Delta V_{UVLO}$		--	200	--	mV	
Absolute Over Voltage Protection Threshold	$V_{OVABS}$	(With respect to 1.5V, $\pm 50mV$ )	1.45	1.5	1.55	V	
Relative Over Voltage Protection Threshold	$V_{OV}$	(With respect to $V_{VID}$ , $\pm 50mV$ )	150	200	250	mV	
Under Voltage Protection Threshold	$V_{UV}$	Measured at $V_{SEN}$ with respect to unloaded output voltage (UOV) (for $0.8 < UOV < 1.5$ )	-350	-300	-250	mV	
Negative Voltage Protection Threshold	$V_{NV}$	Measured at $V_{SEN}$ with respect to GND	-100	--	--	mV	

*To be continued*

Parameter	Symbol	Test Conditions	Min	Typ	Max	Unit	
Current Limit Threshold Voltage (Average)	V <sub>ILIM</sub>	$\Sigma (V_{ISEN_x} - V_{ISEN_{x_N}}) / N$ , V <sub>OCSET</sub> = 0.625V, V <sub>ILIMIT(nom)</sub> = 25mV	23	25	27	mV	
Current Limit Threshold Voltage (per phase)	V <sub>ILIM_PH</sub>	V <sub>ILIMITPH</sub> / V <sub>ILIMIT</sub>	--	150	--	%	
Thermal Shutdown Threshold	T <sub>SD</sub>		--	160	--	°C	
Thermal Shutdown Hysteresis	ΔT <sub>SD</sub>		--	10	--	°C	
<b>Logic Inputs</b>							
VRON Input Threshold Voltage	Logic-High	V <sub>IH</sub>	With respect to 3.3V, 70%	2.31	--	--	V
	Logic-Low	V <sub>IL</sub>	With respect to 3.3V, 30%	--	--	0.99	
Leakage Current of VRON				-1	--	1	μA
DAC (VID0 – VID6), PSI and DPRSLPVR Input Threshold Voltage	Logic-High	V <sub>IH</sub>	With respect to 1.1V, 70%	0.77	--	--	V
	Logic-Low	V <sub>IL</sub>	With respect to 1.1V, 30%	--	--	0.33	
Leakage Current of DAC (VID0 – VID6), PSI and DPRSLPVR				-1	--	1	μA
<b>Power Good</b>							
PGOOD Threshold	V <sub>TH_PGOOD</sub>		--	1	--	V	
PGOOD Low Voltage	V <sub>PGOOD</sub>	I <sub>PGOOD</sub> = 4mA	--	--	0.4	V	
PGOOD Delay	t <sub>PGOOD</sub>	CLKEN Low to PGOOD High	3	--	20	ms	
<b>Clock Enable</b>							
CLKEN Low Voltage	V <sub>CLKEN</sub>	I <sub>CLKEN</sub> = 4mA	--	--	0.4	V	
<b>Thermal Throttling</b>							
Thermal Throttling Threshold	V <sub>OT</sub>	Measure at NTC with respect to V <sub>CC</sub>	--	80	--	%V <sub>DD</sub>	
Thermal Throttling Threshold Hysteresis	V <sub>OT_HY</sub>	At V <sub>CC</sub> = 5V	--	100	--	mV	
VRTT Output Voltage	V <sub>VRTT</sub>	I <sub>VRTT</sub> = 40mA	--	--	0.4	V	
<b>Current Monitor</b>							
Current Monitor Maximum Output Voltage in Operating Range		V <sub>DAC</sub> = 1V, V <sub>RCMSET</sub> = 90mV, R <sub>CM</sub> = 50kΩ, R <sub>CMSET</sub> = 10kΩ	0.855	0.9	0.945	V	
Current Monitor Maximum Output Voltage			--	--	1.15	V	
<b>Gate Driver</b>							
UGATE Driver Source	R <sub>UGATEsr</sub>	V <sub>BOOTx</sub> – V <sub>PHASEx</sub> = 5V V <sub>BOOTx</sub> – V <sub>UGATEx</sub> = 1V	--	0.7	--	Ω	
UGATE Driver Sink	R <sub>UGATEsk</sub>	V <sub>UGATE</sub> = 1V	--	0.6	--	Ω	
LGATE Driver Source	R <sub>LGATEsr</sub>	V <sub>PVCC</sub> = 5V, V <sub>PVCC</sub> – V <sub>LGATE</sub> = 1V	--	0.7	--	Ω	
LGATE Driver Sink	R <sub>LGATEsk</sub>	V <sub>LGATE</sub> = 1V	--	0.3	--	Ω	
UGATE Driver Source/Sink Current	I <sub>UGATE</sub>	V <sub>BOOT</sub> – V <sub>PHASE</sub> = 5V V <sub>UGATE</sub> = 2.5V	--	3	--	A	
LGATE Driver Source Current	I <sub>LGATEsr</sub>	V <sub>LGATE</sub> = 2.5V	--	3	--	A	

To be continued

Parameter	Symbol	Test Conditions	Min	Typ	Max	Unit
LGATE Driver Sink Current	$I_{LGATEsk}$	$V_{LGATE} = 2.5V$	--	5	--	A
Internal Boost Charging Switch On-Resistance	$R_{BOOT}$	PVCC to BOOTx	--	30	--	$\Omega$

**Note 1.** Stresses listed as the above “Absolute Maximum Ratings” may cause permanent damage to the device. These are for stress ratings. Functional operation of the device at these or any other conditions beyond those indicated in the operational sections of the specifications is not implied. Exposure to absolute maximum rating conditions for extended periods may remain possibility to affect device reliability.

**Note 2.**  $\theta_{JA}$  is measured in natural convection at  $T_A = 25^\circ C$  on a high effective thermal conductivity four-layer test board of JEDEC 51-7 thermal measurement standard. The measured case position of  $\theta_{JC}$  is on the exposed pad of the package.

**Note 3.** Devices are ESD sensitive. Handling precaution is recommended.

**Note 4.** The device is not guaranteed to function outside its operating conditions.

Typical Operating Characteristics

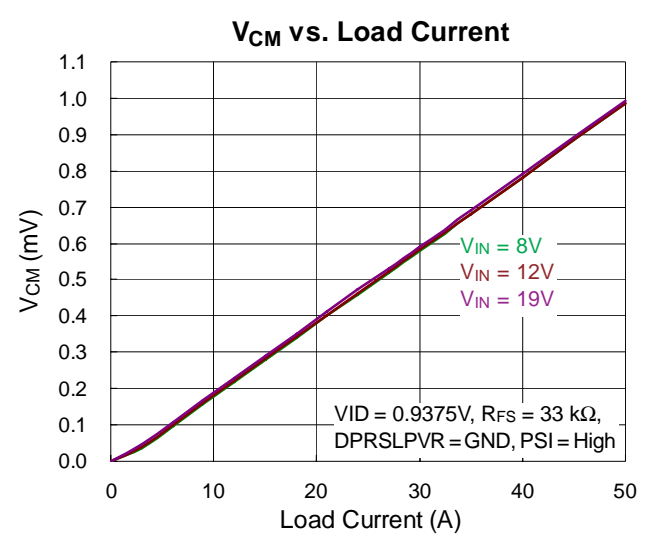
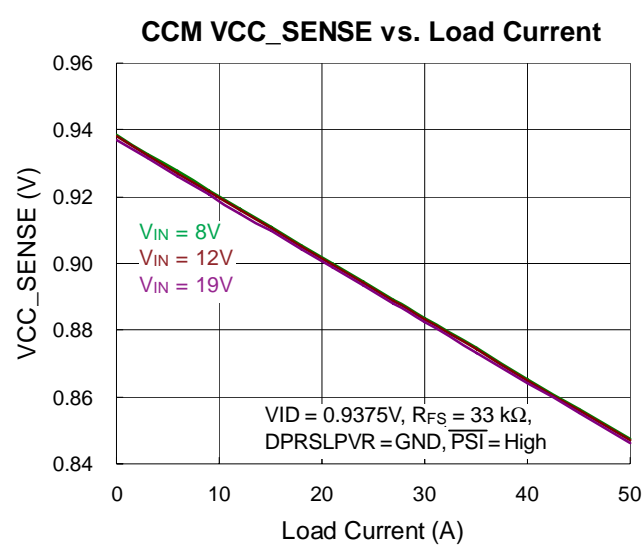
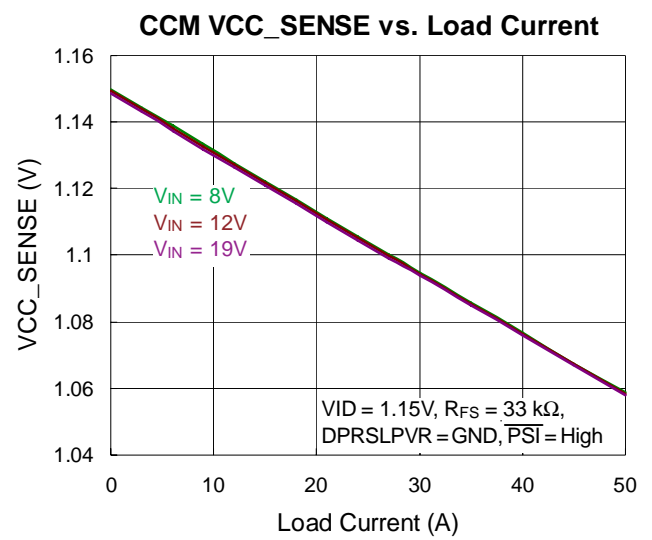
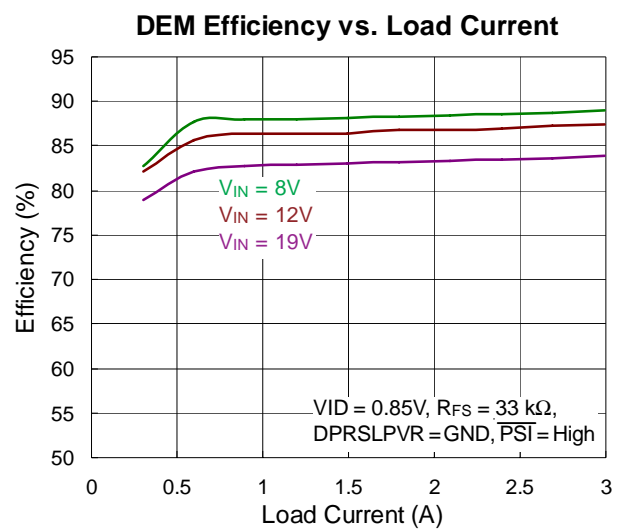
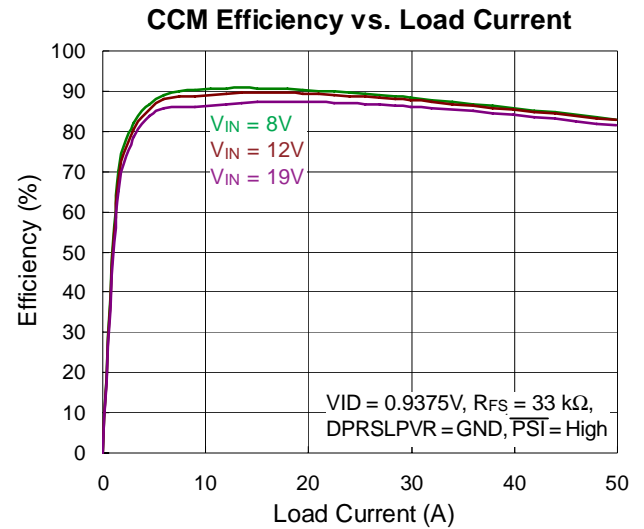
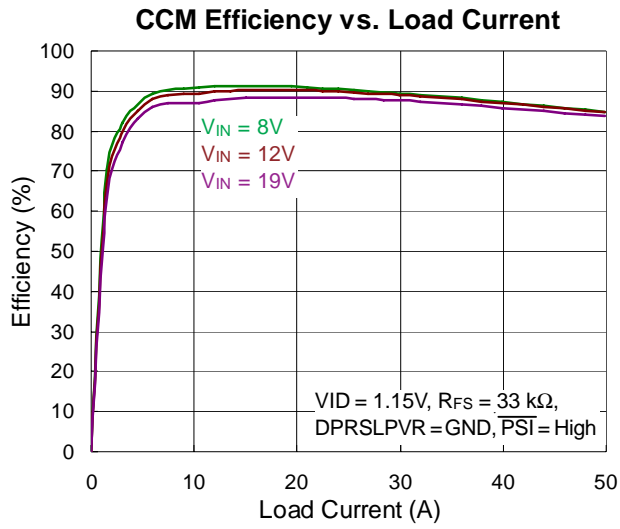

Power On from VRON

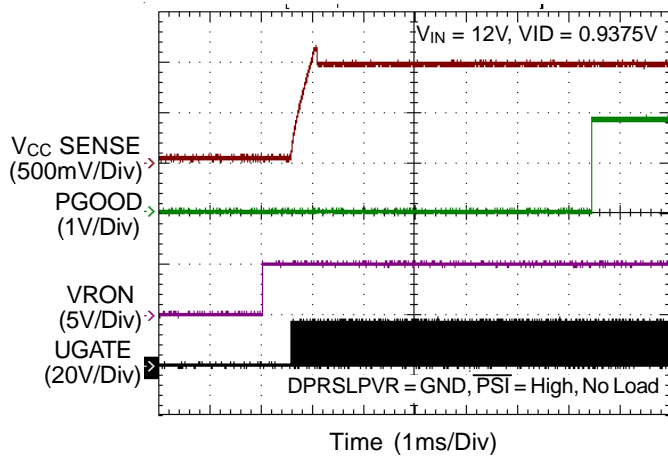

Power Off from VRON

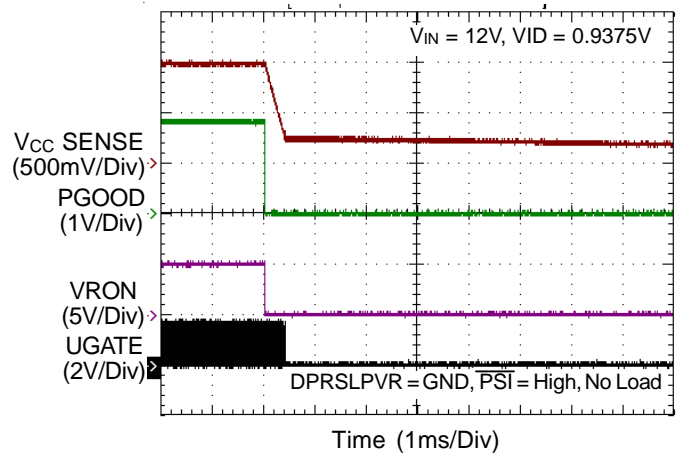

CCM VID Change Up

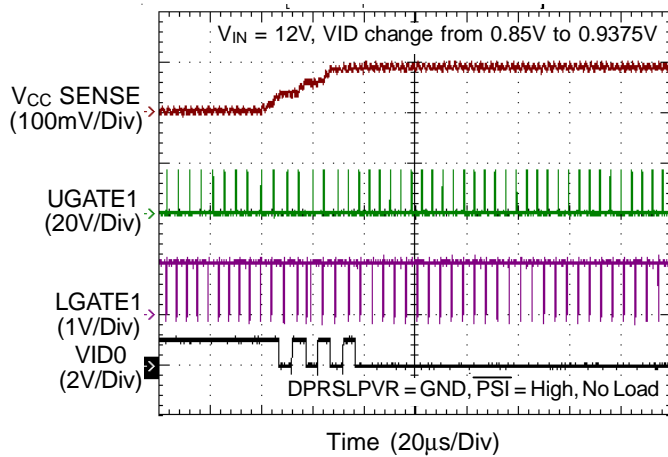

CCM VID Change Down

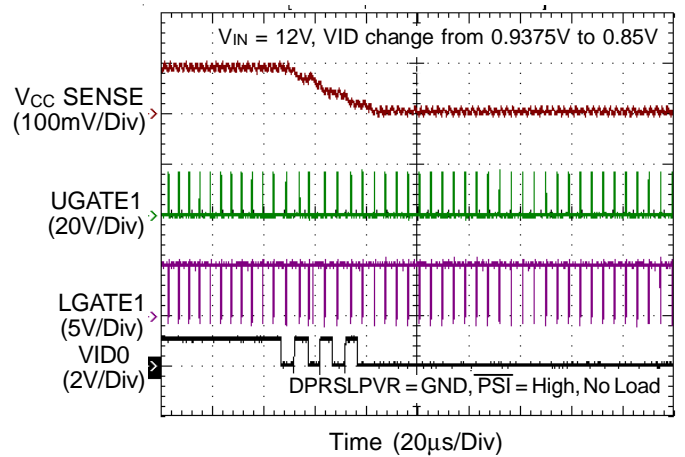

RFM VID Change Down

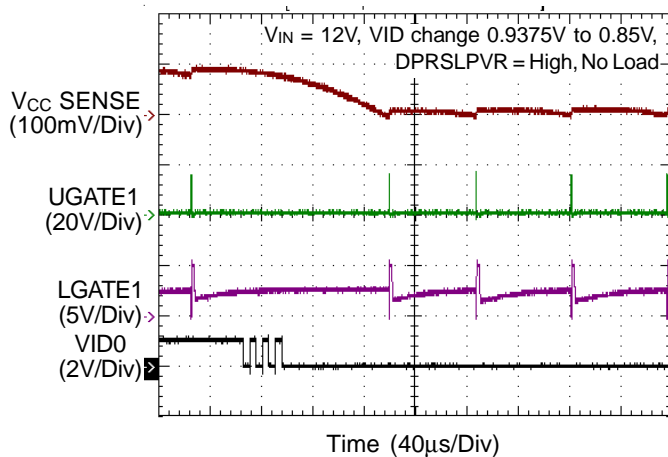

CCM Load Transient Response

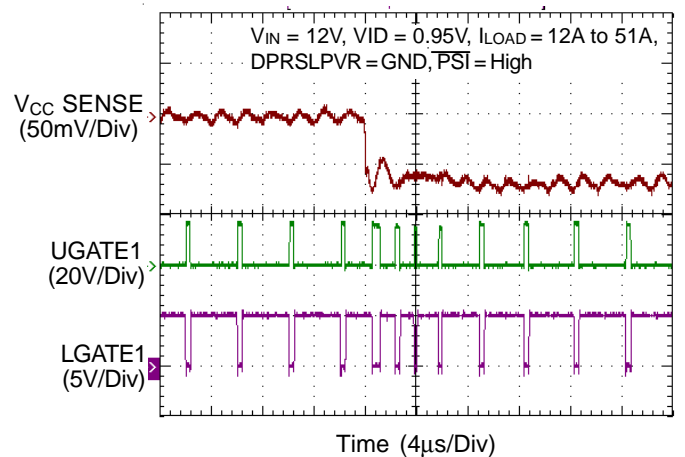

CCM Load Transient Response

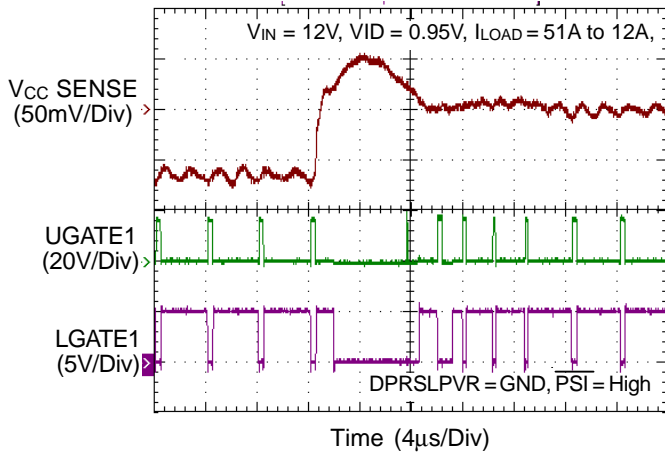

Over Current Protection

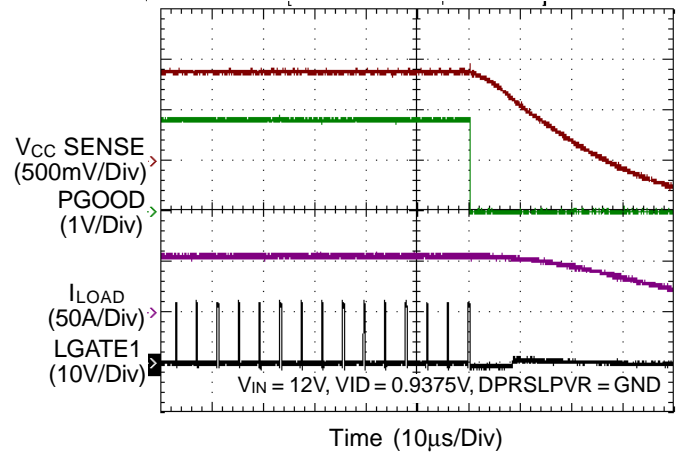

Over Voltage Protection

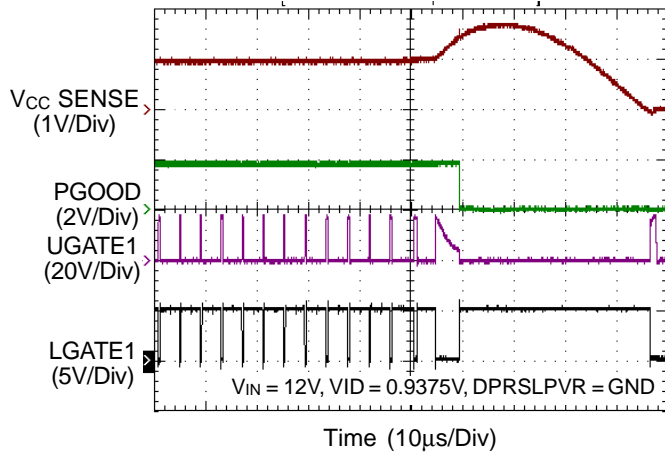

Under Voltage Protection

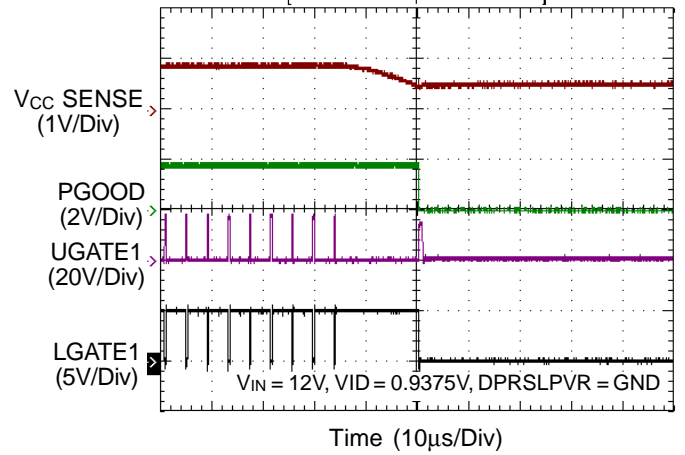

## Application Information

The RT8856 is a 1/2-phase DC/DC controller and includes embedded gate drivers for reduced system cost and board area. The number of phases is not only user selectable, but also dynamically changeable based on Intel's IMVP6.5 control signals to optimize efficiency. Phase currents are continuously sensed for loop control, droop tuning, and over current protection. The internal 7-bit VID DAC and a low offset differential amplifier allow the controller to maintain high voltage regulating accuracy to meet Intel's IMVP6.5 specification.

### Design Tool

To reduce the efforts and errors caused by manual calculations, a user friendly design tool is now available on request.

This design tool calculates all necessary design parameters by entering user's requirements. Please contact Richtek's representatives for details.

### Phase Selection and Operation Modes

The maximum number of operating phase is programmable by setting ISEN2\_N. After the initial turn-on of the RT8856, an internal comparator checks the voltage at the ISEN2\_N pin. To set the RT8856 as a pure single phase PWM controller, connect ISEN2\_N to a voltage higher than (V<sub>CC</sub> - 1V) at power on. The controller will then disable phase 2 (hold UGATE2 and LGATE2 low) and operate as a single phase PWM controller.

The RT8856 also works in conjunction with Intel's IMVP6.5 control signals, such as  $\overline{PSI}$  and DPRSLPVR. Table 2 shows the control signal truth table for operation modes of the RT8856.

For high current demand, the controller will operate with both phases active. These two phase gate signals are interleaved. This achieves minimal output voltage ripple and best transient performance.

For reduced current demand, only one phase is active. For 1-phase operation, the power stage can minimize switching losses and maintain transient response capability.

At lowest current levels, the controller enters single phase Ringing-Free Mode (RFM) to achieve highest efficiency.

**Table 2. Control signal truth table for operation modes**

DPRSLPVR	$\overline{PSI}$	Operation mode
0	1	Multi-phase CCM
0	0	Single-phase CCM
1	1	S Single-phase RFM, slow C4E
1	0	Single-phase RFM, slow C4E

### Differential Remote Sense Setting

The RT8856 includes differential, remote sense inputs to eliminate the effects of voltage drops along the PC board traces, CPU internal power routes and socket contacts. The CPU contains on-die sense pin voltages, V<sub>CC\_SENSE</sub> and V<sub>SS\_SENSE</sub>. V<sub>SS\_SENSE</sub> is connected to RGND pin. The V<sub>CC\_SENSE</sub> is connected to FB pin with a resistor to build the negative input path of the error amplifier. Connect VSEN to V<sub>CC\_SENSE</sub> for  $\overline{CLKEN}$ , PGOOD, OVP, and UVP sense. The 7-bit VIDDAC and the precision voltage reference are referred to RGND for accurate remote sensing.

### Current Sense Setting

The RT8856 continuously sense the output current of each phase. Therefore, the controller can be less noise sensitive and get more accurate current sharing between phases. Low offset amplifiers are used for loop control and current limit. The internal current sense amplifier gain (A<sub>I</sub>) is fixed to be 10. The ISEN<sub>x</sub> and ISEN<sub>x\_N</sub> denote the positive and negative input of the current sense amplifier of each phase, respectively. Users can either use a current-sense resistor or the inductor's DCR for current sensing.

Using inductor's DCR allows higher efficiency as shown in Figure 1. If

$$\frac{L}{DCR} = R_X \times C_X \tag{1}$$

then the current sense performance will be optimum. For example, choosing L = 0.36μH with 1mΩ DCR and C<sub>X</sub> = 100nF, yields R<sub>X</sub>:

$$R_X = \frac{0.36\mu H}{1.0m\Omega \times 100nF} = 3.6k\Omega \tag{2}$$

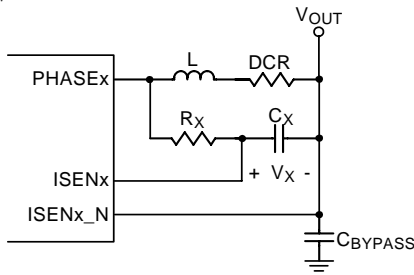

Figure 1. Lossless Inductor Sensing

Since the inductance tolerances are normally observed to be 20%, the resistor,  $R_X$ , has to be tuned on board by examining the transient voltage. If the output voltage transient has an initial dip below the minimum load line requirement with a slow recovery,  $R_X$  is chosen too small. Vice versa, with a resistance too large, the output voltage transient has only a small initial dip and the recovery is too fast, thus causing a ring-back.

Using current sense resistor in series with the inductor can have better accuracy, but the efficiency is a trade-off. Considering the equivalent inductance ( $L_{ESL}$ ) of the current sense resistor, an RC filter is recommended. The RC filter calculation method is similar to the above-mentioned inductor DCR sensing method.

**Loop Control**

The RT8856 adopts Richtek's proprietary NAVP™ topology. NAVP™ is based on the finite-gain peak current mode PWM topology. The output voltage,  $V_{OUT}$ , will decrease with increasing output load current. The control loop consists of PWM modulator with power stage, current sense amplifier and error amplifier as shown in Figure 2.

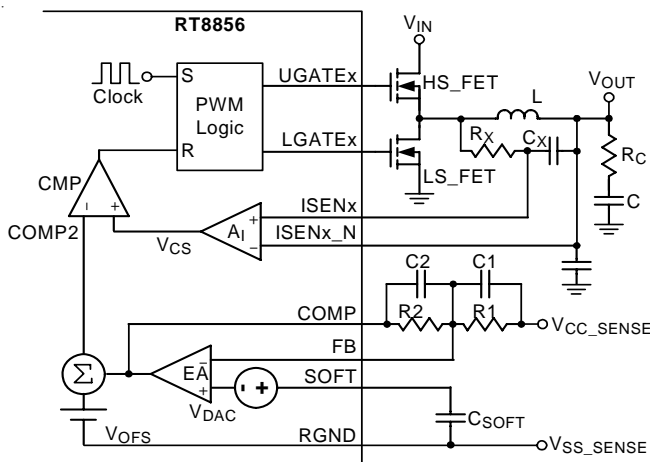

Figure 2. Simplified Schematic for Droop and Remote Sense in CCM

Similar to the peak current mode control with finite compensator gain, the HS\_FET on-time is determined by both the internal clock and the PWM comparator which compares the EA output with the output of current sense amplifier. When load current increases,  $V_{CS}$  increases, the steady state COMP voltage also increases and makes the  $V_{OUT}$  decrease, hence achieving AVP. A near-DC offset ( $V_{OFS}$ ) is added to the output EA to cancel the inherent output offset of finite-gain peak current mode controller.

In RFM, HS\_FET is turned on with constant  $T_{ON}$  when  $V_{CS}$  is lower than  $V_{COMP2}$ . Once the HS\_FET is turned off, LS\_FET is turned on automatically. By Ringing-Free Technique, the LS\_FET allows only partial of negative current when the inductor free-wheeling current reaches negative. The switching frequency will be proportionately reduced, thus the conduction and switching losses will be greatly reduced.

**Droop Setting (with Temperature Compensation)**

It's very easy to achieve Active Voltage Positioning (AVP) by properly setting the error amplifier gain with respect to the native droop characteristics. The target is to have Equation (3)

$$V_{OUT} = V_{SOFT} - I_{LOAD} \times R_{DROOP} \tag{3}$$

then solving the switching condition  $V_{COMP2} = V_{CS}$  in Figure 2 yields the desired error amplifier gain as

$$A_V = \frac{R_2}{R_1} = \frac{A_I \times R_{SENSE}}{R_{DROOP}} \tag{4}$$

where  $A_I$  is the internal current sense amplifier gain.  $R_{SENSE}$  is the current sense resistor. If there is no external sense resistor, it is the DCR of the inductor.  $R_{DROOP}$  is the resistive slope value of the converter output and is the desired static output impedance, e.g.  $-1.9m\Omega$  or  $-3m\Omega$  for IMVP6.5 specification. Increasing  $A_V$  can make load line more shallow as shown in Figure 3.

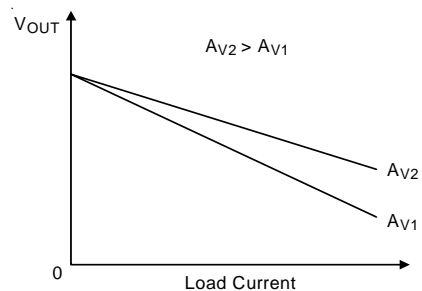

Figure 3. Error Amplifier Gain ( $A_V$ ) Influence on  $V_{OUT}$  Accuracy



Since the DCR of inductor is highly temperature dependent, it affects the output accuracy at hot conditions. Temperature compensation is recommended for the lossless inductor DCR current sense method. Figure 4 shows a simple but effective way of compensating the temperature variations of the sense resistor using an NTC thermistor placed in the feedback path.

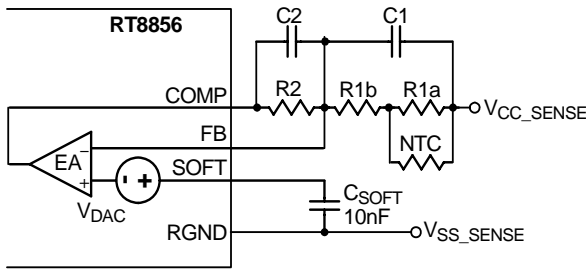

Figure 4. Loop Setting with Temperature Compensation

Usually, R1a is set to equal R<sub>NTC</sub> (25°C). R1b is selected to linearize the NTC's temperature characteristic. For a given NTC, design is to get R1b and R2 and then C1 and C2. According to Equation (4), to compensate the temperature variations of the sense resistor, the error amplifier gain (A<sub>V</sub>) should have the same temperature coefficient with R<sub>SENSE</sub>. Hence,

$$\frac{A_{V, HOT}}{A_{V, COLD}} = \frac{R_{SENSE, HOT}}{R_{SENSE, COLD}} \quad (5)$$

From Equation (4), A<sub>V</sub> can be obtained at any temperature (T) as shown below :

$$A_{V, T} = \frac{R2}{R1a // R_{NTC, T} + R1b} \quad (6)$$

The standard formula for the resistance of NTC thermistor as a function of temperature compensation is given by :

$$R_{NTC, T} = R_{25} e^{\left\{ \beta \left[ \left( \frac{1}{T+273} \right) - \left( \frac{1}{298} \right) \right] \right\}} \quad (7)$$

where R<sub>25</sub> is the thermistor's nominal resistance at room temperature, β (beta) is the thermistor's material constant in Kelvins, and T is the thermistor's actual temperature in Celsius.

To calculate DCR value at different temperature, use the equation below :

$$DCR_T = DCR_{25} \times [1 + 0.00393 \times (T - 25)] \quad (8)$$

where the 0.00393 is the temperature coefficient of the copper. For a given NTC thermistor, solving Equation (6) at room temperature (25°C) yields

$$R2 = A_{V, 25} \times (R1b + R1a // R_{NTC, 25}) \quad (9)$$

where A<sub>V, 25</sub> is the error amplifier gain at room temperature and can be obtained from Equation (4). R1b can be obtained by substituting Equation (9) to (5),

$$R1b = \frac{\frac{R_{SENSE, HOT}}{R_{SENSE, COLD}} \times (R1a // R_{NTC, HOT}) - (R1a // R_{NTC, HOT})}{\left( 1 - \frac{R_{SENSE, HOT}}{R_{SENSE, COLD}} \right)} \quad (10)$$

### Loop Compensation

Optimized compensation of the RT8856 allows for best possible load step response of the regulator's output. A type-II compensator with one pole and one zero is adequate for a proper compensation. Figure 4 shows the compensation circuit. Prior design procedure shows how to select the resistive feedback components for the error amplifier gain. Next, the C1 and C2 must be calculated for the compensation. The target is to achieve constant resistive output impedance over the widest possible frequency range.

The pole frequency of the compensator must be set to compensate the output capacitor ESR zero :

$$f_p = \frac{1}{2 \times \pi \times C \times R_C} \quad (11)$$

where C is the capacitance of output capacitor, and R<sub>C</sub> is the ESR of output capacitor. C2 can be calculated as follows :

$$C2 = \frac{C \times R_C}{R2} \quad (12)$$

The zero of compensator has to be placed at half of the switching frequency to filter the switching related noise. such that,

$$C1 = \frac{1}{(R1b + R1a // R_{NTC, 25}) \times \pi \times f_{SW}} \quad (13)$$

## Frequency Setting

High frequency operation optimizes the application for smaller component size, but trades off efficiency due to higher switching losses. This may be acceptable in ultra-portable devices where the load currents are lower and the controller is powered from a lower voltage supply. Low frequency operation offers the best overall efficiency at the expense of component size and board space.

Connect a resistor ( $R_{FS}$ ) between FS and ground to set the switching frequency ( $f_{SW}$ ) per phase :

$$R_{FS}(\text{k}\Omega) = \frac{300(\text{kHz}) \times 33(\text{k}\Omega)}{f_{SW}(\text{kHz})} \quad (14)$$

A resistor of 5k $\Omega$  to 50k $\Omega$  corresponds to switching frequency of 1MHz to 200kHz, respectively.

## Soft-Start and Mode Change Slew Rates

The RT8856 uses 2 slew rates for various modes of operation. These two slew rates are internally determined by commanding one of two bi-directional current sources on to the SOFT pin ( $I_{SS}$ ). The 7-bit VID DAC and the precision voltage reference are referred to RGND for accurate remote sensing. Hence, connect a capacitor ( $C_{SOFT}$ ) from SOFT pin to RGND for controlling the slew rate as shown in Figure 4. The capacitance of capacitor is restricted to be larger than 10nF. The voltage on SOFT pin ( $V_{SOFT}$ ) is higher than the reference voltage of the error amplifier at about 0.9V.

The first current of typically 20 $\mu\text{A}$  is used to charge or discharge the  $C_{SOFT}$  during soft-start, soft-shutdown. The second current of typically 100 $\mu\text{A}$  is used during other voltage transitions, including VID change and transitions between operation modes.

The IMVP6.5 specification specifies the critical timing associated with regulating the output voltage. The symbol, SLEWRATE, as given in the IMVP6.5 specification will determine the choice of the SOFT capacitor,  $C_{SOFT}$ , by the following equation :

$$C_{SOFT}(\text{nF}) = \frac{I_{SS}(\mu\text{A})}{\text{SLEWRATE}(\text{mV} / \mu\text{s})} \quad (15)$$

## Power Up Sequence

With the controller's VCC voltage above the POR threshold (typ. 4.3V), the power-up sequence begins when VRON exceeds the 3.3V logic high threshold. Approximately 20 $\mu\text{s}$  later, SOFT and  $V_{CORE}$  starts ramping up to boot voltage (1.1V) with maximum phases. The slew rate during power-up is 20 $\mu\text{A}/C_{SOFT}$ . The RT8856 pulls  $\overline{\text{CLKEN}}$  low after  $V_{VSEN}$  rises above 1V for 73 $\mu\text{s}$ . Right after  $\overline{\text{CLKEN}}$  goes low, SOFT and  $V_{CORE}$  starts ramping to first DAC value. After  $\overline{\text{CLKEN}}$  goes low for approximate 4.7ms, PGOOD is asserted HIGH. DPRSLPVR and  $\overline{\text{PSI}}$  are valid right after PGOOD is asserted. UVP is masked as long as  $V_{SOFT}$  is less than 1V.

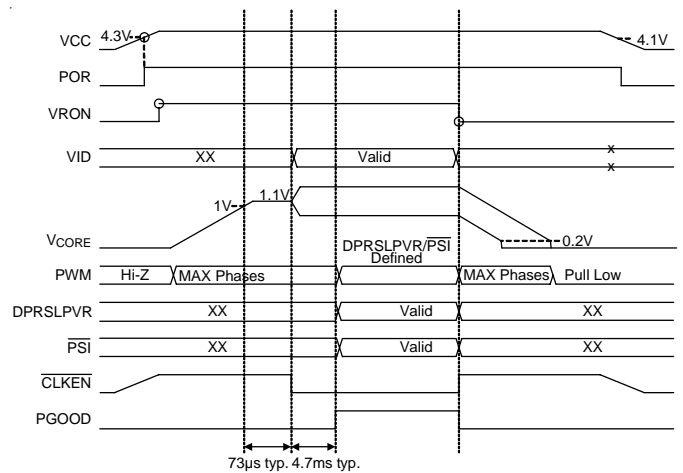

Figure 5. Timing Diagram for Power-Up and Power-Down

## Power Down

When VRON goes low, the RT8856 enters low-power shutdown mode. PGOOD is pulled low immediately and  $V_{SOFT}$  ramps down with slew rate of 20 $\mu\text{A}/C_{SOFT}$ .  $V_{VSEN}$  also ramps down following  $V_{SOFT}$  with maximum phases. After  $V_{VSEN}$  falls below 200mV, the RT8856 turns off both high side and low side MOSFETs. A discharging resistor at VSEN will be enabled and the analog part will be turned off.

## Deeper Sleep Mode Transitions

After DPRSLPVR goes high, the RT8856 immediately disables phase 2 (UGATE2 and LGATE2 forced low) and enters 1-phase deeper sleep mode operation. If the VIDs are set to a lower voltage setting, the output drops at a rate determined by the load and the output capacitance. The internal target  $V_{SOFT}$  still ramps as before, and UVP, OCP and OVP are masked for 73 $\mu\text{s}$ .

The RT8856 provides 2 slew rates for deeper sleep mode entry/ exit. For standard deeper sleep exit, the RT8856 immediately activates all enabled phases and ramps the output voltage to the DAC code provided by the processor at the slew rate of  $100\mu\text{A}/\text{C}_{\text{SOFT}}$ . The RT8856 remains in 1-phase ringing free mode and ramps the output voltage to the DAC code provided by the processor at the slew rate of  $20\mu\text{A}/\text{C}_{\text{SOFT}}$ .

**Current Limit Setting**

The RT8856 compares a programmable current limit set point to the voltage from the current sense amplifier output for Over Current Protection (OCP). The voltage applied to OCSET pin defines the desired current limit threshold,  $I_{\text{LIM}}$ :

$$V_{\text{OCSET}} = 25 \times I_{\text{LIM}} \times R_{\text{SENSE}} \tag{16}$$

Connect a resistive voltage divider from  $V_{\text{CC}}$  to GND, with the joint of the voltage divider connected to OCSET pin as shown in Figure 6. For a given  $R_{\text{OC2}}$ ,

$$R_{\text{OC1}} = R_{\text{OC2}} \times \left( \frac{V_{\text{CC}}}{V_{\text{OCSET}}} - 1 \right) \tag{17}$$

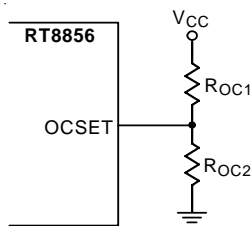

Figure 6. OCP Setting Without Temperature Compensation

The OCP works in two stages :

- ▶ Stage 1 : Average inductor current exceeds the current limit threshold,  $I_{\text{LIM}}$ , defined by  $V_{\text{OCSET}}$ , but remains smaller than 150% of  $I_{\text{LIM}}$ . If the over current condition remains valid for 16 cycles, the OCP latches and the system shuts down.
- ▶ Stage 2 : Any inductor current exceeds 150% of  $I_{\text{LIM}}$  then OCP latches instantaneously.

Latched OCP forces driver high impedance with  $\text{UGATE}_x = 0$  and  $\text{LGATE}_x = 0$ . After latched OCP happens,  $V_{\text{VSEN}}$  will be monitored. When  $V_{\text{VSEN}}$  falls below 200mV, a discharging resistor at  $V_{\text{SEN}}$  will be enabled.

If inductor DCR is used as current sense component, then

temperature compensation is recommended to protect under all conditions. Figure 7 shows a typical OCP setting with temperature compensation.

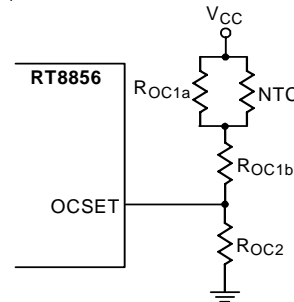

Figure 7. OCP Setting with Temperature Compensation

Usually, select  $R_{\text{OC1a}}$  equal to thermistor's nominal resistance at room temperature. Ideally,  $V_{\text{OCSET}}$  should have same temperature coefficient as  $R_{\text{SENSE}}$  (Inductor DCR) :

$$\frac{V_{\text{OCSET, HOT}}}{V_{\text{OCSET, COLD}}} = \frac{R_{\text{SENSE, HOT}}}{R_{\text{SENSE, COLD}}} \tag{18}$$

According to the basic circuit calculation,  $V_{\text{OCSET}}$  can be obtained at any temperature :

$$V_{\text{OCSET, T}} = \frac{R_{\text{OC2}}}{R_{\text{OC1a}} // R_{\text{NTC, T}} + R_{\text{OC1b}} + R_{\text{OC2}}} \tag{19}$$

Re-write Equation (18) from (19), and get  $V_{\text{OCSET}}$  at room temperature

$$\frac{R_{\text{OC1a}} // R_{\text{NTC, COLD}} + R_{\text{OC1b}} + R_{\text{OC2}}}{R_{\text{OC1a}} // R_{\text{NTC, HOT}} + R_{\text{OC1b}} + R_{\text{OC2}}} = \frac{R_{\text{SENSE, HOT}}}{R_{\text{SENSE, COLD}}} \tag{20}$$

$$V_{\text{OCSET, 25}} = \frac{R_{\text{OC2}}}{R_{\text{OC1a}} // R_{\text{NTC, 25}} + R_{\text{OC1b}} + R_{\text{OC2}}} \tag{21}$$

Solving Equation (20) and (21) yields  $R_{\text{OC1b}}$  and  $R_{\text{OC2}}$

$$R_{\text{OC2}} = \frac{\alpha \times R_{\text{EQU, HOT}} - R_{\text{EQU, COLD}} + (1 - \alpha) \times R_{\text{EQU, 25}}}{\frac{V_{\text{CC}}}{V_{\text{OCSET, 25}}} \times (1 - \alpha)} \tag{22}$$

$$R_{\text{OC1b}} = \frac{(\alpha - 1) \times R_{\text{OC2}} + \alpha \times R_{\text{EQU, HOT}} - R_{\text{EQU, COLD}}}{(1 - \alpha)} \tag{23}$$

where

$$\alpha = \frac{R_{\text{SENSE, HOT}}}{R_{\text{SENSE, COLD}}} = \frac{\text{DCR}_{25} \times [1 + 0.00393 \times (T_{\text{HOT}} - 25)]}{\text{DCR}_{25} \times [1 + 0.00393 \times (T_{\text{COLD}} - 25)]} \tag{24}$$

$$R_{EQU, T} = R_{1a} // R_{NTC, T} \quad (25)$$

For example, the following design parameters are given :

$$DCR = 1m\Omega, V_{CC} = 5V, I_{L, Ripple} = 5A$$

$$R_{OC1a} = R_{NTC, 25} = 10k\Omega, \beta_{NTC} = 2400$$

For  $-20^{\circ}C$  to  $100^{\circ}C$  operation range, to set OCP trip current  $I_{TRIP} = 57A$  when operating with maximum phases :

$$I_{LIM} = \frac{57A}{2} + 5A = 33.5A$$

$$V_{OCSET, 25} = 25 \times 33.5A \times 1m\Omega = 0.8375V$$

$$R_{NTC, -20} = 41.89k\Omega, R_{NTC, 100} = 1.98k\Omega$$

$$R_{SENSE, -20} = 0.82 m\Omega, R_{SENSE, 100} = 1.29m\Omega$$

$$\Rightarrow R_{OC2} = 2.437k\Omega, R_{OC1b} = 7.113k\Omega$$

### Over Voltage Protection (OVP)

The OVP circuit is triggered under two conditions :

- ▶ Condition 1 : When  $V_{VSEN}$  exceeds 1.55V.
- ▶ Condition 2 : When  $V_{VSEN}$  exceeds  $V_{DAC}$  by 200mV.

If either condition is valid, the RT8856 latches the  $LGATEx = 1$  and  $UGATEx = 0$  as crowbar to the output voltage of VR. Turning on all LS\_FETs can lead to very large reverse inductor current and potentially result in negative output voltage of VR. To prevent damage of the CPU by negative voltage, the RT8856 turns off all LS\_FETs when  $V_{VSEN}$  has fallen below  $-100mV$ .

### Under Voltage Protection (UVP)

If  $V_{VSEN}$  is less than  $V_{DAC}$  by 300mV or more, a UVP fault is latched and the RT8856 turns off both upper side and lower side MOSFETs.  $V_{VSEN}$  is monitored after UVP is valid. When  $V_{VSEN}$  falls below 200mV, a discharging resistor at VSEN will be enabled.

### Negative Voltage Protection (NVP)

During shutdown or protection state, when  $V_{VSEN}$  is lower than  $-100mV$ , the controller will force  $LGATEx = 0$  and  $UGATEx = 0$  for preventing negative voltage. Once  $V_{VSEN}$  recovers to be more than 0mV, NVP will be suspended and  $LGATEx = 1$  will be enabled again.

### Over Temperature Protection (OTP)

Over Temperature Protection prevents the VR from damage. OTP is considered to be the final protection stage against overheating of the VR. The thermal throttling  $VRTT$  should be set to assert prior to OTP to manage the VR power. When this measure is insufficient to keep the die temperature of the controller below the OTP threshold, OTP will be asserted and latched. The die temperature of the controller is monitored internally by a temperature sensor. As a result of OTP triggering, a soft shutdown will be launched and  $V_{VSEN}$  will be monitored. When  $V_{VSEN}$  is less than 200mV, the driver remains in high impedance state and the discharging resistor at VSEN pin will be enabled. A reset can be executed by cycling VCC or VRON.

### Thermal Throttling Control

Intel IMVP6.5 technology supports thermal throttling of the processor to prevent catastrophic thermal damage. The RT8856 includes a thermal monitoring circuit to detect an exceeded user defined temperature on a VR point. The thermal monitoring circuit senses the voltage change across the NTC pin. Figure 8 shows the principle of setting the temperature threshold. Connect an external resistive voltage divider between Vcc and GND. This divider uses a Negative Temperature Coefficient (NTC) thermistor and a resistor. The joint of the voltage divider is connected to the NTC pin in order to generate a voltage that is proportional to the temperature. The RT8856 pulls  $VRTT$  low if the voltage on the NTC pin is greater than  $0.8 \times V_{CC}$ . The internal  $VRTT$  comparator has a hysteresis of 100mV to prevent high frequency  $VRTT$  oscillation when the temperature is near the setting point. The minimum assertion/de-assertion time for  $VRTT$  toggling is 1.5ms.

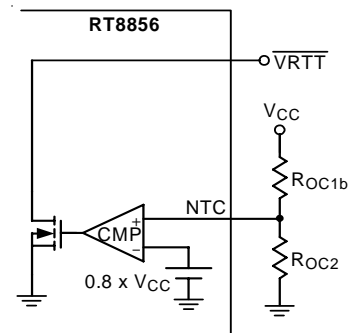

Figure 8. Thermal Throttling Setting Principle

Users can use the same NTC thermistor for both thermal throttling and current limit setting as shown in Figure 9. Just divide the  $R_{OC1b}$  into  $R_{TTa}$  and  $R_{TTb}$ , and write the  $V_{NTC}$  equation at thermal throttling temperature  $TT^{\circ}C$  :

$$R_{TTa} + R_{TTb} = R_{OC1b} \tag{26}$$

$$\frac{R_{OC2} + R_{TTb}}{R_{OC2} + R_{OC1b} + R_{OC1a} // R_{NTC, TT^{\circ}C}} \times V_{CC} = 0.8 \times V_{CC} \tag{27}$$

Solving (26) and (27) for  $R_{TTa}$  and  $R_{TTb}$  as :

$$R_{TTb} = 4 \times (R_{OC1a} // R_{NTC, TT^{\circ}C}) - R_{OC2} \tag{28}$$

$$R_{TTa} = R_{OC1b} - R_{TTb} \tag{29}$$

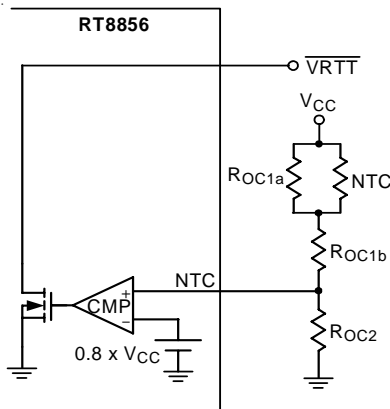

Figure 9. Using single NTC Thermistor for Thermal Throttling and Current Limit Setting

**Current Monitor**

The current monitor allows the system to accurately monitor the CPU's current dissipation and quickly predict whether the system is about to overheat before the significantly slower temperature sensor signals an over temperature alert. The voltage output of CM pin is proportional to the output current. This pin is connected to ground with one resistor while CMSET pin is connected to  $V_{VSEN}$  with another resistor. By choosing the appropriate ratio of these two resistors, current monitor gain can be set and  $V_{CM}$  will be 1V with maximum output current. Maximum value of  $V_{CM}$  is clamped at 1.15V.

$$V_{CM} = I_{LOAD} \times R_{DROOP} \times 2 \times \frac{R_{CM}}{R_{CMSET}} \tag{30}$$

**Inductor Selection**

The switching frequency and ripple current determine the inductor value as follows :

$$L_{MIN} = N \times \frac{V_{OUT(MIN)} \times (1 - D_{MIN})}{f_{SW} \times I_{Ripple}} \tag{31}$$

where N is the total number of phases.  $D_{MIN}$  is the minimum duty at highest input voltage  $V_{IN}$ .

Higher inductance yields in less ripple current and hence in higher efficiency. The flaw is the slower transient response of the power stage to load transients. This might increase the need for more output capacitors driving the cost up. Find a low loss inductor having the lowest possible DC resistance that fits in the allotted dimensions. The core must be large enough not to saturate at the peak inductor current.

**Output Capacitor Selection**

Output capacitors are used to obtain high bandwidth for the output voltage beyond the bandwidth of the converter itself. Usually, the CPU manufacturer recommends a capacitor configuration. Two different kinds of output capacitors can be found, bulk capacitors closely located to the inductors and ceramic output capacitors in close proximity to the load. The latter ones are for mid frequency decoupling with especially small ESR and ESL values while the bulk capacitors have to provide enough stored energy to overcome the low frequency bandwidth gap between the regulator and the CPU.

**Thermal Considerations**

For continuous operation, do not exceed absolute maximum junction temperature. The maximum power dissipation depends on the thermal resistance of the IC package, PCB layout, rate of surrounding airflow, and difference between junction and ambient temperature. The maximum power dissipation can be calculated by the following formula :

$$P_{D(MAX)} = (T_{J(MAX)} - T_A) / \theta_{JA}$$

where  $T_{J(MAX)}$  is the maximum junction temperature,  $T_A$  is the ambient temperature, and  $\theta_{JA}$  is the junction to ambient thermal resistance.

For recommended operating condition specifications of RT8856, the maximum junction temperature is 125°C and  $T_A$  is the ambient temperature. The junction to ambient thermal resistance,  $\theta_{JA}$ , is layout dependent. For WQFN-40L 6x6 packages, the thermal resistance,  $\theta_{JA}$ , is 34°C/W on a standard JEDEC 51-7 four-layer thermal test board. The maximum power dissipation at  $T_A = 25^\circ\text{C}$  can be calculated by the following formula :

$$P_{D(MAX)} = (125^\circ\text{C} - 25^\circ\text{C}) / (34^\circ\text{C/W}) = 2.941\text{W for WQFN-40L 6x6 package}$$

The maximum power dissipation depends on the operating ambient temperature for fixed  $T_{J(MAX)}$  and thermal resistance,  $\theta_{JA}$ . For RT8856 package, the derating curve in Figure 10 allows the designer to see the effect of rising ambient temperature on the maximum power dissipation.

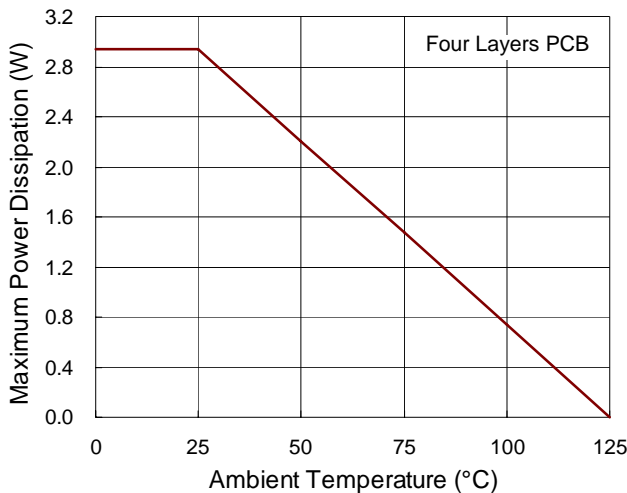

Figure 10. Derating Curves for RT8856 Packages

**Layout Considerations**

Careful PC board layout is critical to achieve low switching losses and clean, stable operation. The switching power stage requires particular attention. If possible, mount all of the power components on the top side of the board with their ground terminals flush against one another. Follow these guidelines for optimum PC board layout :

- ▶ Keep the high current paths short, especially at the ground terminals.
- ▶ Keep the power traces and load connections short. This is essential for high efficiency.
- ▶ Connect slew rate control capacitor at SOFT pin to RGND.
- ▶ When trade offs in trace lengths must be made, it's preferable to allow the inductor charging path to be made longer than the discharging path.
- ▶ Place the current sense component close to the controller. ISENx and ISENx\_N connections for current limit and voltage positioning must be made using Kelvin sense connections to guarantee the current sense accuracy. PCB trace from the sense nodes should be paralleled back to controller.
- ▶ Route high speed switching nodes away from sensitive analog areas (SOFT, COMP, FB, VSEN, ISENx, ISENx\_N, CM, CMSET, etc...)

**Outline Dimension**

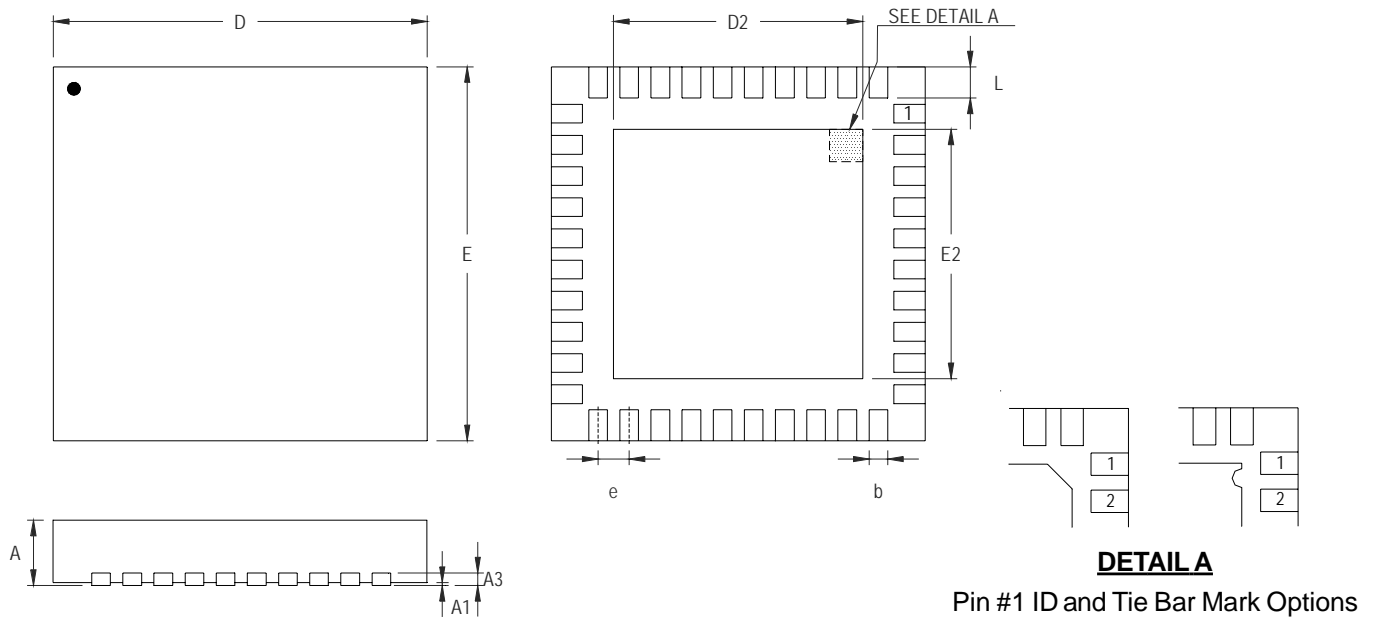

Note : The configuration of the Pin #1 identifier is optional, but must be located within the zone indicated.

Symbol	Dimensions In Millimeters		Dimensions In Inches	
	Min	Max	Min	Max
A	0.700	0.800	0.028	0.031
A1	0.000	0.050	0.000	0.002
A3	0.175	0.250	0.007	0.010
b	0.180	0.300	0.007	0.012
D	5.950	6.050	0.234	0.238
D2	4.000	4.750	0.157	0.187
E	5.950	6.050	0.234	0.238
E2	4.000	4.750	0.157	0.187
e	0.500		0.020	
L	0.350	0.450	0.014	0.018

**W-Type 40L QFN 6x6 Package**

**Richtek Technology Corporation**

Headquarter  
5F, No. 20, Taiyuen Street, Chupei City  
Hsinchu, Taiwan, R.O.C.  
Tel: (8863)5526789 Fax: (8863)5526611

**Richtek Technology Corporation**

Taipei Office (Marketing)  
5F, No. 95, Minchiuan Road, Hsintien City  
Taipei County, Taiwan, R.O.C.  
Tel: (8862)86672399 Fax: (8862)86672377  
Email: marketing@richtek.com

Information that is provided by Richtek Technology Corporation is believed to be accurate and reliable. Richtek reserves the right to make any change in circuit design, specification or other related things if necessary without notice at any time. No third party intellectual property infringement of the applications should be guaranteed by users when integrating Richtek products into any application. No legal responsibility for any said applications is assumed by Richtek.