

PLEASE CHECK WWW.MOLEX.COM FOR LATEST PART INFORMATION

Part Number: [0743371054](#)
Status: **Active**
Description: 0.80mm (.031") Pitch Ultra+™ VHDCI Receptacle, Stacked, Right Angle, Enhanced Shield, Four Press-fit Boardlocks, 136 Circuits, PC Tail Length 2.08mm (.082")

Documents:

[3D Model](#) [RoHS Certificate of Compliance \(PDF\)](#)
[Drawing \(PDF\)](#)

Agency Certification

CSA LR19980
 UL E29179

General

Product Family I/O Connectors
 Series [74337](#)
 Application Wire-to-Board
 Comments With Top Cover, Lock to Mating Part Installed on Part
 Component Type Receptacle
 Product Name SCSI+, VHDCI
 Type N/A

Physical

Boot Color N/A
 Circuits (Loaded) 136
 Circuits (maximum) 136
 Color - Resin Black
 Durability (mating cycles max) 500
 Flammability 94V-0
 Gender Female
 Lock to Mating Part Yes
 Material - Metal Brass
 Material - Plating Mating Tin
 Material - Plating Termination Tin
 Material - Resin High Temperature Thermoplastic
 Number of Rows 4
 Orientation Right Angle
 PC Tail Length (in) 0.082 In
 PC Tail Length (mm) 2.08 mm
 PCB Locator Yes
 PCB Retention Yes
 PCB Thickness Recommended (in) 0.063 In
 PCB Thickness Recommended (mm) 1.60 mm
 Packaging Type Tray
 Panel Mount Yes
 Pitch - Mating Interface (in) 0.031 In
 Pitch - Mating Interface (mm) 0.80 mm
 Pitch - Term. Interface (in) 0.031 In
 Pitch - Term. Interface (mm) 0.80 mm
 Plating min: Mating (µin) 40
 Plating min: Mating (µm) 1.00
 Plating min: Termination (µin) 40
 Plating min: Termination (µm) 1.00
 Polarized to Mating Part Yes
 Polarized to PCB Yes
 Ports 2

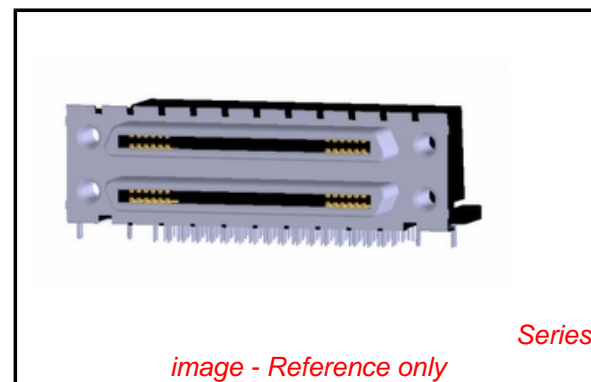

EU RoHS

RoHS Compliant by Exemption

REACH SVHC

Not Reviewed

Halogen-Free

Status

Not Reviewed

Need more information on product environmental compliance?

Email productcompliance@molex.com
 For a multiple part number RoHS Certificate of Compliance, [click here](#)

Please visit the [Contact Us](#) section for any non-product compliance questions.

China RoHS



Search Parts in this Series

[74337Series](#)

Mates With

[71425](#) Ultra+™ VHDCI Plug Kit

Surface Mount Compatible (SMC)	Yes
Temperature Range - Operating	-55°C to +85°C
Termination Interface: Style	Through Hole
Waterproof / Dustproof	No
Wire Size AWG	N/A

Electrical

Current - Maximum per Contact	0.5A
Grounding to Panel	Screw Hole
Shield Type	Full Shield
Shielded	Yes
Voltage - Maximum	30V AC (RMS)/DC

Solder Process Data

Duration at Max. Process Temperature (seconds)	40
Lead-free Process Capability	Wave Capable (TH only)
Max. Cycles at Max. Process Temperature	3
Process Temperature max. C	245

Material Info

Reference - Drawing Numbers

Sales Drawing	SD-74337-014
---------------	--------------

This document was generated on 05/28/2010

PLEASE CHECK WWW.MOLEX.COM FOR LATEST PART INFORMATION

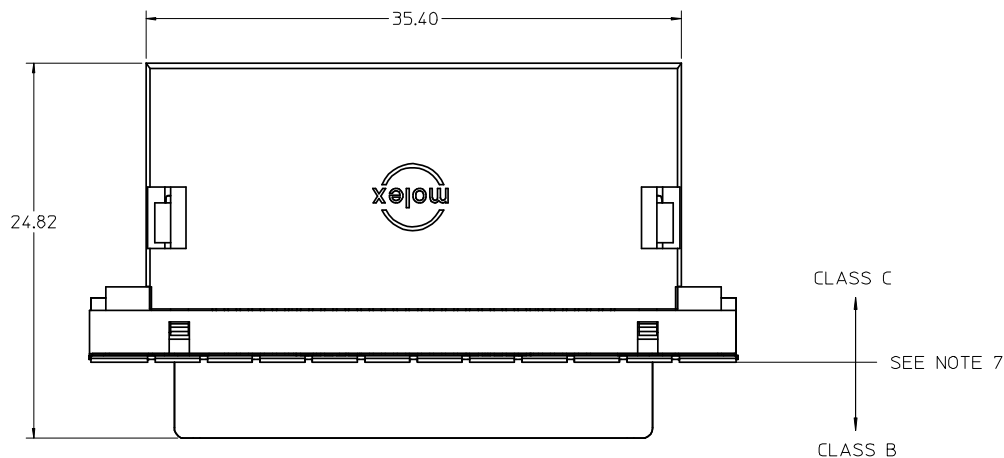

NOTES:

1. MATERIALS:
HOUSING, COVER, AND TAIL ALIGNER: HIGH TEMPERATURE THERMOPLASTIC, UL94, V-0 RATED, COLOR: BLACK
TERMINAL: PHOSPHOR BRONZE ALLOY
BRACKET: BRASS
SHELL: STEEL
INSERT: BRASS
2. FINISHES:
TERMINAL: 0.05-0.25 MICROMETERS GOLD FLASH IN CRITICAL AREA OVER 0.75 MICROMETERS MINIMUM PALLADIUM NICKEL IN CRITICAL AREA, 1.87 MICROMETERS MINIMUM TIN IN SOLDER TAIL AREA, ALL OVER NICKEL.
BRACKET: 5.0 MICROMETERS MINIMUM BRIGHT TIN.
SHIELD: 3.81 MICROMETERS MINIMUM BRIGHT TIN OVER 1.27 MICROMETERS MINIMUM NICKEL OVER COPPER FLASH (OPTIONAL).
INSERT: 2.54 MICROMETERS MINIMUM NICKEL.
3. PRODUCT SPECIFICATION: PS-71425-9999.
4. PACKAGING SPECIFICATION: TRAY PACK PER PK-74337-001.
5. APPLICABLE STANDARDS: EIA-700AAAF AND SFF-8441.
6. DATE CODE: YR/WK PER EIA-476-A.
7. PRODUCT COMPLIES WITH COSMETIC SPECIFICATION PS-45499-002. SEE FIGURE AT LEFT FOR SURFACE CLASSIFICATIONS.
8. TORQUE TO INSTALL SCREWLOCKS INTO THREADED INSERTS: 0.34 Nm MAXIMUM.

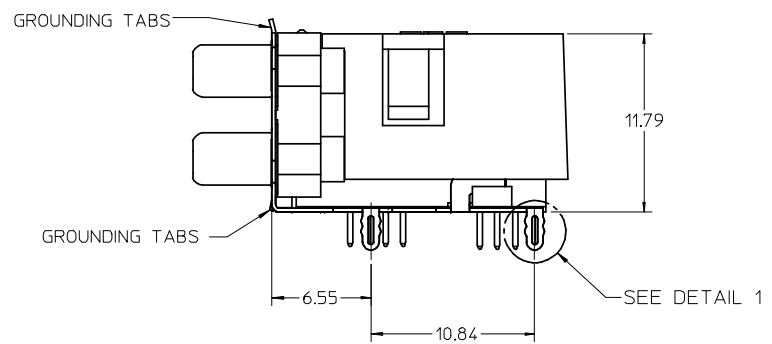
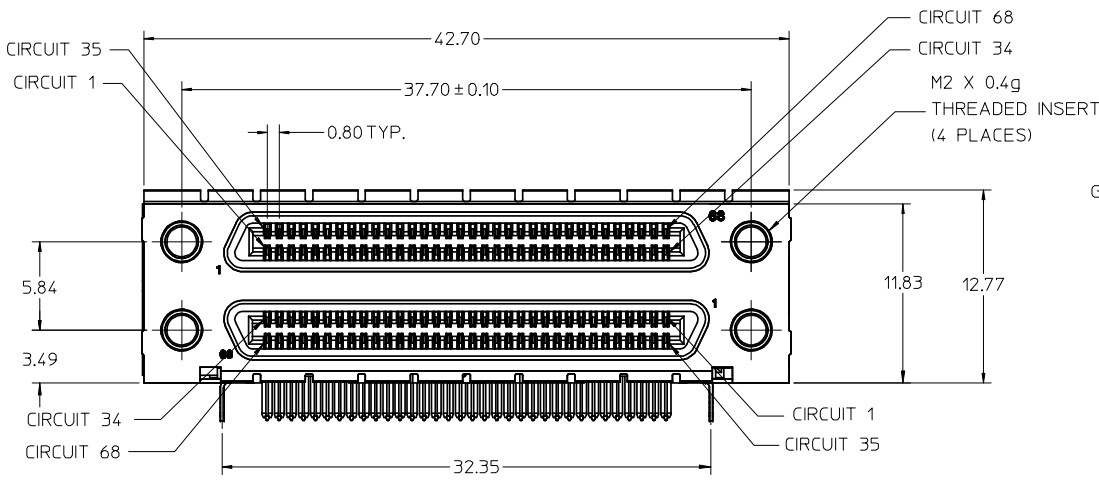

PRESS FIT FORKLOCK SHOWN (VERSION 4)

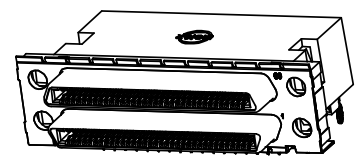

WITH COVER OPTION

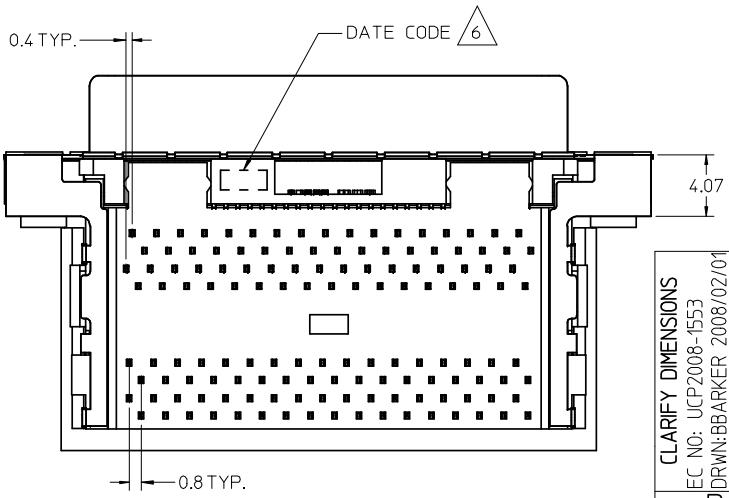

CLARIFY DIMENSIONS EC NO: UCP2008-1553 DRWN: BBARKER 2008/02/01 CHKD: DMORGAN 2008/02/07 APPR: SMILLER 2008/02/08	QUALITY SYMBOLS ▽ = 0 ▽C = 0	GENERAL TOLERANCES (UNLESS SPECIFIED) <table border="1"> <thead> <tr> <th></th> <th>mm</th> <th>INCH</th> </tr> </thead> <tbody> <tr> <td>4 PLACES</td> <td>± ---</td> <td>± ---</td> </tr> <tr> <td>3 PLACES</td> <td>± ---</td> <td>± ---</td> </tr> <tr> <td>2 PLACES</td> <td>± 0.13</td> <td>± ---</td> </tr> <tr> <td>1 PLACE</td> <td>± 0.25</td> <td>± ---</td> </tr> </tbody> </table>		mm	INCH	4 PLACES	± ---	± ---	3 PLACES	± ---	± ---	2 PLACES	± 0.13	± ---	1 PLACE	± 0.25	± ---	SCALE 3:1 DESIGN UNITS METRIC DIMENSION STYLE MM ONLY	THIRD ANGLE PROJECTION REVISIONS REV 1 DATE 05.08.2001 BY SSAMPSON	TITLE VHCI STACKED ASSEMBLY
		mm	INCH																	
	4 PLACES	± ---	± ---																	
	3 PLACES	± ---	± ---																	
2 PLACES	± 0.13	± ---																		
1 PLACE	± 0.25	± ---																		
DRAFT WHERE APPLICABLE MUST REMAIN WITHIN DIMENSIONS	APPROVED BY MBANAKIS DATE 05.08.2001	CHECKED BY MBANAKIS DATE 05.08.2001	MOLEX INCORPORATED	MATERIAL NO. SEE TABLE DOCUMENT NO. SD-74337-014 SHEET NO. 1 OF 4	THIS DRAWING CONTAINS INFORMATION THAT IS PROPRIETARY TO MOLEX INCORPORATED AND SHOULD NOT BE USED WITHOUT WRITTEN PERMISSION															

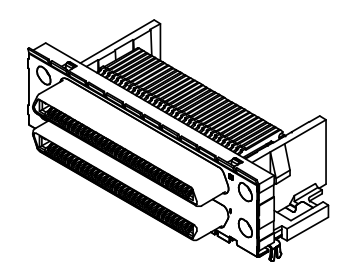
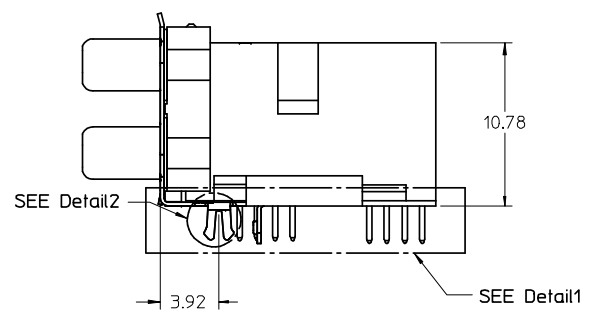
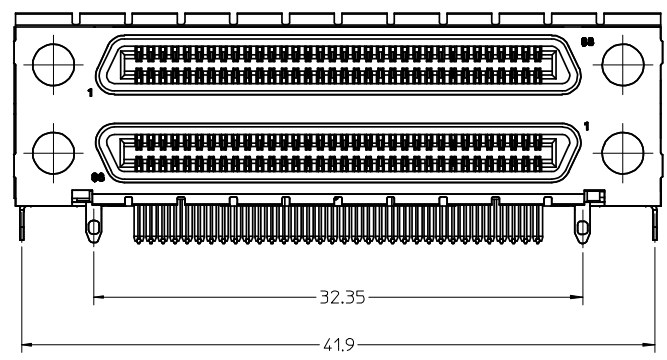
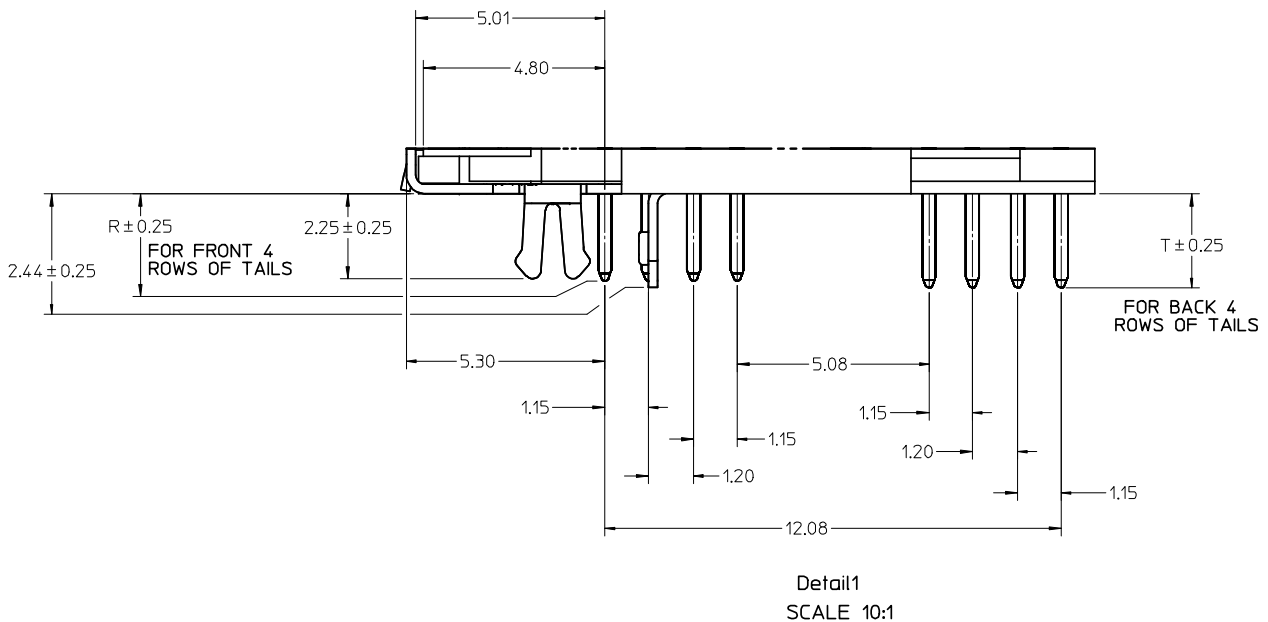
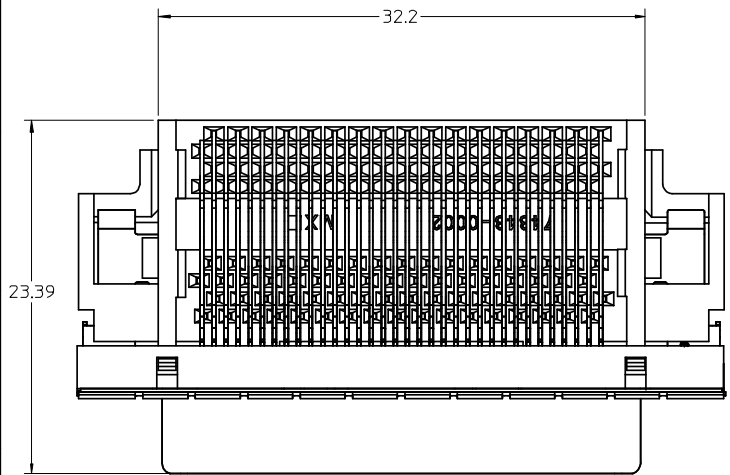

CLARIFY DIMENSIONS EC NO: UCP2008-1553 DRWN:BBARKER 2008/02/01 CHKD:DMORGAN 2008/02/07 APPR:SMILLER 2008/02/08		QUALITY SYMBOLS	WITHOUT COVER OPTION		SCALE	DESIGN UNITS	THIRD ANGLE PROJECTION	REVISE ON CAD ONLY
		$\nabla = 0$ $\sphericalangle = 0$	GENERAL TOLERANCES (UNLESS SPECIFIED)	4:1	METRIC			
REV	DESCRIPTION		mm	INCH	DIMENSION STYLE		TITLE	
			4 PLACES	± ---	± ---	MM ONLY		VHCI STACKED ASSEMBLY
			3 PLACES	± ---	± ---	DRAWN BY	DATE	
			2 PLACES	± 0.13	± ---	SSAMPSON	05.08.2001	
			1 PLACE	± 0.25	± ---	CHECKED BY	DATE	
				ANGULAR ± 1 °		MBANAKIS	05.08.2001	
			DRAFT WHERE APPLICABLE		APPROVED BY	DATE	MATERIAL NO.	DOCUMENT NO.
			MUST REMAIN WITHIN DIMENSIONS		MBANAKIS	05.08.2001	SEE TABLE	SD-74337-014
					THIS DRAWING CONTAINS INFORMATION THAT IS PROPRIETARY TO MOLEX INCORPORATED AND SHOULD NOT BE USED WITHOUT WRITTEN PERMISSION			

VERSION 1 PART NUMBERS

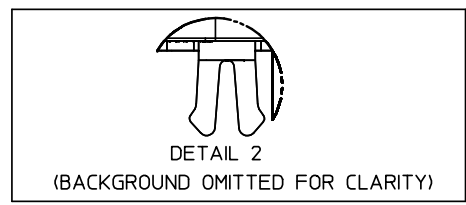

BOARD RETENTION: SNAP FIT

PCB THICKNESS	COVER	R DIM.	T DIM.	INCLUDES LOOSE PACKED SCREWLOCKS 71433-0002 SEE DRAWING SD-71433-005	GROUNDING TABS	PART NUMBER
1.60±0.16	YES	2.30	2.48	NO	YES	74337-0011
1.60±0.16	YES	2.08		NO	YES	74337-0012
1.60±0.16	NO	2.30	2.48	NO	YES	74337-0015
1.60±0.16	NO	2.08		NO	YES	74337-0016
1.60±0.16	YES	2.30	2.48	YES	YES	74337-0037
1.60±0.16	YES	2.08		YES	YES	74337-0038
1.60±0.16	NO	2.30	2.48	YES	YES	74337-0039
1.60±0.16	NO	2.08		YES	YES	74337-0040
2.36±0.16	YES	3.44	3.62	NO	YES	74337-0070
2.36±0.16	NO	3.44	3.62	NO	YES	74337-0071
2.36±0.16	YES	3.44	3.62	YES	YES	74337-0072
2.36±0.16	NO	3.44	3.62	YES	YES	74337-0073
1.60±0.16	YES	2.08		INSTALLED ON PART	YES	74337-1038

VERSION 4 PART NUMBERS

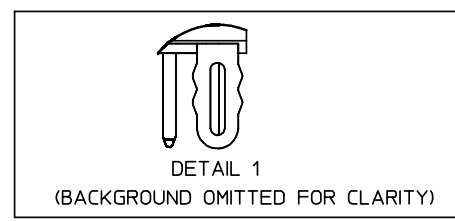

BOARD RETENTION: PRESS FIT

PCB THICKNESS	COVER	R DIM.	T DIM.	INCLUDES LOOSE PACKED SCREWLOCKS 71433-0002 SEE DRAWING SD-71433-005	GROUNDING TABS	PART NUMBER
1.60±0.16	YES	2.30	2.48	NO	YES	74337-0050
1.60±0.16	YES	2.08		NO	NO	74337-0051
1.60±0.16	NO	2.30	2.48	NO	YES	74337-0060
1.60±0.16	NO	2.08		NO	YES	74337-0061
1.60±0.16	YES	2.08		NO	YES	74337-0066
1.60±0.16	YES	2.30	2.48	YES	YES	74337-0053
1.60±0.16	YES	2.08		YES	YES	74337-0054
1.60±0.16	NO	2.30	2.48	YES	YES	74337-0063
1.60±0.16	NO	2.08		YES	YES	74337-0064
2.36±0.16	YES	3.44	3.62	NO	YES	74337-0052
2.36±0.16	NO	3.44	3.62	NO	YES	74337-0062
2.36±0.16	YES	3.44	3.62	YES	YES	74337-0055
2.36±0.16	NO	3.44	3.62	YES	YES	74337-0065
1.60±0.16	YES	2.08		INSTALLED ON PART	YES	74337-1054

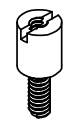

OPTIONAL SCREWLOCK
71433-0002

CLARIFY DIMENSIONS EC NO: UCP2008-1553 DRWN:BBARKER 2008/02/01 CHKD:DMORGAN 2008/02/07 APPR: SMILLER 2008/02/08	QUALITY SYMBOLS ▽ = 0 ▽ = 0	GENERAL TOLERANCES (UNLESS SPECIFIED) mm INCH 4 PLACES ± --- ± --- 3 PLACES ± --- ± --- 2 PLACES ± 0.13 ± --- 1 PLACE ± 0.25 ± --- ANGULAR ± 1°	SCALE 3:1 DESIGN UNITS METRIC DIMENSION STYLE MM ONLY	THIRD ANGLE PROJECTION REVISE ON CAD ONLY
	DRAFT WHERE APPLICABLE MUST REMAIN WITHIN DIMENSIONS	DRAWN BY SSAMPSON DATE 05.08.2001 CHECKED BY MBANAKIS DATE 05.08.2001 APPROVED BY MBANAKIS DATE 05.08.2001	TITLE VHDCI STACKED ASSEMBLY	MATERIAL NO. SEE TABLE DOCUMENT NO. SD-74337-014 SHEET NO. 3 OF 4
	THIS DRAWING CONTAINS INFORMATION THAT IS PROPRIETARY TO MOLEX INCORPORATED AND SHOULD NOT BE USED WITHOUT WRITTEN PERMISSION			
	MOLEX INCORPORATED			

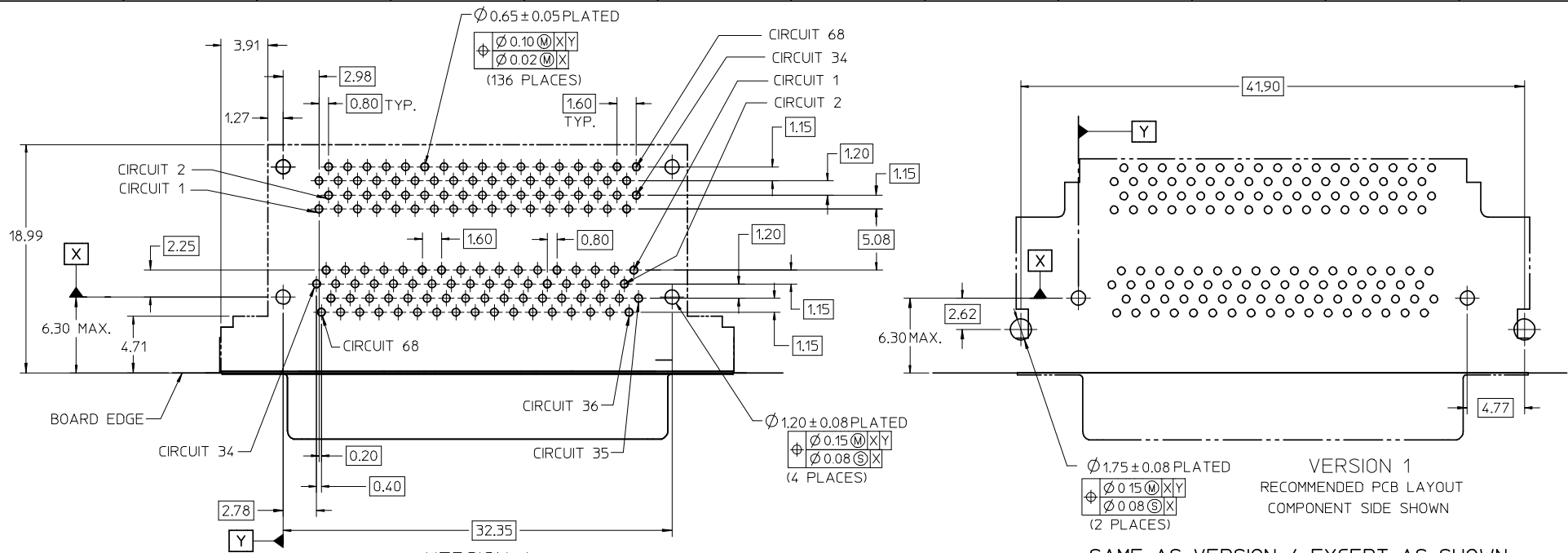

VERSION 4
RECOMMENDED PCB LAYOUT
COMPONENT SIDE SHOWN

VERSION 1
RECOMMENDED PCB LAYOUT
COMPONENT SIDE SHOWN
SAME AS VERSION 4 EXCEPT AS SHOWN

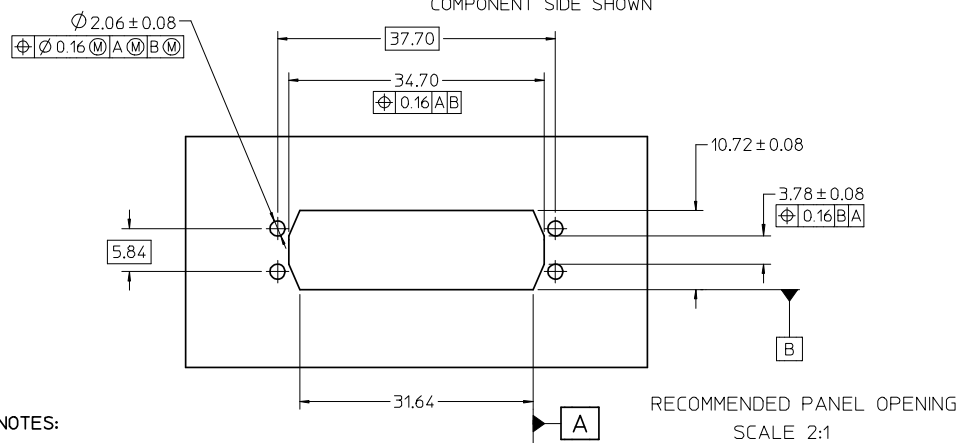

RECOMMENDED PANEL OPENING
SCALE 2:1

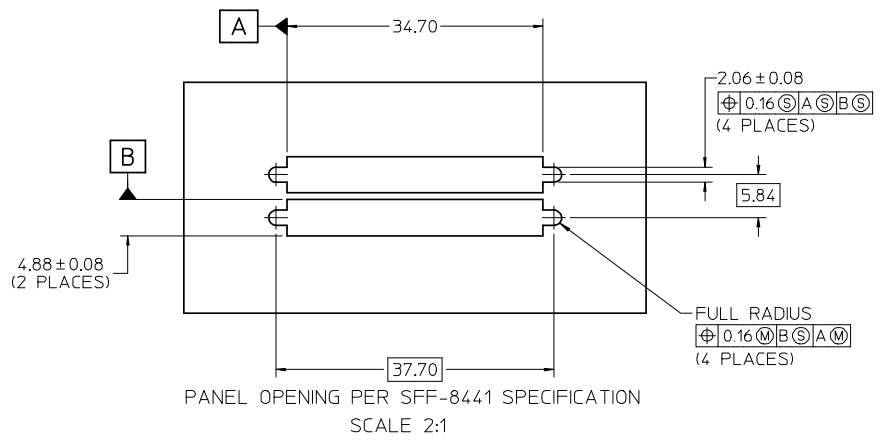

PANEL OPENING PER SFF-8441 SPECIFICATION
SCALE 2:1

NOTES:

- FOR FULL MATE WITH PLUG, PANEL THICKNESS SHOULD NOT EXCEED 1.0mm.
- FUNCTIONAL MATING WITH MOLEX PLUG CAN STILL BE MAINTAINED WITH PANELS AS THICK AS 2.5mm (BUT PLUG AND RECEPTACLE WILL NOT BE FULLY MATED).
- GUIDELINES FOR CHOOSING A MOLEX SCREWLOCK:

PANEL THICKNESS	RECOMMENDED SCREWLOCK
LESS THAN OR EQUAL TO 1.00 MM	71433-0002
1.01 TO 2.15 MM	71433-0010

CLARIFY DIMENSIONS EC NO: JCP2008-1553 DRWN:BBARKER 2008/02/01 CHKD:DMORGAN 2008/02/07 APPR:SMILLER 2008/02/08	QUALITY SYMBOLS ▽ - 0 ▽ - 0	GENERAL TOLERANCES (UNLESS SPECIFIED)		SCALE 3:1	DESIGN UNITS METRIC	THIRD ANGLE PROJECTION	REVISE ON CAD ONLY
		DIMENSION STYLE MM ONLY		DRAWN BY SSAMPSON DATE 05.08.2001		TITLE VHDCI STACKED ASSEMBLY	
		4 PLACES ± --- ± --- 3 PLACES ± --- ± --- 2 PLACES ± 0.13 ± --- 1 PLACE ± 0.25 ± ---		CHECKED BY MBANAKIS DATE 05.08.2001		MATERIAL NO. SEE TABLE DOCUMENT NO. SD-74337-014 SHEET NO. 4 OF 4	
		ANGULAR ± 1°		APPROVED BY MBANAKIS DATE 05.08.2001		MOLEX INCORPORATED	
DRAFT WHERE APPLICABLE MUST REMAIN WITHIN DIMENSIONS		THIS DRAWING CONTAINS INFORMATION THAT IS PROPRIETARY TO MOLEX INCORPORATED AND SHOULD NOT BE USED WITHOUT WRITTEN PERMISSION					