

SD

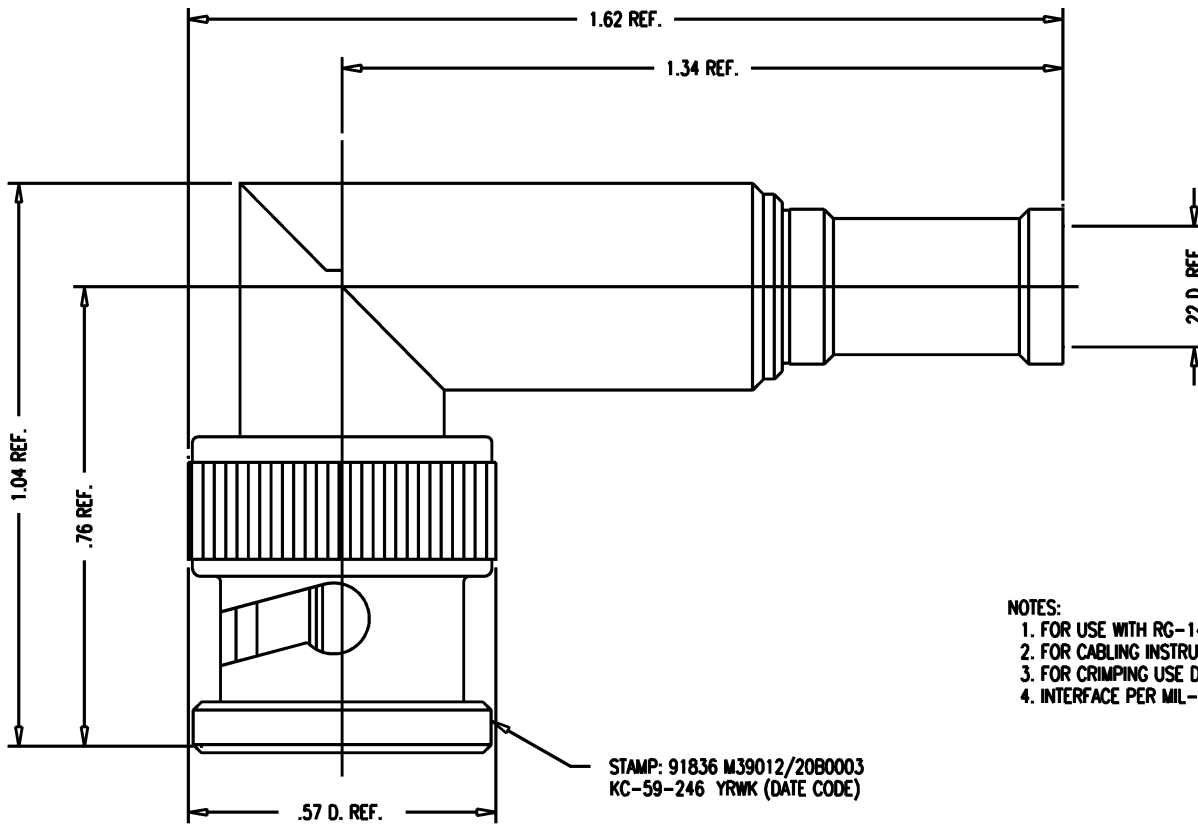

STAMP: 91836 M39012/20B0003
 KC-59-246 YRWK (DATE CODE)

- NOTES:
 1. FOR USE WITH RG-142, 223 & 400/U CABLE GROUPS.
 2. FOR CABLING INSTRUCTIONS SEE 3-334.
 3. FOR CRIMPING USE DIE KTH-2061.
 4. INTERFACE PER MIL-STD-348, FIG. 301-1.

M39012/20-0003

REVISIONS

ISSUE	CHANGES
0	ER 19662 CHC 09/12/79
1	CN 23169 E JEP 12/29/82
2	CN 23576 C GL 06/23/82
3	CN 26703 C SD 02/05/85
4	CN 27039 C SD 03/07/85
5	CN 28112 A SD 06/11/86
6	CN 30856 D MZB 05/17/89
7	CN 32297 A LNM 06/15/90
8	CN 37795 E REDRAWN TML 03/12/99
9	CN 39836 C PMC 3/13/07

KC59246

SCALE 4:1

APPROX SURFACE AREA

KC-59-246

USED ON

REF:

PLUG, ANG, BNC

DRAWN CHC	DATE 09/11/79
DESIGN HS	DATE 09/12/79
APPR.	DATE

KINGS
 ELECTRONICS CO., INC.
 ROCK HILL, SOUTH CAROLINA 29730

M39012/20-0003

SD