

**SOT₁NY™ Low Voltage SPDT Analog Switch
2:1 Mux/Demux Bus Switch**
Features

- CMOS Technology for Bus and Analog Applications
- Low ON Resistance: 8-ohms at 3.0V
- Wide V_{CC} Range: 1.65V to 5.5V
- Rail-to-Rail Signal Range
- Control Input Overvoltage Tolerance: 5.5V min.
- Fast Transition Speed: 5.2ns max. at 5V
- High Off Isolation: 57dB at 10MHz
- 54dB (10MHz) Crosstalk Rejection Reduces Signal Distortion
- Break-Before-Make Switching
- High Bandwidth: 250 MHz
- Extended Industrial Temperature Range: -40°C to 85°C
- Improved Direct Replacement for NC7SB3157
- Packaging (Pb-free & Green available):
 - 6-pin TDFN (ZA)
 - 6-pin SC70 (C)

Applications

- Cell Phones
- PDAs
- Portable Instrumentation
- Battery Powered Communications
- Computer Peripherals

Pin Description

Pin Number	Name	Description
1	B ₁	Data Port
2	GND	Ground
3	B ₀	Data Port (Normally Closed)
4	A	Common Output/Data Port
5	V _{CC}	Positive Power Supply
6	S	Logic Control

Logic Function Table

Logic Input (S)	Function
0	B ₀ Connected to A
1	B ₁ Connected to A

Description

The PI5A3157 is a high-bandwidth, fast single-pole double-throw (SPDT) CMOS switch. It can be used as an analog switch or as a low-delay bus switch. Specified over a wide operating power supply voltage range, 1.65V to 5.5V, the PI5A3157 has a maximum ON resistance of 12-ohms at 1.65V, 9-ohms at 2.3V & 6-ohms at 4.5V.

Break-before-make switching prevents both switches being enabled simultaneously. This eliminates signal disruption during switching.

The control input, S, tolerates input drive signals up to 5.5V, independent of supply voltage.

PI5A3157 is an improved direct replacement for the NC7SB3157.

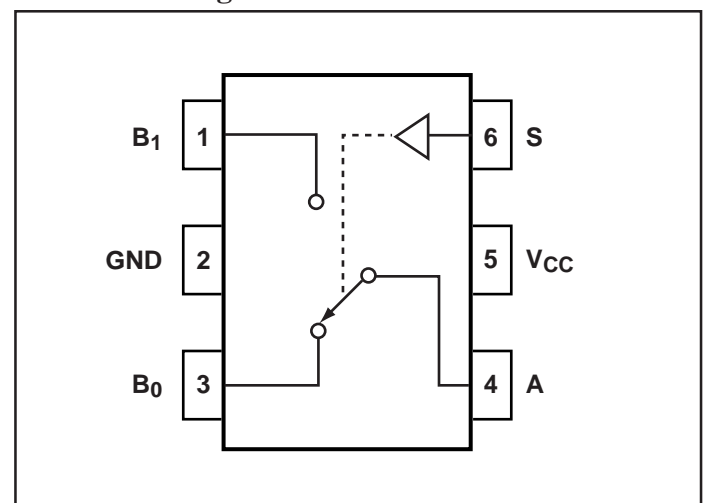
Connection Diagram



Absolute Maximum Ratings⁽¹⁾

Supply Voltage V_{CC}	-0.5V to +7V
DC Switch Voltage (V_S) ⁽²⁾	-0.5V to $V_{CC}+0.5V$
DC Input Voltage (V_{IN}) ⁽²⁾	-0.5V to +7.0V
DC Output Current (V_{OUT})	128mA
DC V_{CC} or Ground Current (I_{CC}/I_{GND})	$\pm 100mA$
Storage Temperature Range (T_{STG})	-65°C to +150°C
Junction Temperature under Bias (T_J)	150°C
Junction Lead Temperature (T_L) (Soldering, 10 seconds)	260°C
Power Dissipation (P_D) @ +85°C	180mW

Recommended Operating Conditions⁽³⁾

Supply Voltage Operating (V_{CC})	1.65V to 5.5V
Control Input Voltage (V_{IN})	0V to V_{CC}
Switch Input Voltage (V_{IN})	0V to V_{CC}
Output Voltage (V_{OUT})	0V to V_{CC}
Operating Temperature (T_A)	-40°C to +85°C
Input Rise and Fall Time (t_r, t_f) Control Input $V_{CC} = 2.3V - 3.6V$	0ns/V to 10ns/V
Control Input $V_{CC} = 4.5V - 5.5V$	0ns/V to 5ns/V
Thermal Resistance (θ_{JA})	350°C/W

Notes

1. Absolute Maximum Ratings” may cause permanent damage to the device. This is a stress only rating and operation of the device at these or any other conditions beyond those indicated in the operational sections of this specification is not implied.
2. The input and output negative voltage ratings may be exceeded if the input and output diode current ratings are observed.
3. Control input must be held HIGH or LOW; it must not float.

DC Electrical Characteristics (Over the Operating temperature range, $T_A = -40^\circ C$ to $85^\circ C$)

Parameter	Description	Test Conditions	Supply Voltage	Temp (°C)	Min.	Typ	Max.	Units	
V_{IAR}	Analog Input Signal Range		V_{CC}	$T_A = 25^\circ C$ & -40°C to 85°C	0		V_{CC}	V	
R_{ON}	ON Resistance ⁽⁴⁾	$I_O = 30mA, V_{IN} = 0V$	4.5V	$T_A = 25^\circ C$		4	6	Ω	
		$I_O = -30mA, V_{IN} = 2.4V$				5	8		
		$I_O = -30mA, V_{IN} = 4.5V$				8	13		
R_{ON}		$I_O = 30mA, V_{IN} = 0V$	4.5V	$T_A = -40^\circ C$ to 85°C					6
		$I_O = -30mA, V_{IN} = 2.4V$					8		
		$I_O = -30mA, V_{IN} = 4.5V$					13		
R_{ON}		$I_O = 24mA, V_{IN} = 0V$	3.0V	$T_A = 25^\circ C$		5	8		
		$I_O = -24mA, V_{IN} = 3.0V$				12	19		
R_{ON}		$I_O = 24mA, V_{IN} = 0V$	3.0V	$T_A = -40^\circ C$ to 85°C			8		
		$I_O = -24mA, V_{IN} = 3.0V$					19		
R_{ON}		$I_O = 8mA, V_{IN} = 0V$	2.3V	$T_A = 25^\circ C$		6	9		
		$I_O = -8mA, V_{IN} = 2.3V$				16	24		
R_{ON}	$I_O = 30mA, V_{IN} = 0V$	2.3V	$T_A = -40^\circ C$ to 85°C			9			
	$I_O = -30mA, V_{IN} = 2.4V$					24			
R_{ON}	$I_O = 4mA, V_{IN} = 0V$	1.65V	$T_A = 25^\circ C$		8	12			
	$I_O = -4mA, V_{IN} = 1.65V$				27	39			
R_{ON}	$I_O = 4mA, V_{IN} = 0V$	1.65V	$T_A = -40^\circ C$ to 85°C			12			
	$I_O = -4mA, V_{IN} = 1.65V$					39			

DC Electrical Characteristics (Over the Operating temperature range, $T_A = -40^\circ\text{C}$ to 85°C) (continued)

Parameter	Description	Test Conditions	Supply Voltage	Temp (°C)	Min.	Typ	Max.	Units
ΔR_{ON}	ON Resistance Match Between Channels ^(4,5,6)	$I_A = -30\text{mA}$, $V_{Bn} = 3.15\text{V}$	4.5V	$T_A = 25^\circ\text{C}$		0.15		Ω
		$I_A = -24\text{mA}$, $V_{Bn} = 2.1\text{V}$	3.0V			0.2		
		$I_A = -8\text{mA}$, $V_{Bn} = 1.6\text{V}$	2.3V			0.3		
		$I_A = -4\text{mA}$, $V_{Bn} = 1.15\text{V}$	1.65V			0.3		
R_{ONF}	ON Resistance Flatness ^(4,5,7)	$I_A = -30\text{mA}$, $0 \leq V_{Bn} \leq V_{CC}$	5.0V	$T_A = 25^\circ\text{C}$		6		Ω
		$I_A = -24\text{mA}$, $0 \leq V_{Bn} \leq V_{CC}$	3.3V			12		
		$I_A = -8\text{mA}$, $0 \leq V_{Bn} \leq V_{CC}$	2.5V			22		
		$I_A = -4\text{mA}$, $0 \leq V_{Bn} \leq V_{CC}$	1.8V			90		
V_{IH}	Input High Voltage	Logic High Level	$V_{CC} = 1.65\text{V}$ to 1.95V	$T_A = 25^\circ\text{C}$ & -40°C to 85°C	$0.75V_{CC}$			V
			$V_{CC} = 2.3\text{V}$ to 5.5V		$0.7V_{CC}$			
V_{IL}	Input Low Voltage	Logic Low Level	$V_{CC} = 1.65\text{V}$ to 1.95V				$0.25V_{CC}$	V
			$V_{CC} = 2.3\text{V}$ to 5.5V				$0.25V_{CC}$	
	Input Leakage Current	$0 \leq V_{IN} \leq 5.5\text{V}$	$V_{CC} = 0\text{V}$ to 5.5V	$T_A = 25^\circ\text{C}$			± 0.1	
				$T_A = -40^\circ\text{C}$ to 85°C			± 1.0	
I_{OFF}	OFF State Leakage Current	$0 \leq V_{IN} \leq 5.5\text{V}$	$V_{CC} = 1.65\text{V}$ to 5.5V	$T_A = 25^\circ\text{C}$			± 0.1	μA
				$T_A = -40^\circ\text{C}$ to 85°C			± 10	
I_{CC}	Quiescent Supply Current	All channels ON or OFF, $V_{IN} = V_{CC}$ or GND, $I_{OUT} = 0$	$V_{CC} = 5.5\text{V}$	$T_A = 25^\circ\text{C}$			1	
				$T_A = -40^\circ\text{C}$ to 85°C			10	

Notes:

4. Measured by voltage drop between A and B pins at the indicated current through the device. ON resistance is determined by the lower of the voltages on two ports (A or B).
5. Parameter is characterized but not tested in production.
6. $\Delta R_{ON} = R_{ON\text{ max}} - R_{ON\text{ min}}$. measured at identical V_{CC} , temperature and voltage levels.
7. Flatness is defined as difference between maximum and minimum value of ON resistance over the specified range of conditions.
8. Guaranteed by design.

Capacitance⁽¹²⁾

Parameter	Description	Test Conditions	Supply Voltage	Temp (°C)	Min.	Typ	Max.	Units
C_{IN}	Control Input	$f = 1\text{ MHz}^{(12)}$	$V_{CC} = 5.0\text{V}$	$T_A = 25^\circ\text{C}$		2.3		pF
C_{IO-B}	For B Port, Switch OFF					6.5		
C_{IOA-ON}	For A Port, Switch ON					18.5		

Switch and AC Characteristics

Parameter	Description	Test Conditions	Supply Voltage	Temp (°C)	Min.	Typ	Max.	Units
t _{PLH} t _{PHL}	Propagation Delay: A to Bn	See test circuit diagrams 1 and 2. V _I Open ⁽¹⁰⁾	V _{CC} = 2.3V to 2.7V	T _A = 25°C & -40 to 85°C		1.2		
			V _{CC} = 3.0V to 3.6V			0.8		
			V _{CC} = 4.5V to 5.5V			0.3		
t _{PZL} t _{PZH}	Output Enable Turn ON Time: A to Bn	See test circuit diagrams 1 & 2. V _I = 2V _{CC} for t _{PZL} , V _I = 0V for t _{PZH}	V _{CC} = 1.65V to 1.95V	T _A = 25°C		7	23	
			V _{CC} = 2.3V to 2.7V			3.5	13	
			V _{CC} = 3.0V to 3.6V			2.5	6.9	
			V _{CC} = 4.5V to 5.5V			1.7	5.2	
t _{PZL} t _{PZH}	OUTPUT ENABLE TURN ON TIME: A TO Bn	See test circuit diagrams 1 and 2. V _I = 2V _{CC} for t _{PZL} , V _I = 0V for t _{PZH}	V _{CC} = 2.5V	T _A = 25°C & -40 to 85°C			24	
			V _{CC} = 3.3V				14	
			V _{CC} = 3.0V to 3.6V				7.6	
			V _{CC} = 4.5V to 5.5V				5.7	
t _{PLZ} t _{PHZ}	Output Disable Turn OFF Time: A to Bn	See test circuit diagrams 1 and 2. V _I = 2V _{CC} for t _{PLZ} , V _I = 0V for t _{PHZ}	V _{CC} = 1.65V to 1.95V	T _A = 25°C		3	12.5	ns
			V _{CC} = 2.3V to 2.7V			2	7	
			V _{CC} = 3.0V to 3.6V			1.5	5	
			V _{CC} = 4.5V to 5.5V			0.8	3.5	
t _{PLZ} t _{PHZ}	Output Disable Turn OFF Time: A to Bn	See test circuit diagrams 1 and 2. V _I = 2V _{CC} for t _{PLZ} , V _I = 0V for t _{PHZ}	V _{CC} = 2.5V	T _A = -40 to 85°C			13	
			V _{CC} = 3.3V				7.5	
			V _{CC} = 3.0V to 3.6V				5.3	
			V _{CC} = 4.5V to 5.5V				3.8	
t _{BM}	Break Before Make Time	See test circuit diagram 9. ⁽⁹⁾	V _{CC} = 2.5V	T _A = 25°C & -40 to 85°C		0.5		
			V _{CC} = 3.3V			0.5		
			V _{CC} = 3.0V to 3.6V			0.5		
			V _{CC} = 4.5V to 5.5V			0.5		
Q	Charge Injection	C _L = 0.1nF, V _{GEN} = 0V, R _{GEN} = 0Ω. See test circuit 4.	V _{CC} = 5.0V	T _A = 25°C		7		pC
			V _{CC} = 3.3V			3		
OIRR	Off Isolation	R _L = 50Ω, V _{GEN} = 0V, R _{GEN} = 0Ω. See test circuit 5. ⁽¹¹⁾	V _{CC} = 1.65V to 5.5V	T _A = 25°C		-57		dB
X _{TALK}	Crosstalk Isolation	See test circuit 6.	V _{CC} = 1.65V to 5.5V	T _A = 25°C		-54		
f _{3dB}	-3dB Bandwidth	See test circuit 9	V _{CC} = 1.65V to 5.5V	T _A = 25°C		250		MHz

Notes:

9. Guaranteed by design.
10. Guaranteed by design but not production tested. The device contributes no other propagation delay other than the RC delay of the switch ON resistance and the 50pF load capacitance, when driven by an ideal voltage source with zero output impedance.
11. Off Isolation = 20 Log₁₀ [V_A / V_{Bn}] and is measured in dB.
12. T_A = 25°C, f = 1MHz. Capacitance is characterized but not tested in production.

Test Circuits and Timing Diagrams

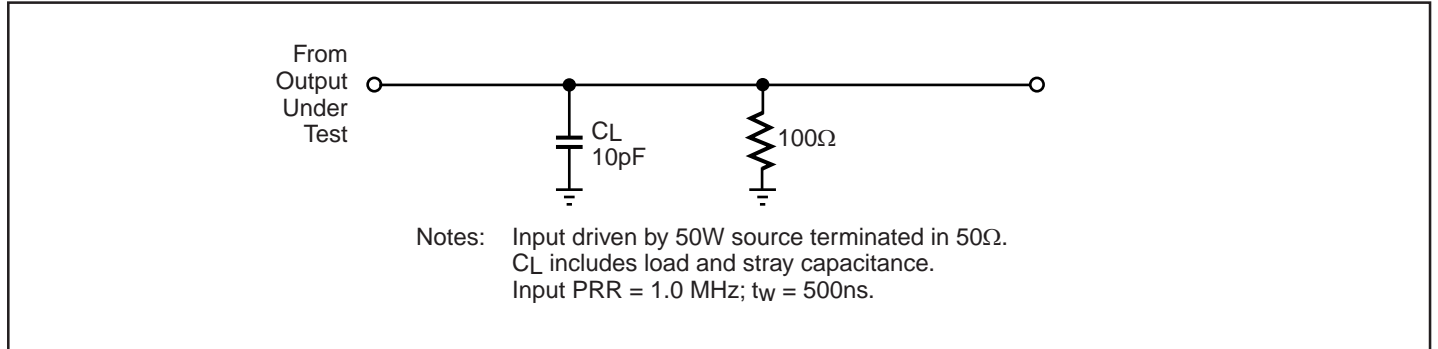

Figure 1. AC Test Circuit

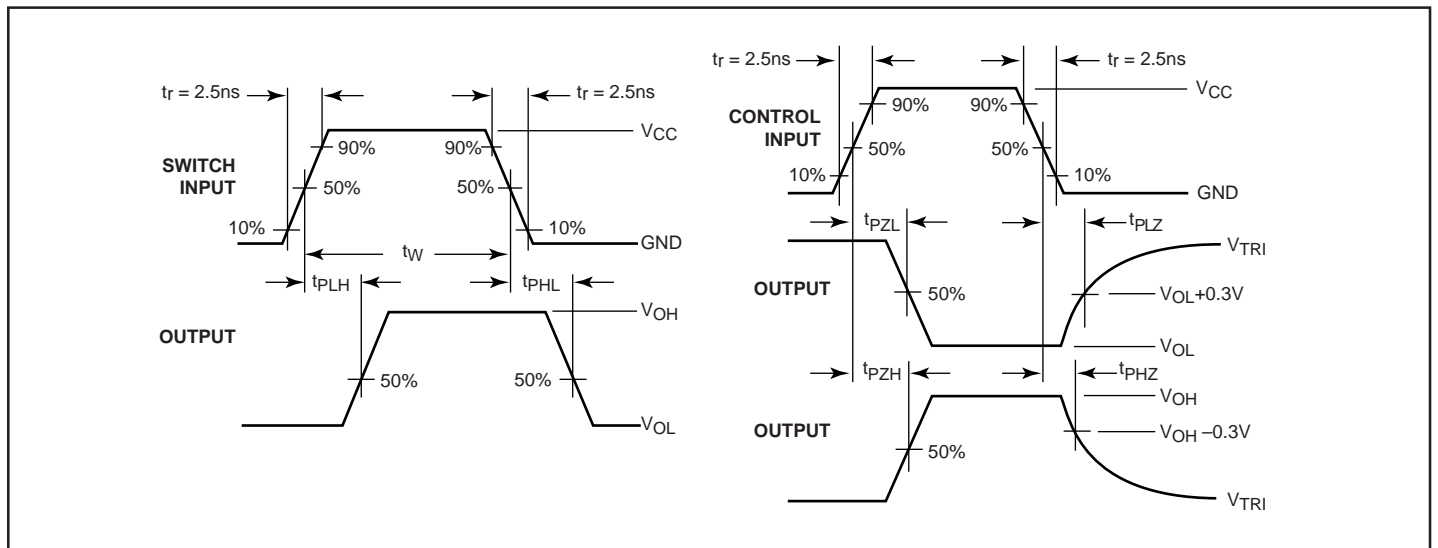

Figure 2. AC Waveforms

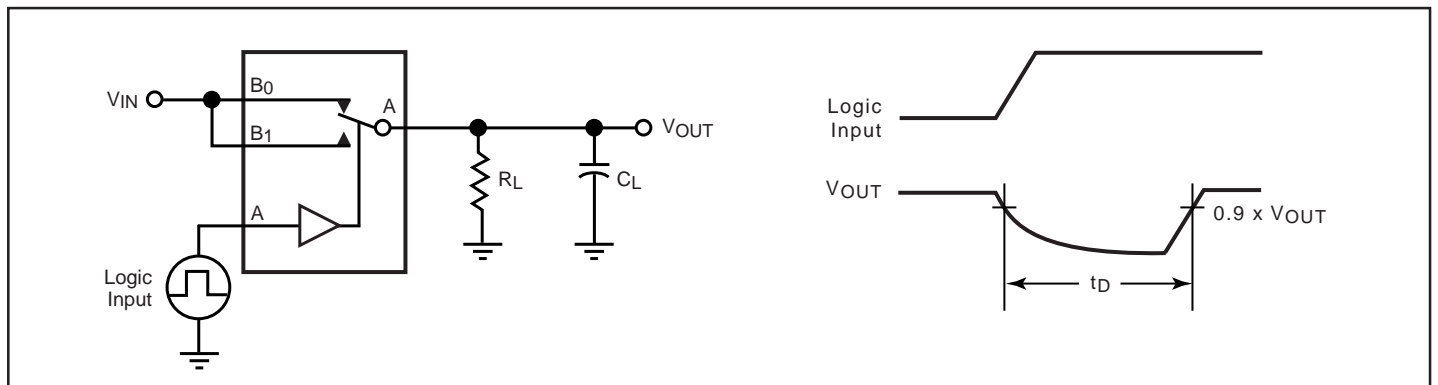

Figure 3. Break Before Make Interval Timing

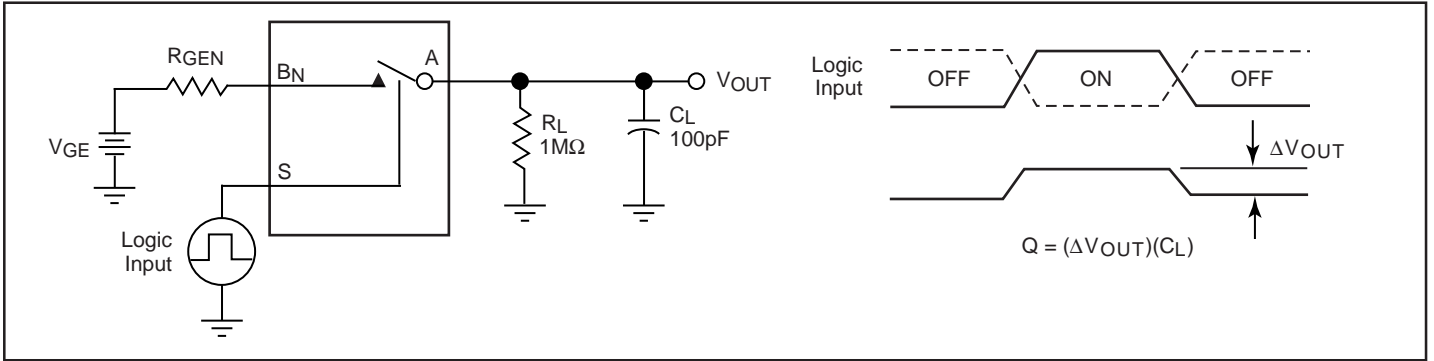

Figure 4. Charge Injection Test

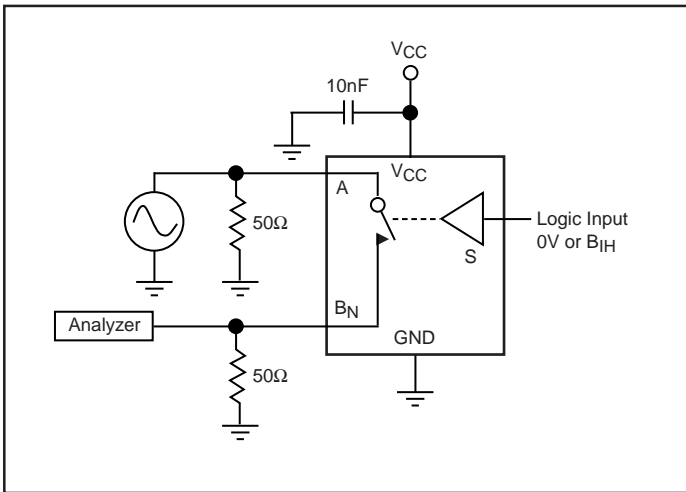

Figure 5. Off Isolation

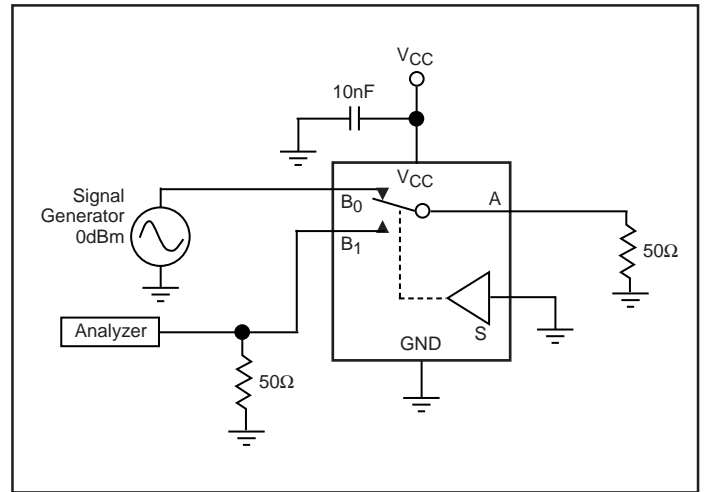

Figure 6. Crosstalk

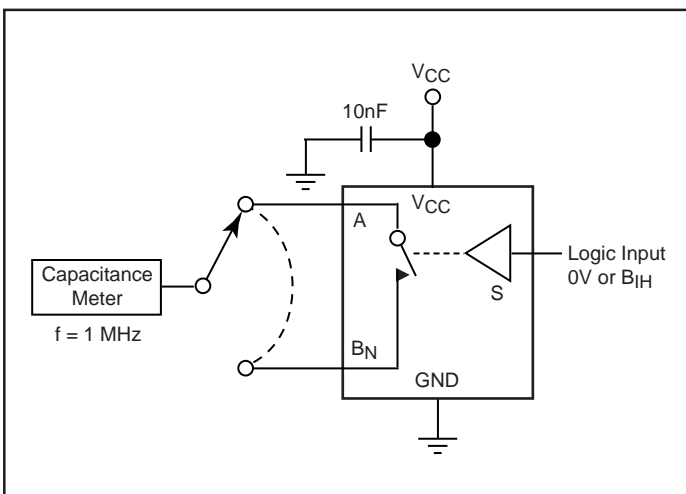

Figure 7. Channel Off Capacitance

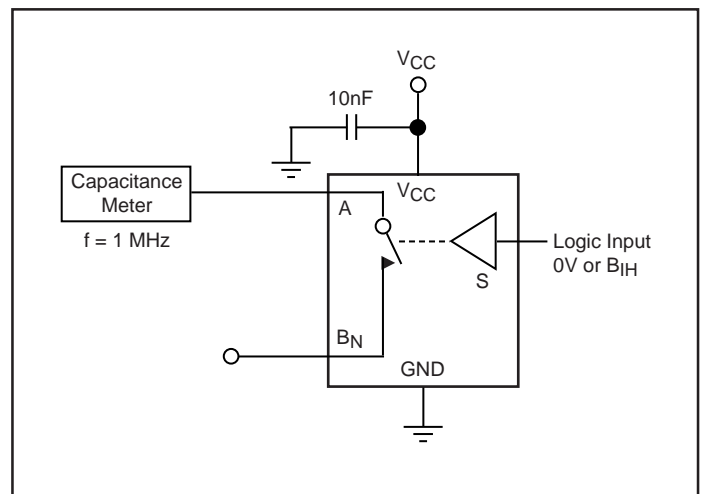

Figure 8. Channel On Capacitance

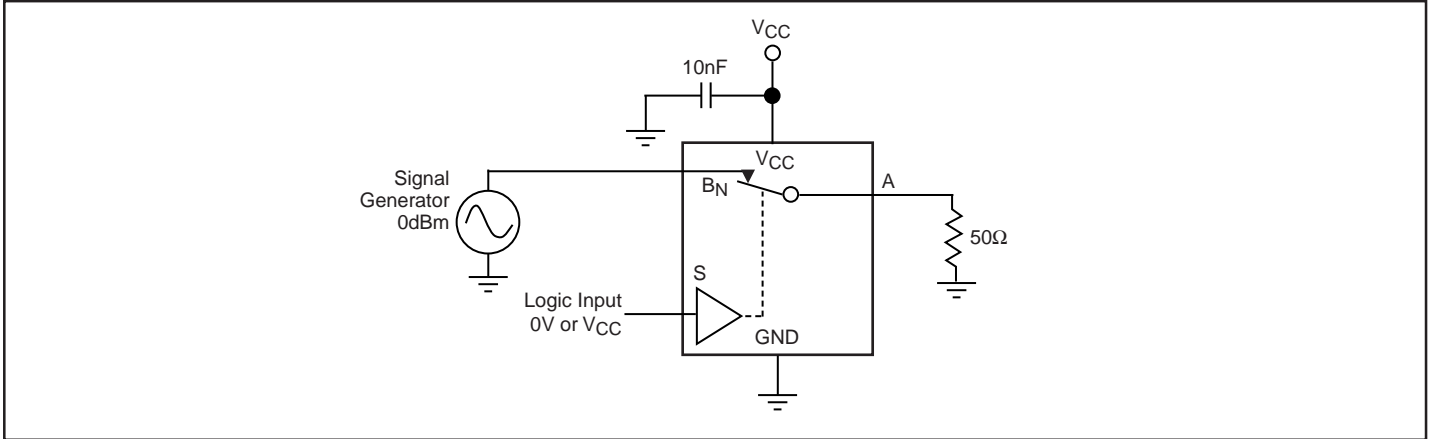
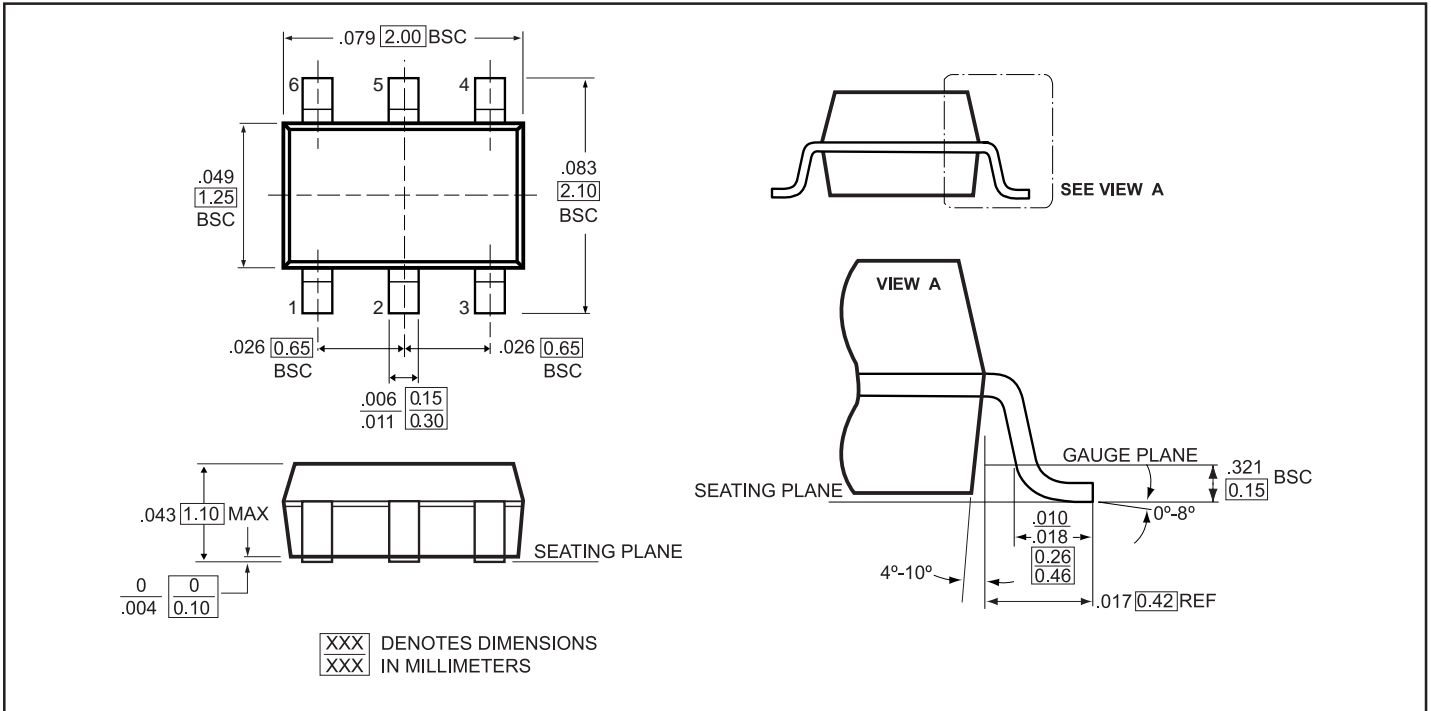
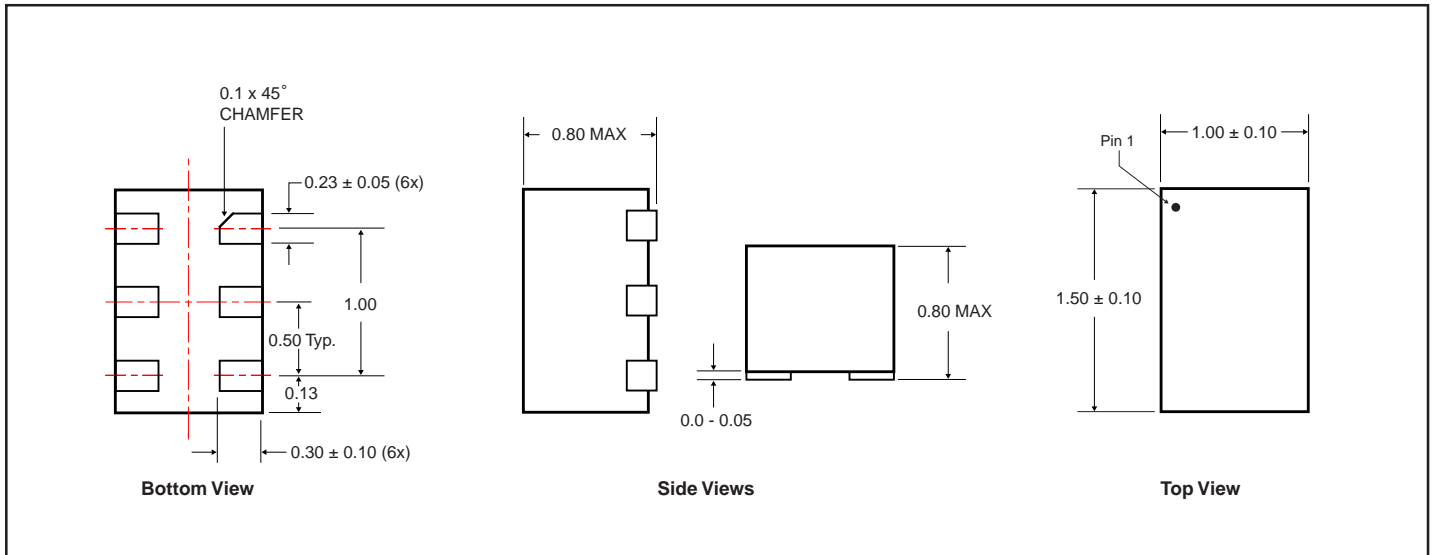

Figure 9. Bandwidth

Packaging Mechanical: 6-Pin SC70 (C)



Packaging Mechanical: 6-Pin TDFN (ZA)



Ordering Information

Ordering Code	Package Code	Package Description	Top Marking
PI5A3157CX	C	6-pin SC70	ZM
PI5A3157CEX	C	Pb-free & Green 6-pin SC70	ZM
PI5A3157ZAEX	ZA	Pb-free & Green 6-contact TDFN	\overline{ZM}

Notes:

1. Thermal characteristics can be found on the company web site at www.pericom.com/packaging/
2. X = Tape and reel