

MC74VHC1G66

Single Supply Analog Switch

The MC74VHC1G66 is an advanced high speed CMOS bilateral analog switch fabricated with silicon gate CMOS technology. It achieves high speed propagation delays and low ON resistances while maintaining low power dissipation. This bilateral switch controls analog and digital voltages that may vary across the full power-supply range (from V_{CC} to GND).

The MC74VHC1G66 is compatible in function to a single gate of the High Speed CMOS MC74VHC4066. The device has been designed so the ON resistances (R_{ON}) are lower and more linear over input voltage.

The ON/OFF control inputs are compatible with standard CMOS outputs. The ON/OFF control input structure provides protection when voltages between 0 V and 5.5 V are applied, regardless of the supply voltage. This input structure helps prevent device destruction caused by supply voltage – input/output voltage mismatch, battery backup, hot insertion, etc.

- High Speed: $t_{PD} = 20$ ns (Typ) at $V_{CC} = 5.0$ V
- Low Power Dissipation: $I_{CC} = 1$ μ A (Max) at $T_A = 25^\circ$ C
- Diode Protection Provided on Inputs and Outputs
- Improved Linearity and Lower ON Resistance over Input Voltage
- Chip Complexity: 11 FETs or 3 Equivalent Gates
- ON/OFF Control Input has OVT
- Chip Complexity: FETs = 11

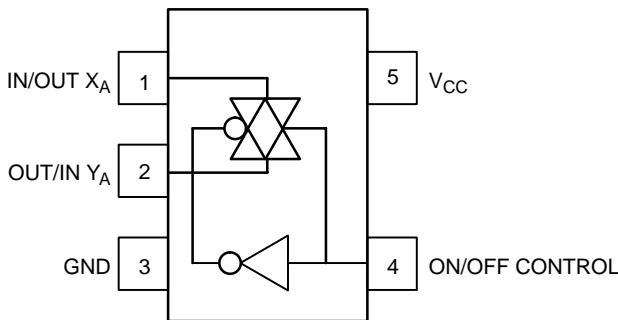

Figure 1. Pinout

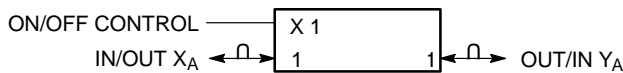

Figure 2. Logic Symbol



ON Semiconductor®

<http://onsemi.com>



SC70-5/SC-88A/SOT-353
DF SUFFIX
CASE 419A

MARKING DIAGRAMS

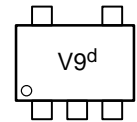

Pin 1

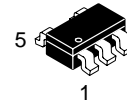

SOT23-5/TSOP-5/SC59-5
DT SUFFIX
CASE 483

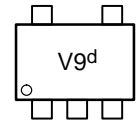

Pin 1

d = Date Code

PIN ASSIGNMENT

1	IN/OUT X_A
2	OUT/IN Y_A
3	GND
4	ON/OFF CONTROL
5	V_{CC}

FUNCTION TABLE

On/Off Control Input	State of Analog Switch
L	Off
H	On

ORDERING INFORMATION

See detailed ordering and shipping information in the package dimensions section on page 6 of this data sheet.

MC74VHC1G66

MAXIMUM RATINGS

Symbol	Characteristics	Value	Unit	
V _{CC}	DC Supply Voltage	-0.5 to +7.0	V	
V _{IN}	Digital Input Voltage	-0.5 to +7.0	V	
V _{IS}	Analog Output Voltage	-0.5 to V _{CC} +0.5	V	
I _{IK}	Digital Input Diode Current	-20	mA	
I _{CC}	DC Supply Current, V _{CC} and GND	+25	mA	
T _{STG}	Storage Temperature Range	-65 to +150	°C	
T _L	Lead Temperature, 1 mm from Case for 10 Seconds	260	°C	
T _J	Junction Temperature Under Bias	+150	°C	
θ _{JA}	Thermal Resistance	SC70-5/SC-88A/SOT-353 (Note 1) SOT23-5/TSOP-5/SC59-5	350 230	°C/W
P _D	Power Dissipation in Still Air at 85°C	SC70-5/SC-88A/SOT-353 SOT23-5/TSOP-5/SC59-5	150 200	mW
MSL	Moisture Sensitivity	Level 1		
F _R	Flammability Rating	Oxygen Index: 28 to 34	UL 94 V-0 @ 0.125 in	
V _{ESD}	ESD Withstand Voltage	Human Body Model (Note 2) Machine Model (Note 3) Charged Device Model (Note 4)	> 2000 > 200 N/A	V
I _{LATCH-UP}	Latch-Up Performance	Above V _{CC} and Below GND at 125°C (Note 5)	± 500	mA

Maximum Ratings are those values beyond which damage to the device may occur. Exposure to these conditions or conditions beyond those indicated may adversely affect device reliability. Functional operation under absolute-maximum-rated conditions is not implied. Functional operation should be restricted to the Recommended Operating Conditions.

1. Measured with minimum pad spacing on an FR4 board, using 10 mm-by-1 inch, 2-ounce copper trace with no air flow.
2. Tested to EIA/JESD22-A114-A.
3. Tested to EIA/JESD22-A115-A.
4. Tested to JESD22-C101-A.
5. Tested to EIA/JESD78.

RECOMMENDED OPERATING CONDITIONS

Symbol	Characteristics	Min	Max	Unit
V _{CC}	DC Supply Voltage	2.0	5.5	V
V _{IN}	DC Input Voltage	GND	5.5	V
V _{IS}	DC Output Voltage	GND	V _{CC}	V
T _A	Operating Temperature Range	-55	+125	°C
t _r , t _f	Input Rise and Fall Time ON/OFF Control Input	V _{CC} = 3.3 V ± 0.3 V V _{CC} = 5.0 V ± 0.5 V	0 100 20	ns/V

DEVICE JUNCTION TEMPERATURE VERSUS TIME TO 0.1% BOND FAILURES

Junction Temperature °C	Time, Hours	Time, Years
80	1,032,200	117.8
90	419,300	47.9
100	178,700	20.4
110	79,600	9.4
120	37,000	4.2
130	17,800	2.0
140	8,900	1.0

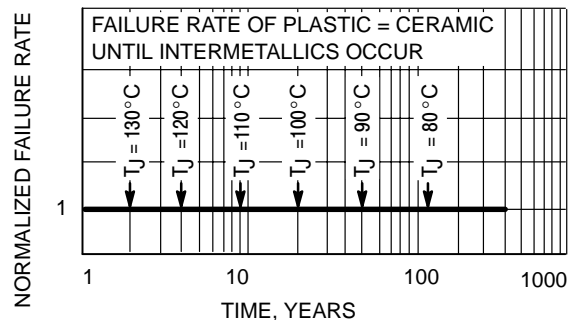

Figure 3. Failure Rate vs. Time Junction Temperature

MC74VHC1G66

DC ELECTRICAL CHARACTERISTICS

Symbol	Parameter	Test Conditions	V _{CC} (V)	T _A = 25°C		T _A ≤ 85°C		-55 ≤ T _A ≤ 125°C		Unit	
				Min	Max	Min	Max	Min	Max		
V _{IH}	Minimum High-Level Input Voltage ON/OFF Control Input	R _{ON} = Per Spec	2.0 3.0 4.5 5.5	1.5 2.1 3.15 3.85		1.5 2.1 3.15 3.85		1.5 2.1 3.15 3.85		V	
V _{IL}	Maximum Low-Level Input Voltage ON/OFF Control Input	R _{ON} = Per Spec	2.0 3.0 4.5 5.5		0.5 0.9 1.35 1.65		0.5 0.9 1.35 1.65		0.5 0.9 1.35 1.65		V
I _{IN}	Maximum Input Leakage Current ON/OFF Control Input	V _{IN} = V _{CC} or GND	0 to 5.5		±0.1		±1.0		±1.0		μA
I _{CC}	Maximum Quiescent Supply Current	V _{IN} = V _{CC} or GND V _{IO} = 0 V	5.5		1.0		20		40		μA
R _{ON}	Maximum "ON" Resistance	V _{IN} = V _{IH} V _{IS} = V _{CC} or GND I _{IS} ≤ 5 mA (Figure 1)	3.0 4.5 5.5		60 45 40		70 50 45		100 60 55		Ω
I _{OFF}	Maximum Off-Channel Leakage Current	V _{IN} = V _{IL} V _{IS} = V _{CC} or GND Switch Off (Figure 2)	5.5		0.1		0.5		1.0		μA

AC ELECTRICAL CHARACTERISTICS C_{load} = 50 pF, Input t_r/t_f = 3.0 ns

Symbol	Parameter	Test Conditions	V _{CC} (V)	T _A = 25°C			T _A ≤ 85°C		-55 ≤ T _A ≤ 125°C		Unit
				Min	Typ	Max	Min	Max	Min	Max	
t _{PLH} , t _{PHL}	Maximum Propagation Delay, Input X to Y	Y _A = Open Figure 14	2.0 3.0 4.5 5.5		1 0.6 0.6 0.6	5 2 1 1		6 3 1 1		7 4 2 1	ns
t _{PLZ} , t _{PHZ}	Maximum Propagation Delay, ON/OFF Control to Analog Output	R _L = 1000 Ω Figure 15	2.0 3.0 4.5 5.5		32 28 24 20	40 35 30 25		45 40 35 30		50 45 40 35	ns
t _{PZL} , t _{PZH}	Maximum Propagation Delay, ON/OFF Control to Analog Output	R _L = 1000 Ω Figure 15	2.0 3.0 4.5 5.5		32 28 24 20	40 35 30 25		45 40 35 30		50 45 40 35	ns
C _{IN}	Maximum Input Capacitance	ON/OFF Control Input	0.0		3	10		10		10	pF
		Control Input = GND Analog I/O Feedthrough	5.0		4 4	10 10		10 10		10 10	
C _{PD}	Power Dissipation Capacitance (Note 6)	Typical @ 25°C, V_{CC} = 5.0 V								pF	
								18			

6. C_{PD} is defined as the value of the internal equivalent capacitance which is calculated from the operating current consumption without load. Average operating current can be obtained by the equation: I_{CC(OPR)} = C_{PD} • V_{CC} • f_{in} + I_{CC}. C_{PD} is used to determine the no-load dynamic power consumption; P_D = C_{PD} • V_{CC}² • f_{in} + I_{CC} • V_{CC}.

MC74VHC1G66

ADDITIONAL APPLICATION CHARACTERISTICS (Voltages Referenced to GND Unless Noted)

Symbol	Parameter	Test Conditions	V _{CC}	Limit 25°C	Unit
BW	Maximum On-Channel Bandwidth or Minimum Frequency Response Figure 7	f _{in} = 1 MHz Sine Wave Adjust f _{in} voltage to obtain 0 dBm at V _{OS} Increase f _{in} = frequency until dB meter reads -3 dB R _L = 50 Ω, C _L = 10 pF	3.0 4.5 5.5	150 175 180	MHz
ISO _{off}	Off-Channel Feedthrough Isolation Figure 8	f _{in} = Sine Wave Adjust f _{in} voltage to obtain 0 dBm at V _{IS} f _{in} = 10 kHz, R _L = 600 Ω, C _L = 50 pF	3.0 4.5 5.5	-80 -80 -80	dB
NOISE _{feed}	Feedthrough Noise Control to Switch Figure 9	V _{in} ≤ 1 MHz Square Wave (t _r = t _f = 2 ns) R _L = 600 Ω, C _L = 50 pF	3.0 4.5 5.5	45 60 130	mV _{PP}
THD	Total Harmonic Distortion Figure 10	f _{in} = 1 kHz, R _L = 10 kΩ, C _L = 50 pF THD = THD _{Measured} - THD _{Source} V _{IS} = 3.0 V _{PP} sine wave V _{IS} = 5.0 V _{PP} sine wave	3.3 5.5	0.30 0.15	%

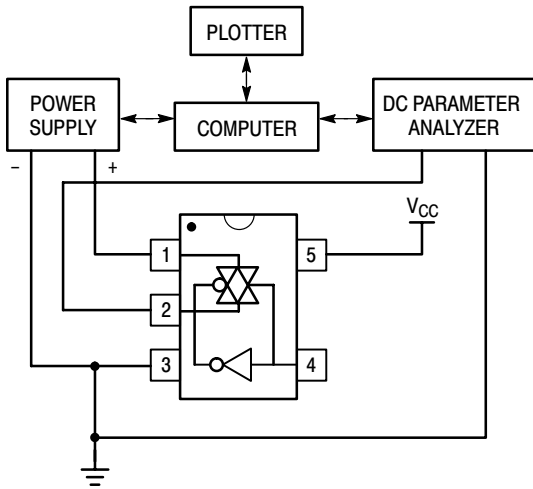

Figure 4. On Resistance Test Set-Up

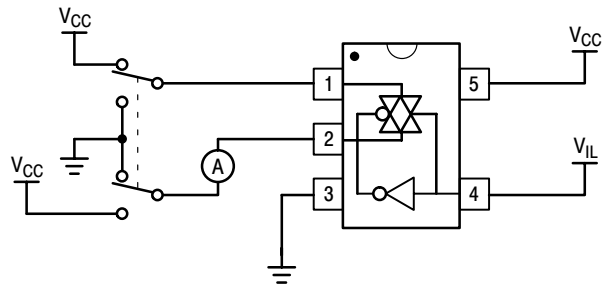

Figure 5. Maximum Off-Channel Leakage Current Test Set-Up

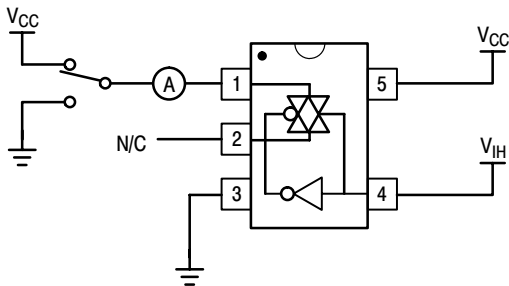

Figure 6. Maximum On-Channel Leakage Current Test Set-Up

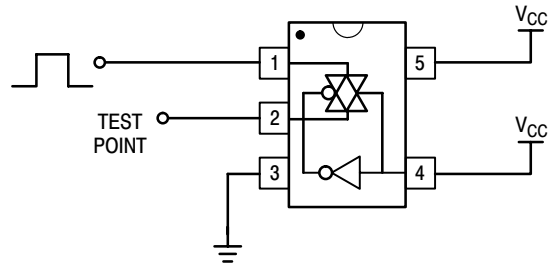

Figure 7. Propagation Delay Test Set-Up

MC74VHC1G66

Switch to Position 2 when testing t_{PLZ} and t_{PZL}
 Switch to Position 1 when testing t_{PHZ} and t_{PZH}

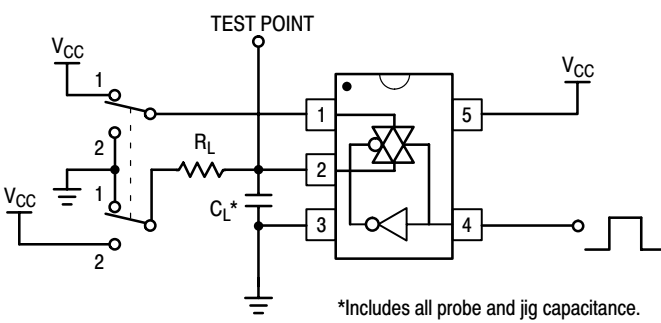

Figure 8. Propagation Delay Output Enable/Disable Test Set-Up

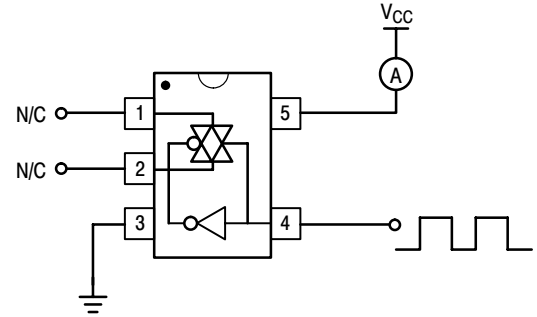

Figure 9. Power Dissipation Capacitance Test Set-Up

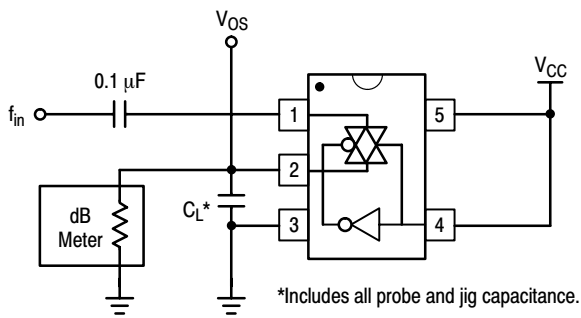

Figure 10. Maximum On-Channel Bandwidth Test Set-Up

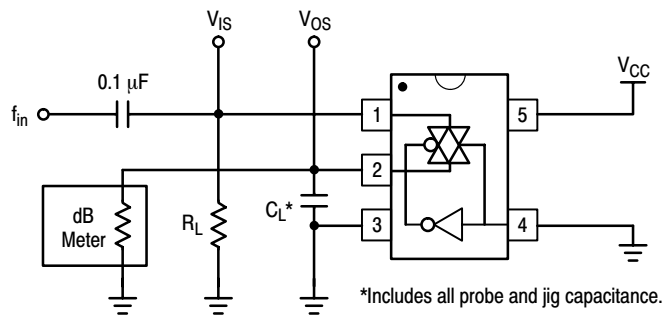

Figure 11. Off-Channel Feedthrough Isolation Test Set-Up

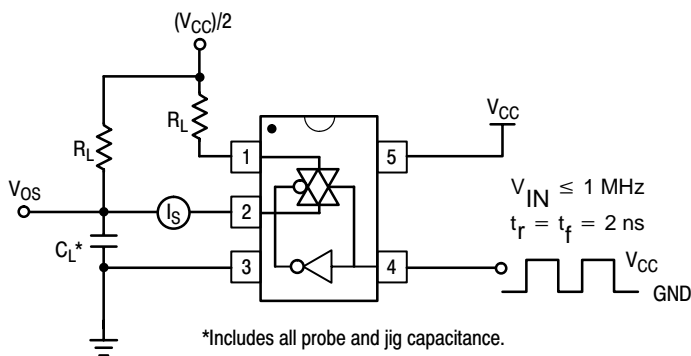

Figure 12. Feedthrough Noise, ON/OFF Control to Analog Out, Test Set-Up

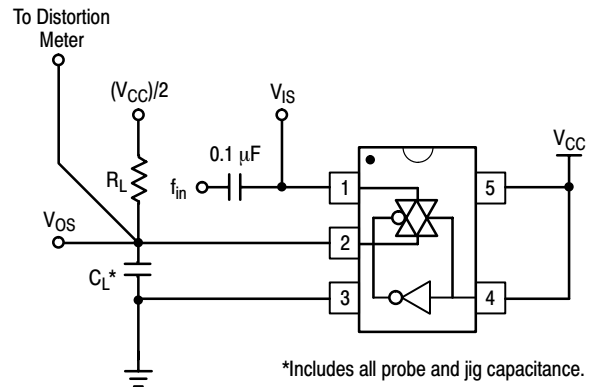

Figure 13. Total Harmonic Distortion Test Set-Up

MC74VHC1G66

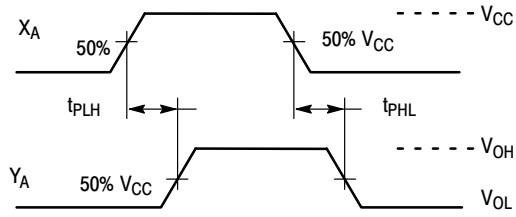

Figure 14. Propagation Delay, Analog In to Analog Out Waveforms

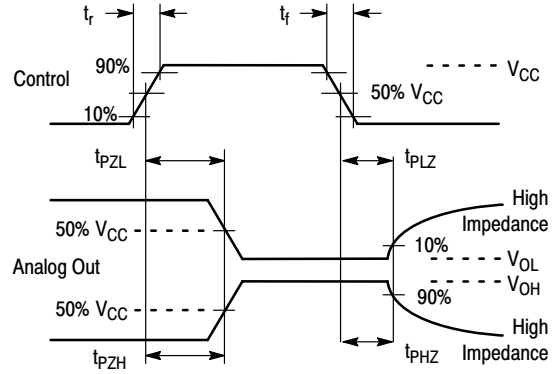

Figure 15. Propagation Delay, ON/OFF Control

DEVICE ORDERING INFORMATION

Device Order Number	Device Nomenclature						Package Type	Tape and Reel Size
	Circuit Indicator	Temp Range Identifier	Technology	Device Function	Package Suffix	Tape & Reel Suffix		
MC74VHC1G66DFT1	MC	74	VHC1G	66	DF	T1	SC70-5/ SC-88A/ SOT-353	178 mm (7") 3000 Unit
MC74VHC1G66DFT2	MC	74	VHC1G	66	DF	T2	SC70-5/ SC-88A/ SOT-353	178 mm (7") 3000 Unit
MC74VHC1G66DTT1	MC	74	VHC1G	66	DT	T1	SOT23-5/ TSOP-5/ SC59-5	178 mm (7") 3000 Unit

MC74VHC1G66

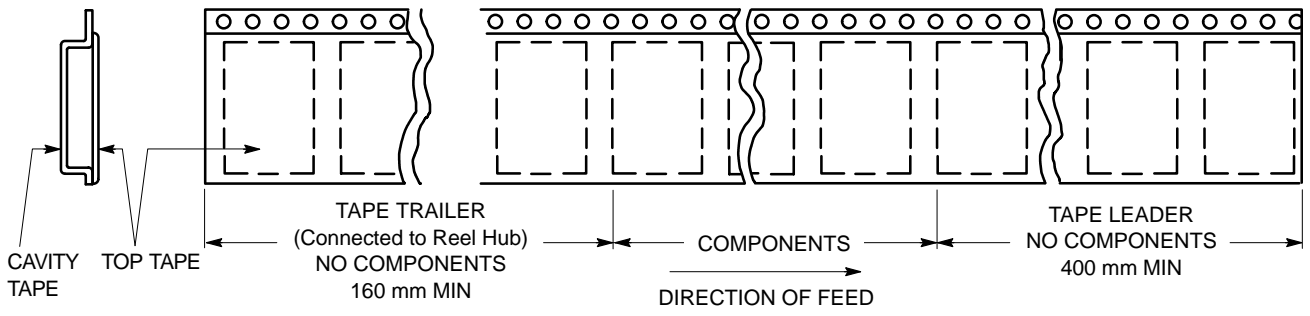

Figure 16. Tape Ends for Finished Goods

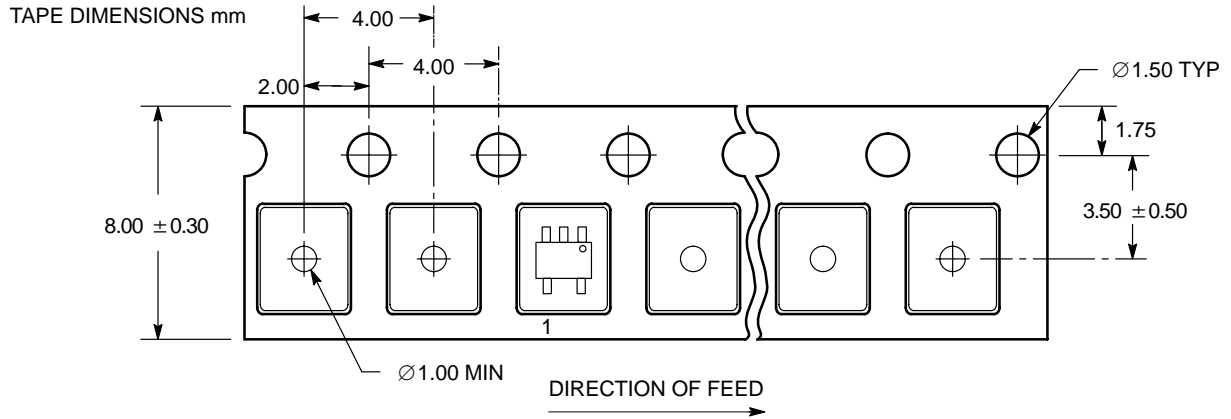

Figure 17. SC-70-5/SC-88A/SOT-353 DFT1 Reel Configuration/Orientation

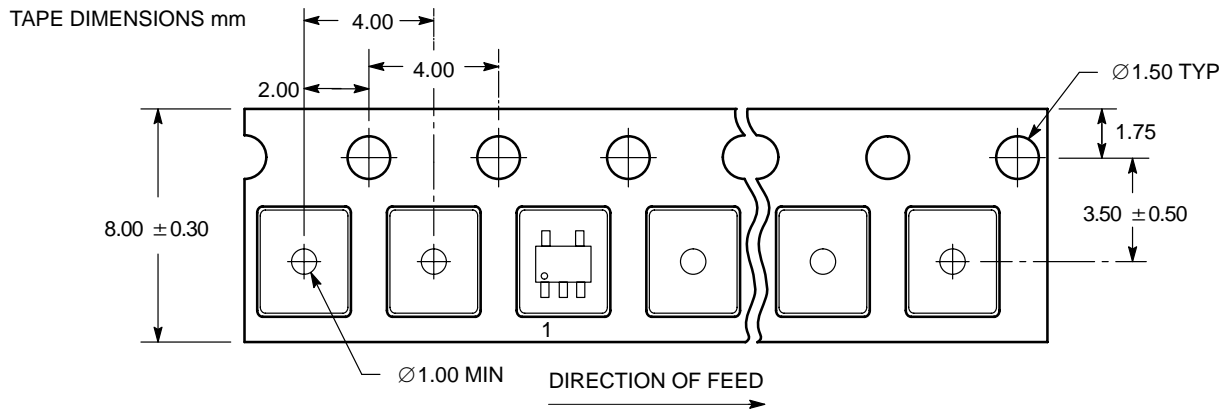

Figure 18. SC-70/SC-88A/SOT-353 DFT2 and SOT23-5/TSOP-5/SC59-5 DTT1 Reel Configuration/Orientation

MC74VHC1G66

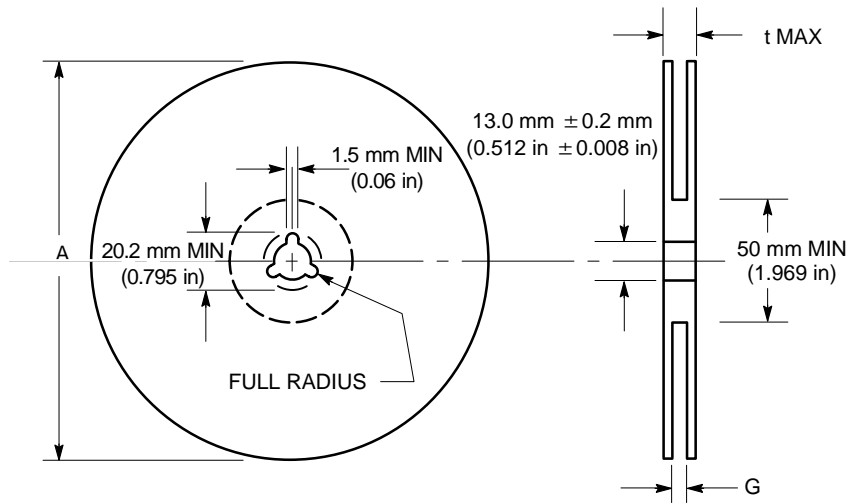

Figure 19. Reel Dimensions

REEL DIMENSIONS

Tape Size	T and R Suffix	A Max	G	t Max
8 mm	T1, T2	178 mm (7 in)	8.4 mm, + 1.5 mm, -0.0 (0.33 in + 0.059 in, -0.00)	14.4 mm (0.56 in)

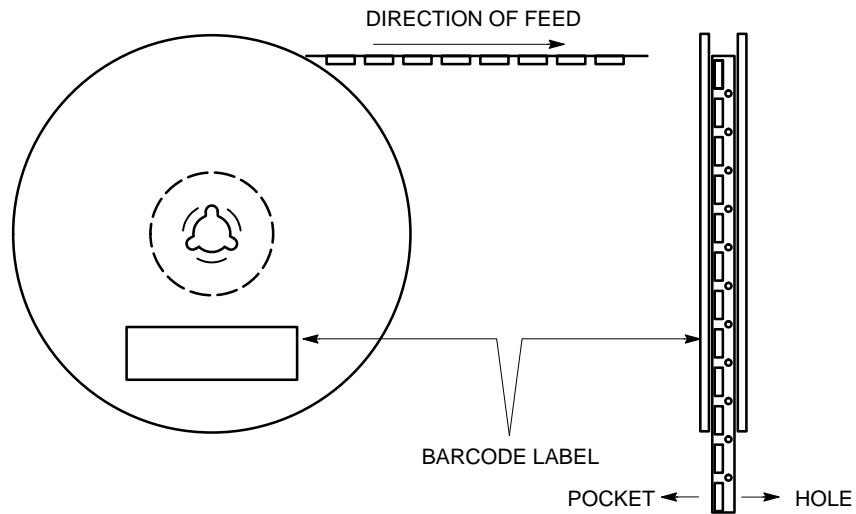
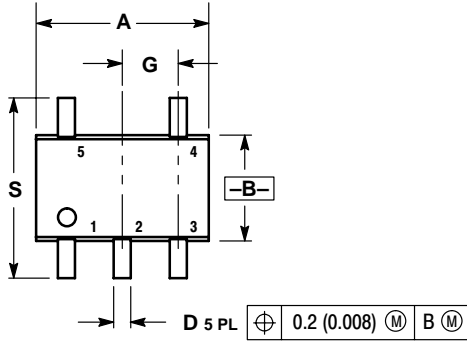

Figure 20. Reel Winding Direction

MC74VHC1G66

PACKAGE DIMENSIONS

SC70-5/SC-88A/SOT-353
 DF SUFFIX
 5-LEAD PACKAGE
 CASE 419A-02
 ISSUE F



NOTES:

1. DIMENSIONING AND TOLERANCING PER ANSI Y14.5M, 1982.
2. CONTROLLING DIMENSION: INCH.
3. 419A-01 OBSOLETE. NEW STANDARD 419A-02.

DIM	INCHES		MILLIMETERS	
	MIN	MAX	MIN	MAX
A	0.071	0.087	1.80	2.20
B	0.045	0.053	1.15	1.35
C	0.031	0.043	0.80	1.10
D	0.004	0.012	0.10	0.30
G	0.026 BSC		0.65 BSC	
H	---	0.004	---	0.10
J	0.004	0.010	0.10	0.25
K	0.004	0.012	0.10	0.30
N	0.008 REF		0.20 REF	
S	0.079	0.087	2.00	2.20

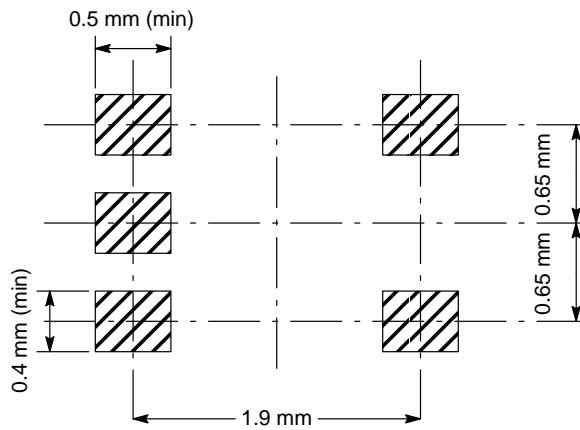
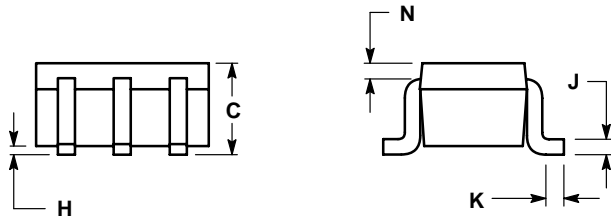

MC74VHC1G66

PACKAGE DIMENSIONS

SOT23-5/TSOP-5/SC59-5

DT SUFFIX

5-LEAD PACKAGE

CASE 483-01

ISSUE B

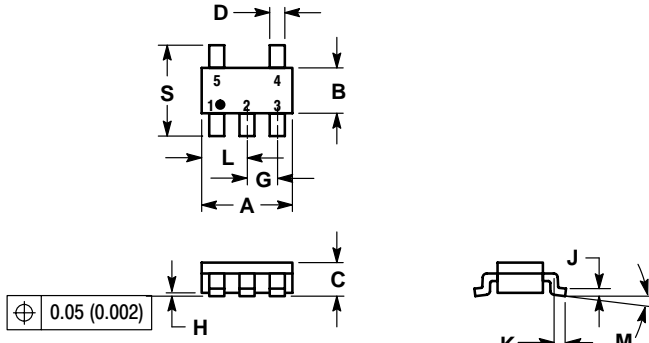

NOTES:

1. DIMENSIONING AND TOLERANCING PER ANSI Y14.5M, 1982.
2. CONTROLLING DIMENSION: MILLIMETER.
3. MAXIMUM LEAD THICKNESS INCLUDES LEAD FINISH THICKNESS. MINIMUM LEAD THICKNESS IS THE MINIMUM THICKNESS OF BASE MATERIAL.

DIM	MILLIMETERS		INCHES	
	MIN	MAX	MIN	MAX
A	2.90	3.10	0.1142	0.1220
B	1.30	1.70	0.0512	0.0669
C	0.90	1.10	0.0354	0.0433
D	0.25	0.50	0.0098	0.0197
G	0.85	1.05	0.0335	0.0413
H	0.013	0.100	0.0005	0.0040
J	0.10	0.26	0.0040	0.0102
K	0.20	0.60	0.0079	0.0236
L	1.25	1.55	0.0493	0.0610
M	0°	10°	0°	10°
S	2.50	3.00	0.0985	0.1181

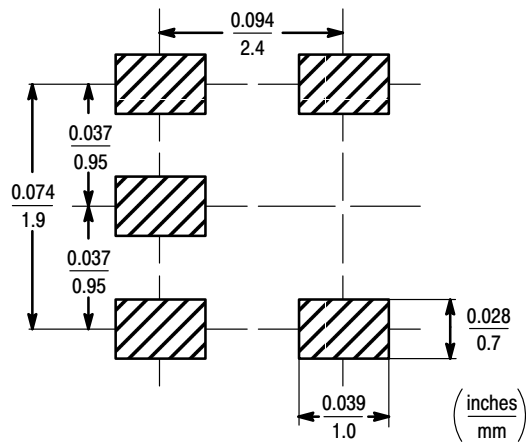

Notes

MC74VHC1G66

ON Semiconductor and  are registered trademarks of Semiconductor Components Industries, LLC (SCILLC). SCILLC reserves the right to make changes without further notice to any products herein. SCILLC makes no warranty, representation or guarantee regarding the suitability of its products for any particular purpose, nor does SCILLC assume any liability arising out of the application or use of any product or circuit, and specifically disclaims any and all liability, including without limitation special, consequential or incidental damages. "Typical" parameters which may be provided in SCILLC data sheets and/or specifications can and do vary in different applications and actual performance may vary over time. All operating parameters, including "Typicals" must be validated for each customer application by customer's technical experts. SCILLC does not convey any license under its patent rights nor the rights of others. SCILLC products are not designed, intended, or authorized for use as components in systems intended for surgical implant into the body, or other applications intended to support or sustain life, or for any other application in which the failure of the SCILLC product could create a situation where personal injury or death may occur. Should Buyer purchase or use SCILLC products for any such unintended or unauthorized application, Buyer shall indemnify and hold SCILLC and its officers, employees, subsidiaries, affiliates, and distributors harmless against all claims, costs, damages, and expenses, and reasonable attorney fees arising out of, directly or indirectly, any claim of personal injury or death associated with such unintended or unauthorized use, even if such claim alleges that SCILLC was negligent regarding the design or manufacture of the part. SCILLC is an Equal Opportunity/Affirmative Action Employer.

PUBLICATION ORDERING INFORMATION

Literature Fulfillment:

Literature Distribution Center for ON Semiconductor
P.O. Box 5163, Denver, Colorado 80217 USA
Phone: 303-675-2175 or 800-344-3860 Toll Free USA/Canada
Fax: 303-675-2176 or 800-344-3867 Toll Free USA/Canada
Email: ONlit@hibbertco.com

N. American Technical Support: 800-282-9855 Toll Free USA/Canada

JAPAN: ON Semiconductor, Japan Customer Focus Center
4-32-1 Nishi-Gotanda, Shinagawa-ku, Tokyo, Japan 141-0031
Phone: 81-3-5740-2700
Email: r14525@onsemi.com

ON Semiconductor Website: <http://onsemi.com>

For additional information, please contact your local Sales Representative.