



M68AF511A

4 Mbit (512K x8), 5V Asynchronous SRAM

FEATURES SUMMARY

- SUPPLY VOLTAGE: 4.5 to 5.5V
- 512K x 8 bits SRAM with OUTPUT ENABLE
- EQUAL CYCLE and ACCESS TIMES: 55ns
- LOW STANDBY CURRENT
- LOW V_{CC} DATA RETENTION: 2V
- TRI-STATE COMMON I/O
- LOW ACTIVE and STANDBY POWER

Figure 1. Packages

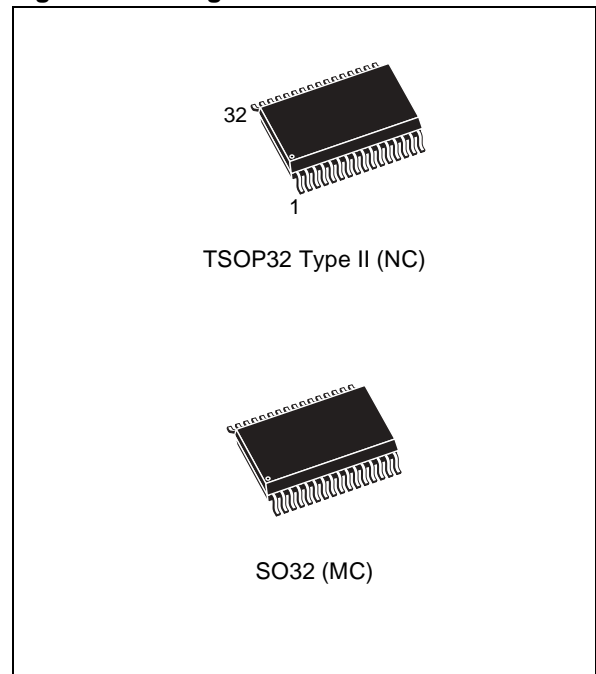

TABLE OF CONTENTS

FEATURES SUMMARY	1
Figure 1. Packages	1
SUMMARY DESCRIPTION	4
Figure 2. Logic Diagram	4
Figure 3. TSOP and SO Connections	5
Figure 4. Block Diagram	6
OPERATION	7
Read Mode	7
Write Mode	7
Table 2. Operating Modes	7
MAXIMUM RATING	8
Table 3. Absolute Maximum Ratings	8
DC AND AC PARAMETERS	9
Table 4. Operating and AC Measurement Conditions	9
Figure 5. AC Measurement I/O Waveform	9
Figure 6. AC Measurement Load Circuit	9
Table 5. Capacitance	10
Table 6. DC Characteristics	10
Figure 7. Address Controlled, Read Mode AC Waveforms	11
Figure 8. Chip Enable or Output Enable Controlled, Read Mode AC Waveforms	11
Figure 9. Chip Enable Controlled, Standby Mode AC Waveforms	12
Table 7. Read and Standby Mode AC Characteristics	13
Figure 10. Write Enable Controlled, Write AC Waveforms	14
Figure 11. Chip Enable Controlled, Write AC Waveforms	14
Table 8. Write Mode AC Characteristics	15
Figure 12. Low V_{CC} Data Retention AC Waveforms	16
Table 9. Low V_{CC} Data Retention Characteristics	16
PACKAGE MECHANICAL	17
Figure 13. TSOP 32 Type II - 32 lead Plastic Thin Small Outline Type II, Package Outline	17
Table 10. TSOP 32 Type II - 32 lead Plastic Thin Small Outline Type II, Package Mechanical Data	17
Figure 14. SO32 - 32 lead Plastic Small Outline, Package Outline	18
Table 11. SO32 - 32 lead Plastic Small Outline, Package Mechanical Data	18
PART NUMBERING	19
Table 12. Ordering Information Scheme	19

REVISION HISTORY 20
Table 13.Document Revision History 20

SUMMARY DESCRIPTION

The M68AF511A is a 4 Mbit (4,194,304 bit) CMOS SRAM, organized as 524,288 words by 8 bits. The device features fully static operation requiring no external clocks or timing strobes, with equal address access and cycle times. It requires a single 4.5 to 5.5V supply.

This device has an automatic power-down feature, reducing the power consumption by over 99% when deselected.

The M68AF511A is available in a 32 lead TSOP Type II and 32 lead SO packages.

Figure 2. Logic Diagram

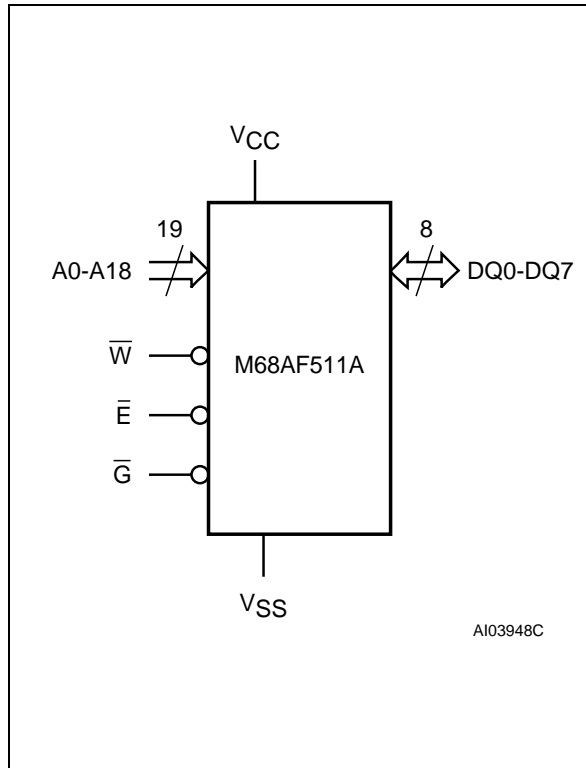

Table 1. Signal Names

A0-A18	Address Inputs
DQ0-DQ7	Data Input/Output
\bar{E}	Chip Enable
\bar{G}	Output Enable
\bar{W}	Write Enable
VCC	Supply Voltage
VSS	Ground

Figure 3. TSOP and SO Connections

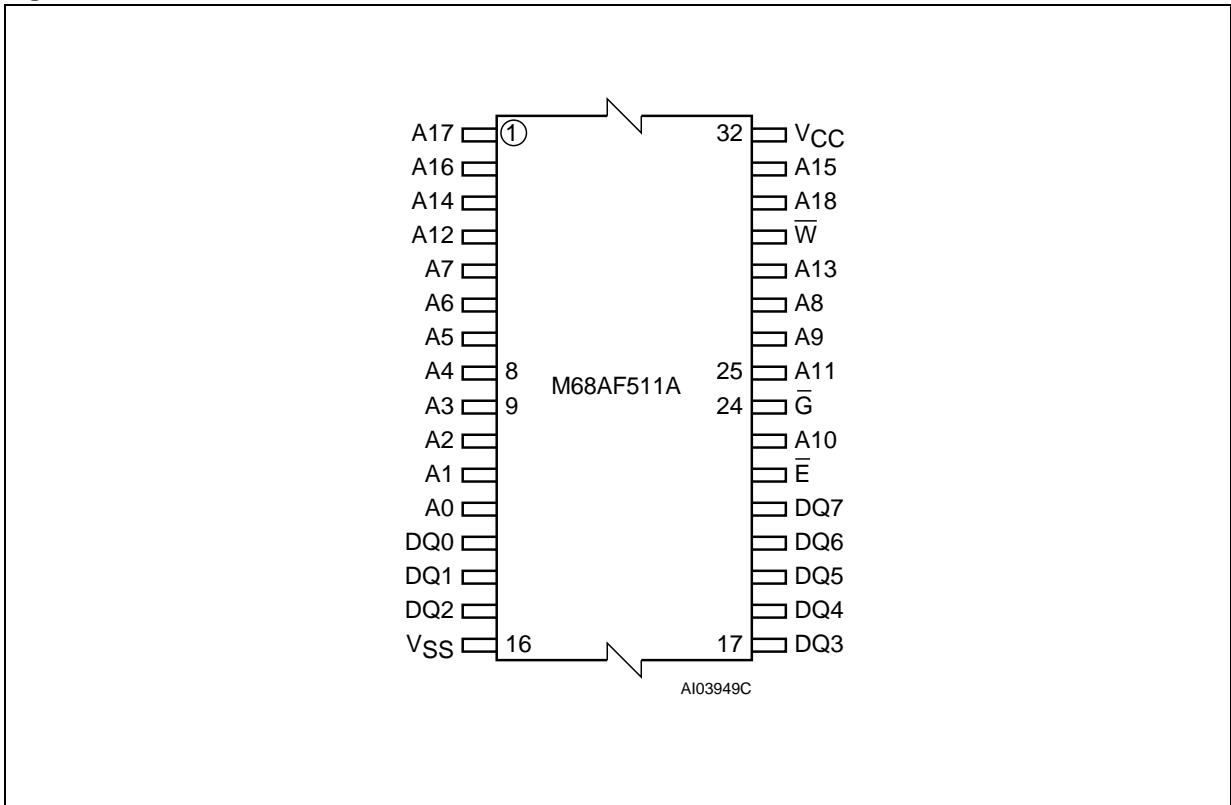
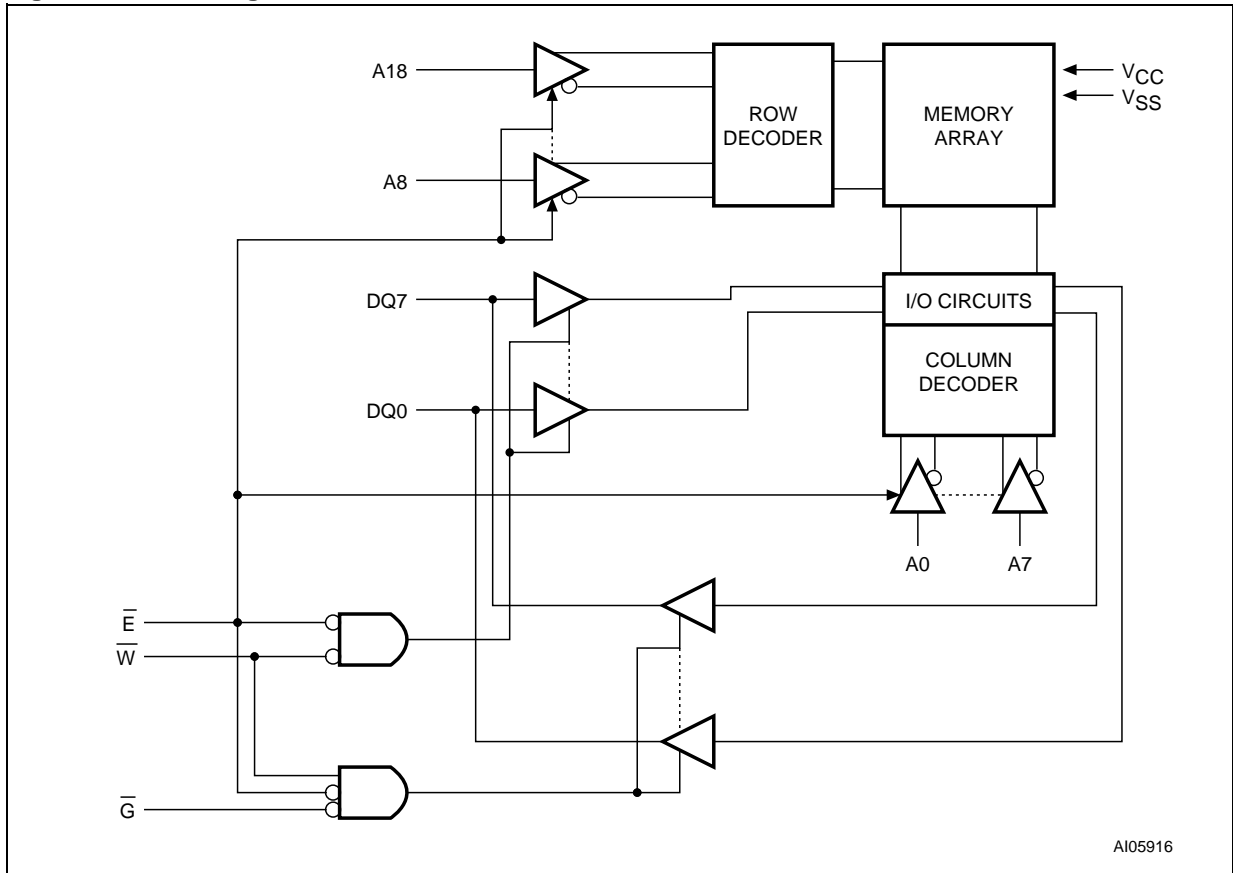

Figure 4. Block Diagram



OPERATION

The M68AF511A has a Chip Enable power down feature which invokes an automatic standby mode whenever Chip Enable is de-asserted (\bar{E} = High). An Output Enable (\bar{G}) signal provides a high speed tri-state control, allowing fast read/write cy-

cles to be achieved with the common I/O data bus. Operational modes are determined by device control inputs \bar{W} and \bar{E} as summarized in the Operating Modes table (Table 2).

Read Mode

The M68AF511A is in the Read mode whenever Write Enable (\bar{W}) is High with Output Enable (\bar{G}) Low, and Chip Enable (\bar{E}) is asserted. This provides access to data from eight of the 4,194,304 locations in the static memory array, specified by the 19 address inputs. Valid data will be available at the eight output pins within t_{AVQV} after the last

stable address, providing \bar{G} is Low and \bar{E} is Low. If Chip Enable or Output Enable access times are not met, data access will be measured from the limiting parameter (t_{ELQV} or t_{GLQV}) rather than the address. Data out may be indeterminate at t_{ELQX} and t_{GLQX} , but data lines will always be valid at t_{AVQV} .

Write Mode

The M68AF511A is in the Write mode whenever the \bar{W} and \bar{E} pins are Low. Either the Chip Enable input (\bar{E}) or the Write Enable input (\bar{W}) must be de-asserted during Address transitions for subsequent write cycles. Write begins with the concurrence of Chip Enable being active with \bar{W} low. Therefore, address setup time is referenced to Write Enable and Chip Enable as t_{AVWL} and t_{AVEH} respectively, and is determined by the latter occurring edge.

The Write cycle can be terminated by the earlier rising edge of \bar{E} , or \bar{W} . If the Output is enabled (\bar{E} = Low and \bar{G} = Low), then \bar{W} will return the outputs to high impedance within t_{WLQZ} of its falling edge. Care must be taken to avoid bus contention in this type of operation. Data input must be valid for t_{DVWH} before the rising edge of Write Enable, or for t_{DVEH} before the rising edge of \bar{E} , whichever occurs first, and remain valid for t_{WHDX} or t_{EHDX} .

Table 2. Operating Modes

Operation	\bar{E}	\bar{W}	\bar{G}	DQ0-DQ7	Power
Output disabled	V_{IL}	X	V_{IH}	Hi-Z	Active (I_{CC})
Read	V_{IL}	V_{IH}	V_{IL}	Data Output	Active (I_{CC})
Write	V_{IL}	V_{IL}	X	Data Input	Active (I_{CC})
Deselect	V_{IH}	X	X	Hi-Z	Standby (I_{SB})

Note: X = V_{IH} or V_{IL} .

MAXIMUM RATING

Stressing the device above the rating listed in the Absolute Maximum Ratings table may cause permanent damage to the device. These are stress ratings only and operation of the device at these or any other conditions above those indicated in the Operating sections of this specification is not im-

plied. Exposure to Absolute Maximum Rating conditions for periods greater than 1 sec may affect device reliability. Refer also to the STMicroelectronics SURE Program and other relevant quality documents.

Table 3. Absolute Maximum Ratings

Symbol	Parameter	Value	Unit
$I_O^{(1)}$	Output Current	20	mA
T_A	Ambient Operating Temperature	-55 to 125	°C
T_{STG}	Storage Temperature	-65 to 150	°C
V_{CC}	Supply Voltage	-0.5 to 6.5	V
$V_{IO}^{(2)}$	Input or Output Voltage	-0.5 to $V_{CC} + 0.5$	V
P_D	Power Dissipation	1	W

Note: 1. One output at a time, not to exceed 1 second duration.
2. Up to a maximum operating V_{CC} of 6.0V only.

DC AND AC PARAMETERS

This section summarizes the operating and measurement conditions, as well as the DC and AC characteristics of the device. The parameters in the following DC and AC Characteristic tables are derived from tests performed under the Measure-

ment Conditions listed in the relevant tables. Designers should check that the operating conditions in their projects match the measurement conditions when using the quoted parameters.

Table 4. Operating and AC Measurement Conditions

Parameter		M68AF511A
V _{CC} Supply Voltage		4.5 to 5.5V
Ambient Operating Temperature	Range 1: Commercial	0 to 70°C
	Range 6: Industrial	-40 to 85°C
Load Capacitance (C _L)		100pF
Output Circuit Protection Resistance (R ₁)		3.0kΩ
Load Resistance (R ₂)		3.1kΩ
Input Rise and Fall Times		1ns/V
Input Pulse Voltages		0 to V _{CC}
Input and Output Timing Ref. Voltages		V _{CC} /2
Output Transition Timing Ref. Voltages		V _{RL} = 0.3V _{CC} ; V _{RH} = 0.7V _{CC}

Figure 5. AC Measurement I/O Waveform

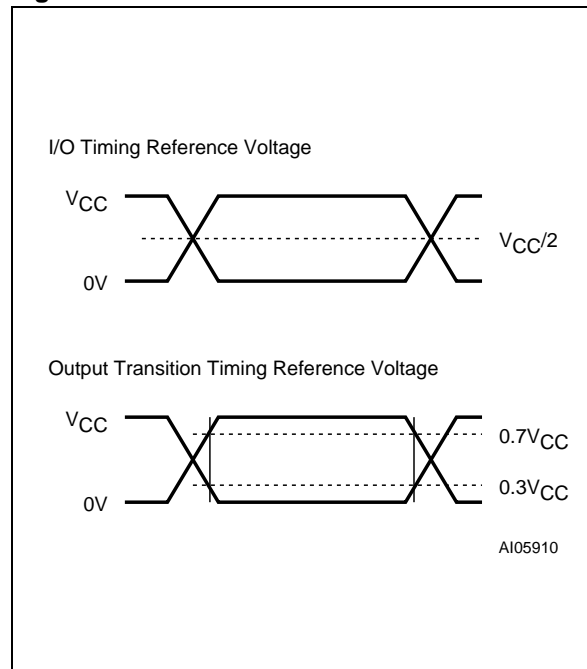

Figure 6. AC Measurement Load Circuit

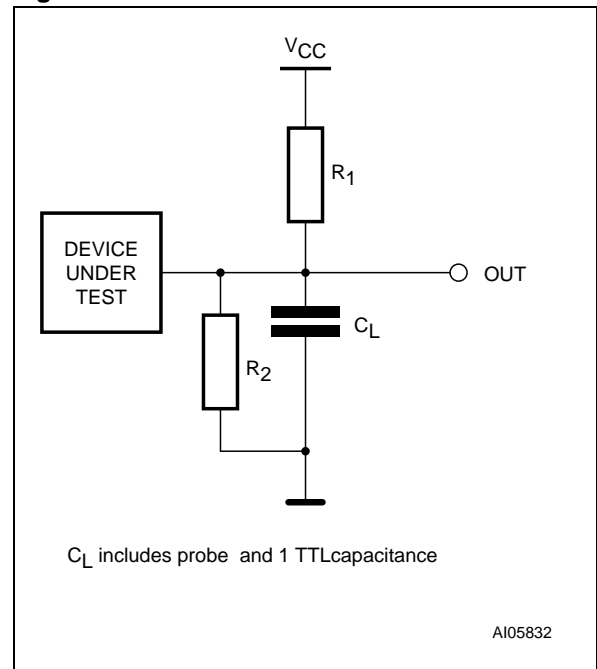

Table 5. Capacitance

Symbol	Parameter (1,2)	Test Condition	Min	Max	Unit
C _{IN}	Input Capacitance on all pins (except DQ)	V _{IN} = 0V		6	pF
C _{OUT}	Output Capacitance	V _{OUT} = 0V		8	pF

Note: 1. Sampled only, not 100% tested.
2. At T_A = 25°C, f = 1MHz, V_{CC} = 5.0V.

Table 6. DC Characteristics

Symbol	Parameter	Test Condition	Min	Typ	Max	Unit
I _{CC1} (1,2)	Operating Supply Current	V _{CC} = 5.5V, f = 1/t _{AVAV} , I _{OUT} = 0mA			55	mA
I _{CC2} (3)	Operating Supply Current	V _{CC} = 5.5V, f = 1MHz, I _{OUT} = 0mA			5	mA
I _{LI}	Input Leakage Current	0V ≤ V _{IN} ≤ V _{CC}	-1		1	μA
I _{LO} (4)	Output Leakage Current	0V ≤ V _{OUT} ≤ V _{CC}	-1		1	μA
I _{SB}	Standby Supply Current CMOS	V _{CC} = 5.5V, $\bar{E} \geq V_{CC} - 0.2V$, f = 0		5	10	μA
V _{IH}	Input High Voltage		2.2		V _{CC} + 0.3	V
V _{IL}	Input Low Voltage		-0.3		0.8	V
V _{OH}	Output High Voltage	I _{OH} = -1.0mA	2.4			V
V _{OL}	Output Low Voltage	I _{OL} = 2.1mA			0.4	V

Note: 1. Average AC current, cycling at t_{AVAV} minimum.
2. \bar{E} = V_{IL}, V_{IN} = V_{IH} or V_{IL}.
3. $\bar{E} \leq 0.2V$, V_{IN} ≤ 0.2V or V_{IN} ≥ V_{CC} - 0.2V.
4. Output disable.

Figure 7. Address Controlled, Read Mode AC Waveforms

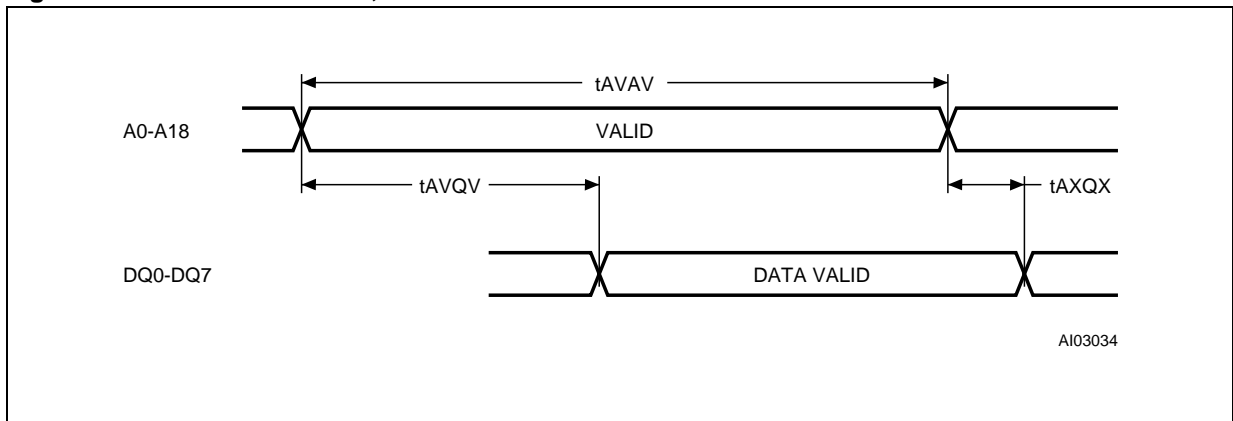

Note: \bar{E} = Low, \bar{G} = Low, \bar{W} = High.

Figure 8. Chip Enable or Output Enable Controlled, Read Mode AC Waveforms

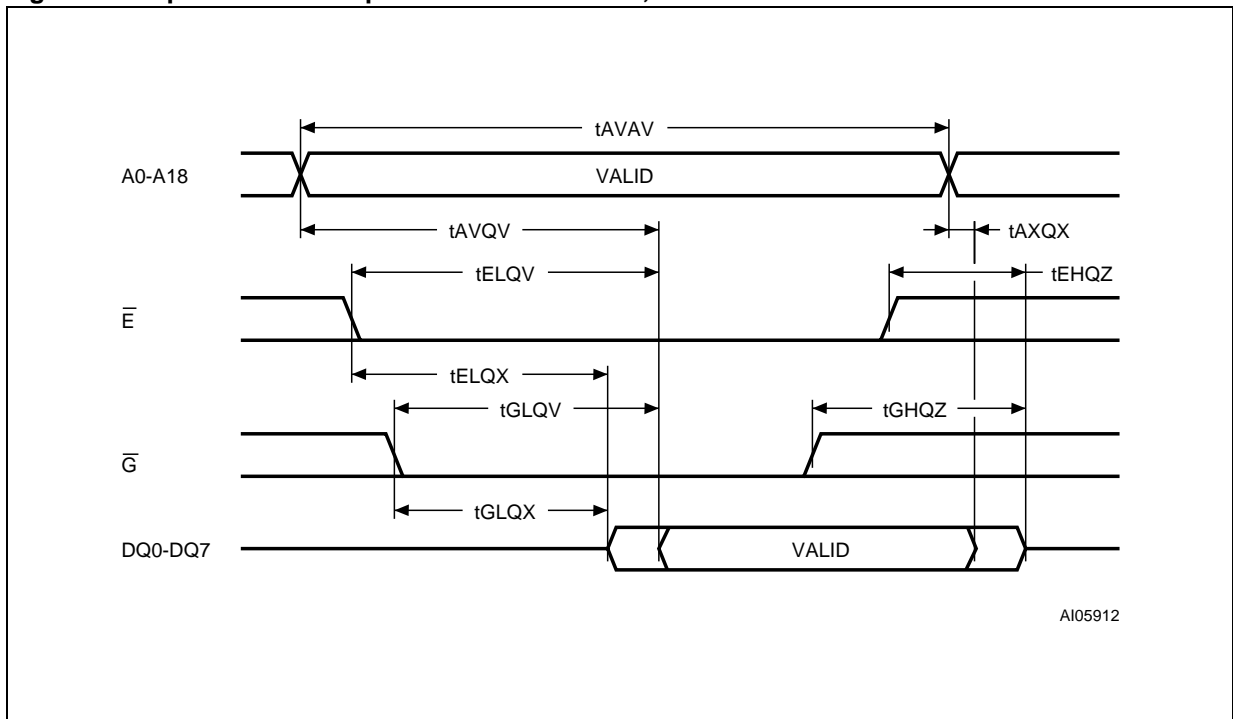

Note: Write Enable (\bar{W}) = High.

Figure 9. Chip Enable Controlled, Standby Mode AC Waveforms

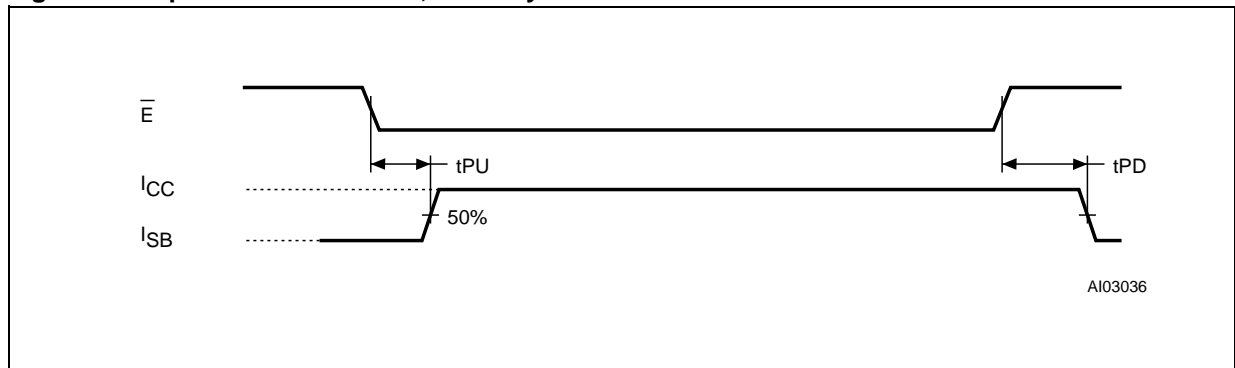

Table 7. Read and Standby Mode AC Characteristics

Symbol	Parameter	M68AF511A			Unit
			55	70	
t_{AVAV}	Read Cycle Time	Min	55	70	ns
t_{AVQV}	Address Valid to Output Valid	Max	55	70	ns
$t_{AXQX}^{(1)}$	Data hold from Address change	Min	5	5	ns
$t_{EHQZ}^{(2,3)}$	Chip Enable High to Output Hi-Z	Max	20	25	ns
t_{ELQV}	Chip Enable Low to Output Valid	Max	55	70	ns
$t_{ELQX}^{(1)}$	Chip Enable Low to Output Transition	Min	5	5	ns
$t_{GHQZ}^{(2,3)}$	Output Enable High to Output Hi-Z	Max	20	25	ns
t_{GLQV}	Output Enable Low to Output Valid	Max	25	35	ns
$t_{GLQX}^{(1)}$	Output Enable Low to Output Transition	Min	5	5	ns
t_{PD}	Chip Enable High to Power Down	Max	55	70	ns
t_{PU}	Chip Enable Low to Power Up	Min	0	0	ns

Note: 1. Test conditions assume transition timing reference level = $0.3V_{CC}$ or $0.7V_{CC}$.

2. At any given temperature and voltage condition, t_{EHQZ} is less than t_{ELQX} and t_{GHQZ} is less than t_{GLQX} for any given device.

3. These parameters are defined as the time at which the outputs achieve the open circuit conditions and are not referenced to output voltage levels.

Figure 10. Write Enable Controlled, Write AC Waveforms

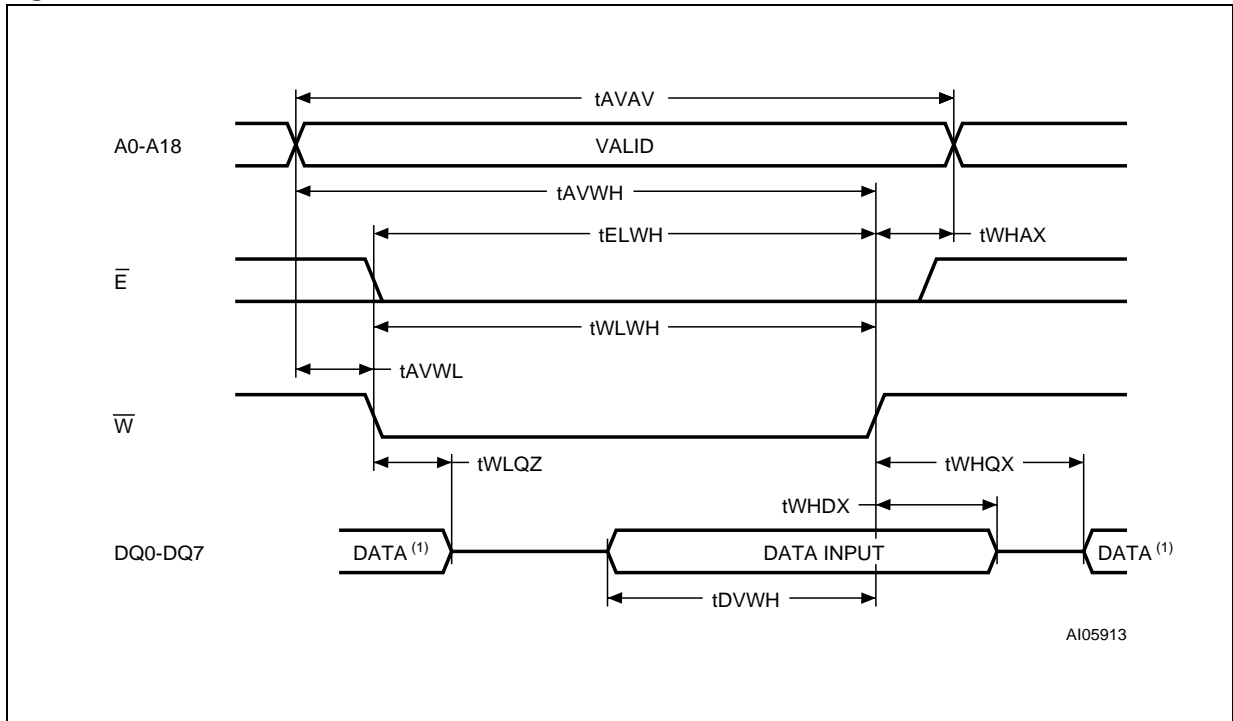

Note: 1. During this period DQ0-DQ7 are in output state and input signal should not be applied.

Figure 11. Chip Enable Controlled, Write AC Waveforms

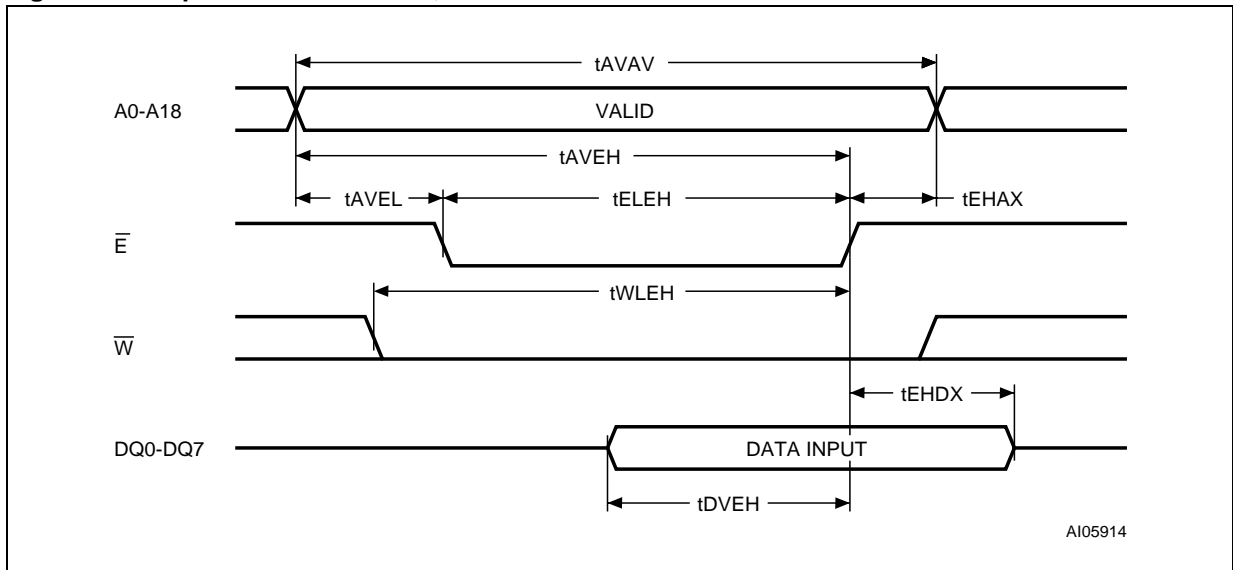

Table 8. Write Mode AC Characteristics

Symbol	Parameter	M68AF511A			Unit
			55	70	
t _{AVAV}	Write Cycle Time	Min	55	70	ns
t _{AVEH}	Address Valid to Chip Enable High	Min	45	60	ns
t _{AVEL}	Address Valid to Chip Enable Low	Min	0	0	ns
t _{AVWH}	Address Valid to Write Enable High	Min	45	60	ns
t _{AVWL}	Address Valid to Write Enable Low	Min	0	0	ns
t _{DVEH}	Input Valid to Chip Enable High	Min	25	30	ns
t _{DVWH}	Input Valid to Write Enable High	Min	25	30	ns
t _{EHAX}	Chip Enable High to Address Transition	Min	0	0	ns
t _{EHDX}	Chip Enable High to Input Transition	Min	0	0	ns
t _{ELEH}	Chip Enable Low to Chip Enable High	Min	45	60	ns
t _{ELWH}	Chip Enable Low to Write Enable High	Min	45	60	ns
t _{WHAX}	Write Enable High to Address Transition	Min	0	0	ns
t _{WHDX}	Write Enable High to Input Transition	Min	0	0	ns
t _{WHQX} ⁽¹⁾	Write Enable High to Output Transition	Min	5	5	ns
t _{WLEH}	Write Enable Low to Chip Enable High	Min	45	60	ns
t _{WLQZ} ^(1,2)	Write Enable Low to Output Hi-Z	Max	20	25	ns
t _{WLWH}	Write Enable Low to Write Enable High	Min	45	60	ns

Note: 1. These parameters are defined as the time at which the outputs achieve the open circuit conditions and are not referenced to output voltage levels.

2. At any given temperature and voltage condition, t_{WLQZ} is less than t_{WHQX} for any given device.

Figure 12. Low V_{CC} Data Retention AC Waveforms

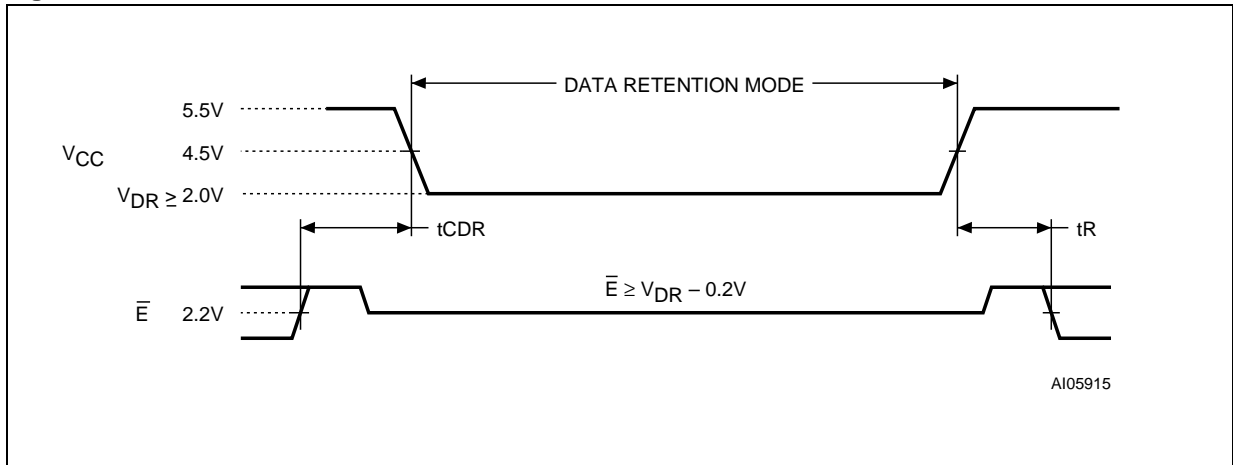

Table 9. Low V_{CC} Data Retention Characteristics

Symbol	Parameter	Test Condition	Min	Typ	Max	Unit
I _{CCDR} ⁽¹⁾	Supply Current (Data Retention)	V _{CC} = 2V, $\bar{E} \geq V_{CC} - 0.2V$, f = 0 ⁽³⁾		4.5	9	μA
t _{CDR} ^(1,2)	Chip Deselected to Data Retention Time		0			ns
t _R ⁽²⁾	Operation Recovery Time		t _{AVAV}			ns
V _{DR} ⁽²⁾	Supply Voltage (Data Retention)	$\bar{E} \geq V_{CC} - 0.2V$, f = 0	2			V

Note: 1. All other Inputs at V_{IH} ≥ V_{CC} - 0.2V or V_{IL} ≤ 0.2V.

2. Tested initially and after any design or process that may affect these parameters. t_{AVAV} is Read cycle time. No input may exceed V_{CC} + 0.2V.

PACKAGE MECHANICAL

Figure 13. TSOP 32 Type II - 32 lead Plastic Thin Small Outline Type II, Package Outline

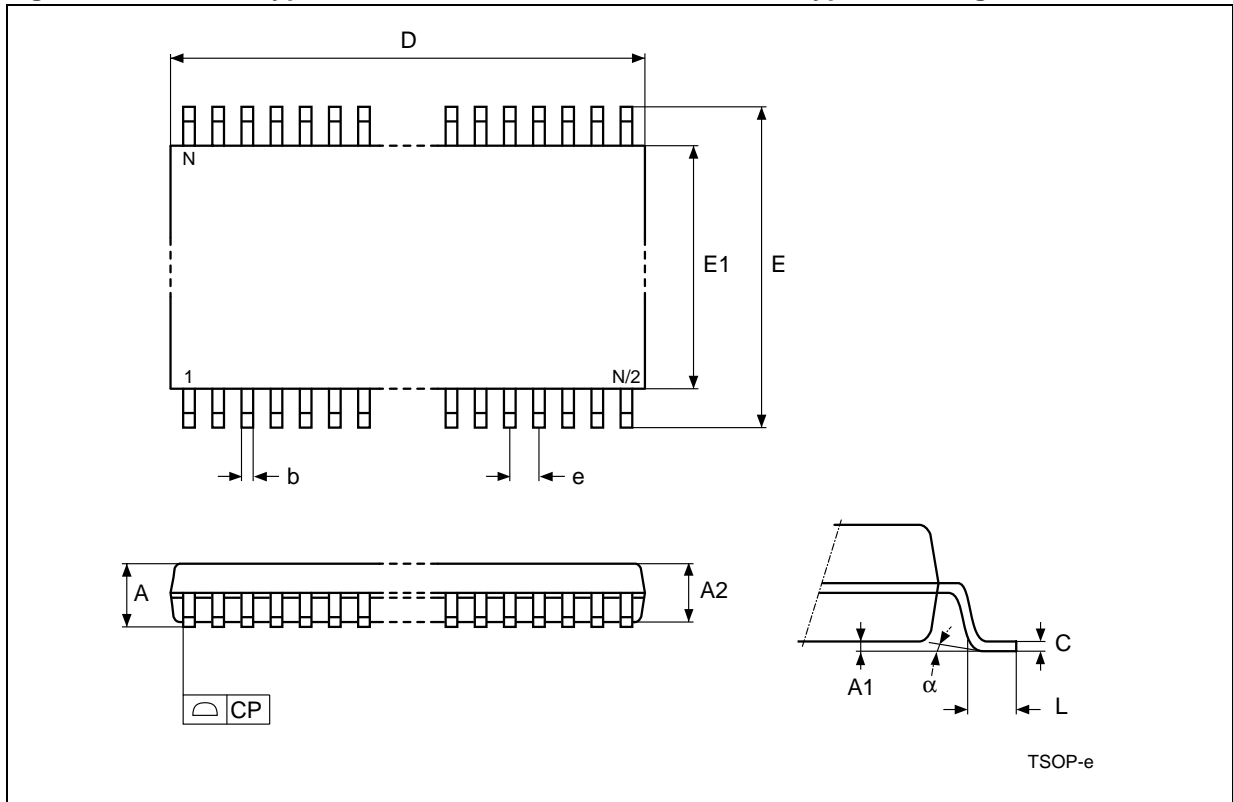

Note: Drawing is not to scale.

Table 10. TSOP 32 Type II - 32 lead Plastic Thin Small Outline Type II, Package Mechanical Data

Symbol	millimeters			inches		
	Typ	Min	Max	Typ	Min	Max
A			1.20			0.047
A1		0.05	0.15		0.002	0.006
A2		0.95	1.05		0.037	0.041
b		0.30	0.52		0.012	0.020
C		0.12	0.21		0.005	0.008
CP			0.10			0.004
D		20.82	21.08		0.820	0.830
e	1.27	–	–	0.050	–	–
E		11.56	11.96		0.455	0.471
E1		10.03	10.29		0.395	0.405
L		0.40	0.60		0.016	0.024
α		0°	5°		0°	5°
N		32			32	

Figure 14. SO32 - 32 lead Plastic Small Outline, Package Outline

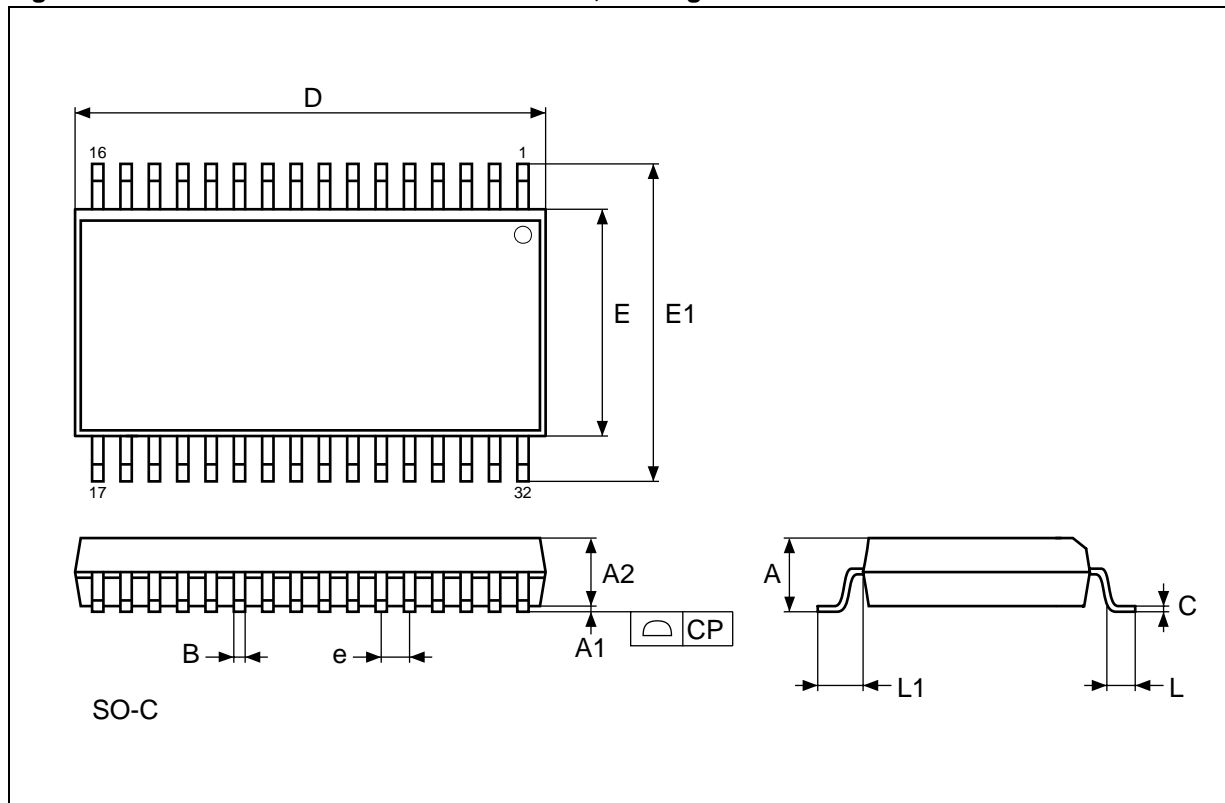

Note: Drawing is not to scale.

Table 11. SO32 - 32 lead Plastic Small Outline, Package Mechanical Data

Symbol	millimeters			inches		
	Typ	Min	Max	Typ	Min	Max
A			3.00			0.118
A1		0.10			0.004	
A2		2.57	2.82		0.101	0.111
B		0.36	0.51		0.014	0.020
C		0.15	0.30		0.006	0.012
D		20.14	20.75		0.793	0.817
E		11.18	11.43		0.440	0.450
E1		13.87	14.38		0.546	0.566
e	1.27	-	-	0.050	-	-
L		0.58	0.99		0.023	0.039
L1		1.19	1.60		0.047	0.063
CP			0.10			0.004

PART NUMBERING

Table 12. Ordering Information Scheme

Example:	M	68	A	F	5	1	1	A	L	55	NC	1	T
Device Type	M	68											
M68													
Mode			A										
A = Asynchronous													
Operating Voltage				F									
F = 4.5 to 5.5V													
Array Organization					5	1							
511 = 4 Mbit (512K x8)													
Option 1							A						
A = 1 Chip Enable													
Option 2								L					
L = L-Die M = M-Die													
Speed Class										55			
55 = 55ns 70 = 70ns													
Package											NC		
NC = TSOP32 Type II MC = SO32													
Operative Temperature												1	
1 = 0 to 70°C 6 = -40 to 85°C													
Shipping													T
T = Tape & Reel Packing													

For a list of available options (Speed, Package, etc....) or for further information on any aspect of this device, please contact the STMicroelectronics Sales Office nearest to you.

REVISION HISTORY

Table 13. Document Revision History

Date	Version	Revision Details
July 2001	-01	First Issue
08-Aug-2001	-02	SO32 Package added 55ns Speed class introduced Industrial Temperature Range added (Range 6)
27-Sep-2001	-03	Typing error, Table 5, Note 2
18-Oct-2001	-04	SO32 Package Mechanical and Data added
29-Nov-2001	-05	Note Removed from Ordering Information Scheme
08-Jan-2002	-06	PDIP32 package added Document fully revised
08-Feb-2002	-07	t_{ELQX} , t_{AXQX} changed in Read and Standby Mode AC Characteristics Table (Table 7) t_{DVEH} , t_{DVWH} , t_{WLWH} changed in Write Mode AC Characteristics Table (Table 12)
25-Feb-2002	-08	PDIP32 package removed Block Diagram clarified (Figure 4) Absolute Maximum Ratings table clarified (Table 3) Operating and AC Measurement Conditions table and figure clarified (Table 4, Figure 6) DC Characteristics table clarified (Table 6) Read and Standby Mode AC Characteristics table clarified (Table 7) Write Mode AC Characteristics table clarified (Table 12)
03-Mar-2002	-09	Operating and AC Measurement Conditions table clarified (Table 4) I_{CCDR} Test Condition clarified (Table 9)
25-Mar-2002	-10	Read and Standby Mode AC Characteristics clarified (Table 7) Low V_{CC} Data Retention Characteristics clarified (Table 9)
18-Apr-2002	-11	Read and Standby Mode AC Characteristics (Table 7): t_{PD} and t_{PU} clarified
26-Apr-2002	-12	DC Characteristics Table clarified (Table 6) Write Mode AC Characteristics Table clarified (Table 12)
17-May-2002	-13	I_{SB} and I_{CCDR} values clarified
02-Oct-2002	13.1	Revision numbering modified: a minor revision will be indicated by incrementing the digit after the dot, and a major revision, by incrementing the digit before the dot (revision version 013 equals 13.0). New part number added.
09-Oct-2002	13.2	Datasheet number simplified.
24-Sep-2004	14	Document structure modified: – Chapter OPERATION moved before chapter MAXIMUM RATING. – AC Characteristics Tables and waveforms moved to the DC/AC PARAMETERS section. t_{PU} and t_{PD} updated in Table 7.

Information furnished is believed to be accurate and reliable. However, STMicroelectronics assumes no responsibility for the consequences of use of such information nor for any infringement of patents or other rights of third parties which may result from its use. No license is granted by implication or otherwise under any patent or patent rights of STMicroelectronics. Specifications mentioned in this publication are subject to change without notice. This publication supersedes and replaces all information previously supplied. STMicroelectronics products are not authorized for use as critical components in life support devices or systems without express written approval of STMicroelectronics.

The ST logo is a registered trademark of STMicroelectronics.

All other names are the property of their respective owners

© 2004 STMicroelectronics - All rights reserved

STMicroelectronics group of companies

Australia - Belgium - Brazil - Canada - China - Czech Republic - Finland - France - Germany - Hong Kong - India - Israel - Italy - Japan -
Malaysia - Malta - Morocco - Singapore - Spain - Sweden - Switzerland - United Kingdom - United States of America

www.st.com