



SANYO Semiconductors

# DATA SHEET

## LV8048CS — Bi-CMOS IC For Digital Still Cameras Single-chip motor driver IC for

### Overview

LV8048CS is single-chip motor driver IC for digital still cameras.

### Features

- The actuator driver for DSC is built into single-chip.
- Two 256-division microstep output channel, and two constant current output channels
- All actuators can be driven at the same time
- AF / ZOOM stepping motor is driven by the clock signal
- Supports PWM control of a DC zoom motor
- The constant current output reference voltage can be set to one of 16 internal reference voltage levels (motor holding current switching possible).
- Two photosensor drive transistor channels
- Two Schmitt buffer channels (the presence or absence of hysteresis can be set individually).

### Specifications

**Absolute Maximum Ratings** at Ta = 25°C

Parameter	Symbol	Conditions	Ratings	Unit
Supply voltage 1	V <sub>B</sub> max		6.0	V
Supply voltage 2	V <sub>CC</sub> max		6.0	V
Peak output current t	I <sub>O</sub> peak1	OUT5 to 6, OUT9 to 10 (t ≤ 10ms, ON-duty ≤ 20%)	800	mA
	I <sub>O</sub> peak2	OUT1 to 4, OUT7 to 8, OUT11 to 12 (t ≤ 10ms, ON-duty ≤ 20%)	600	mA
Continuous output current	I <sub>O</sub> max1	OUT5 to 6, OUT9 to 10	600	mA
	I <sub>O</sub> max2	OUT1 to 4, OUT7 to 8, OUT11 to 12	400	mA
	I <sub>O</sub> max3	PI1, PI2	40	mA

Continued on next page.

■ Any and all SANYO Semiconductor Co.,Ltd. products described or contained herein are, with regard to "standard application", intended for the use as general electronics equipment (home appliances, AV equipment, communication device, office equipment, industrial equipment etc.). The products mentioned herein shall not be intended for use for any "special application" (medical equipment whose purpose is to sustain life, aerospace instrument, nuclear control device, burning appliances, transportation machine, traffic signal system, safety equipment etc.) that shall require extremely high level of reliability and can directly threaten human lives in case of failure or malfunction of the product or may cause harm to human bodies, nor shall they grant any guarantee thereof. If you should intend to use our products for applications outside the standard applications of our customer who is considering such use and/or outside the scope of our intended standard applications, please consult with us prior to the intended use. If there is no consultation or inquiry before the intended use, our customer shall be solely responsible for the use.

■ Specifications of any and all SANYO Semiconductor Co.,Ltd. products described or contained herein stipulate the performance, characteristics, and functions of the described products in the independent state, and are not guarantees of the performance, characteristics, and functions of the described products as mounted in the customer's products or equipment. To verify symptoms and states that cannot be evaluated in an independent device, the customer should always evaluate and test devices mounted in the customer's products or equipment.

# LV8048CS

Continued from preceding page.

Parameter	Symbol	Conditions	Ratings	Unit
Allowable power dissipation	Pd max	Mounted on a circuit board*	1100	mW
Operating temperature	Topr		-20 to +85	°C
Storage temperature	Tstg		-55 to +150	°C

\* Specified circuit board : 40×50×0.8mm<sup>3</sup> : glass epoxy four-layer board(2S-2P).

## Recommended Operating Conditions at Ta = 25°C

Parameter	Symbol	Conditions	Ratings	Unit
Supply voltage range 1	V <sub>B</sub>	VB1, VB2 (*1) (*2)	2.7 to 5.5	V
Supply voltage range 2	V <sub>CC</sub>	(*2)	2.7 to 5.5	V
Logic level input voltage	V <sub>IN</sub>		0 to V <sub>CC</sub> +0.3	V
Clock frequency	F <sub>CLK</sub>	CLK1, CLK2/PWM, CLK3/ENA6	to 64	kHz
PWM frequency	F <sub>PWM</sub>	CLK2/PWM	to 100	kHz

(\*1) There are no restrictions on the magnitude relationships between the voltages applied to VB1 and VB2.

(\*2) There are no restrictions on the magnitude relationships between the voltages applied to each V<sub>B</sub> and V<sub>CC</sub>.

## Electrical Characteristics at Ta = 25°C, V<sub>B</sub> = 5V, V<sub>CC</sub> = 3.3V

Parameter	Symbol	Conditions	Ratings			Unit
			min	typ	max	
Quiescent current	I <sub>CCO</sub>	ST = low, BI1, BI2 = low			1	μA
Current drain 1	I <sub>B</sub>	ST = high, BI1, BI2 = low, With no output load		75	150	μA
Current drain 2	I <sub>CC</sub>	ST = high, BI1, BI2 = low, With no output load		2.5	4	mA
V <sub>CC</sub> low-voltage cutoff voltage	V <sub>th</sub> V <sub>CC</sub>		2.1	2.4	2.6	V
Low-voltage hysteresis voltage	V <sub>th</sub> HYS		90	140	190	mV
Thermal shutdown temperature	TSD	Design target value	160	180	200	°C
Thermal hysteresis width	ΔTSD	Design target value	20	40	60	°C
<b>AF/ZOOM Motor Drivers (OUT1-2, OUT3-4, OUT5-6, OUT7-8)</b>						
Output on-resistance 1	Ron1	I <sub>O</sub> = 200mA, High side on-resistance		0.6	0.85	Ω
	Rod1	I <sub>O</sub> = 200mA, Low side on-resistance		0.25	0.4	Ω
Output leakage current 1	I <sub>O</sub> leak1				1	μA
Diode forward voltage 1	V <sub>D</sub> 1	I <sub>D</sub> = -400mA	0.7	0.9	1.2	V
Chopping frequency	Fchop1		293	390	488	kHz
	Fchop2		146	195	244	kHz
	Fchop3		428	570	713	kHz
	Fchop4		214	285	356	kHz
Current setting reference voltage	VSEN00		0.185	0.200	0.215	V
	VSEN01		0.125	0.140	0.155	V
	VSEN10		0.085	0.100	0.115	V
	VSEN11		0.045	0.060	0.075	V
Logic pin input current	I <sub>INL</sub>	V <sub>IN</sub> = 0V (ST, CLK1, CLK2/PWM)			1.0	μA
	I <sub>INH</sub>	V <sub>IN</sub> = 3.3V (ST, CLK1, CLK2/PWM)		33	50	μA
High-level input voltage	V <sub>INH</sub>	ST, CLK1, CLK2/PWM	2.5			V
Low-level input voltage	V <sub>INL</sub>	ST, CLK1, CLK2/PWM			1.0	V
<b>Motor driver for aperture, shutter (OUT9-10, OUT11-12)</b>						
Output on-resistance 2	Ron2	I <sub>O</sub> = 200mA, High side on-resistance		0.6	0.85	Ω
	Rod2	I <sub>O</sub> = 200mA, Low side on-resistance		0.25	0.4	Ω
Output leakage current 2	I <sub>O</sub> leak2				1	μA
Diode forward voltage 2	V <sub>D</sub> 2	I <sub>D</sub> = -400mA	0.7	0.9	1.2	V
Constant current output	I <sub>O</sub>	R <sub>f</sub> = 1Ω, (D3, D4, D5, D6) = (0, 0, 0, 0)	190	200	210	mA

Continued on next page.

# LV8048CS

Continued from preceding page.

Parameter	Symbol	Conditions	Ratings			Unit
			min	typ	max	
Internal current setting reference voltages	V <sub>REF1</sub>	(D3, D4, D5, D6) = (0, 0, 0, 0)	0.190	0.200	0.210	V
	V <sub>REF2</sub>	(D3, D4, D5, D6) = (1, 0, 0, 0)	0.162	0.170	0.179	V
	V <sub>REF3</sub>	(D3, D4, D5, D6) = (0, 1, 0, 0)	0.157	0.165	0.173	V
	V <sub>REF4</sub>	(D3, D4, D5, D6) = (1, 1, 0, 0)	0.152	0.160	0.168	V
	V <sub>REF5</sub>	(D3, D4, D5, D6) = (0, 0, 1, 0)	0.147	0.155	0.163	V
	V <sub>REF6</sub>	(D3, D4, D5, D6) = (1, 0, 1, 0)	0.143	0.150	0.158	V
	V <sub>REF7</sub>	(D3, D4, D5, D6) = (0, 1, 1, 0)	0.138	0.145	0.152	V
	V <sub>REF8</sub>	(D3, D4, D5, D6) = (1, 1, 1, 0)	0.133	0.140	0.147	V
	V <sub>REF9</sub>	(D3, D4, D5, D6) = (0, 0, 0, 1)	0.128	0.135	0.142	V
	V <sub>REF10</sub>	(D3, D4, D5, D6) = (1, 0, 0, 1)	0.124	0.130	0.137	V
	V <sub>REF11</sub>	(D3, D4, D5, D6) = (0, 1, 0, 1)	0.119	0.125	0.131	V
	V <sub>REF12</sub>	(D3, D4, D5, D6) = (1, 1, 0, 1)	0.114	0.120	0.126	V
	V <sub>REF13</sub>	(D3, D4, D5, D6) = (0, 0, 1, 1)	0.109	0.115	0.121	V
	V <sub>REF14</sub>	(D3, D4, D5, D6) = (1, 0, 1, 1)	0.105	0.110	0.116	V
	V <sub>REF15</sub>	(D3, D4, D5, D6) = (0, 1, 1, 1)	0.100	0.105	0.110	V
	V <sub>REF16</sub>	(D3, D4, D5, D6) = (1, 1, 1, 1)	0.095	0.100	0.105	V
Motor holding drive switching rate	R <sub>hold</sub>			33		%
Logic pin input current	I <sub>INL</sub>	V <sub>IN</sub> = 0V (CLK3/ENA6)			1.0	μA
	I <sub>INH</sub>	V <sub>IN</sub> = 3.3V (CLK3/ENA6)		33	50	μA
High-level input voltage	V <sub>INH</sub>	CLK3/ENA6	2.5			V
Low-level input voltage	V <sub>INL</sub>	CLK3/ENA6			1.0	V
<b>Photosensor peripheral circuits (PI1, PI2, BI1, BO1, BI2, BO2)</b>						
Output on-resistance 3	R <sub>on3a</sub>	I <sub>O</sub> = 20mA, PI1, PI2		2.4	5	Ω
	R <sub>on3b</sub>	I <sub>O</sub> = 40mA, PI1, PI2		2.4	5	Ω
Output leakage current 3	I <sub>Oleak3</sub>	PI1, PI2			1	μA
Schmitt buffer threshold level (hysteresis)	V <sub>thH</sub>		1.00	1.28	1.50	V
	V <sub>thL</sub>		0.60	0.84	1.10	V
Schmitt buffer hysteresis	V <sub>thhys1</sub>		0.3	0.44	0.6	V
Schmitt buffer threshold level (no hysteresis)	V <sub>th</sub>		0.90	1.20	1.40	V
<b>Serial Data Transfer Pins</b>						
Logic pin input current	I <sub>INL</sub>	V <sub>IN</sub> = 0V (SCLK, DATA, STB)			1.0	μA
	I <sub>INH</sub>	V <sub>IN</sub> = 3.3V (SCLK, DATA, STB)		33	50	μA
High-level input voltage	V <sub>INH</sub>	SCLK, DATA, STB	2.5			V
Low-level input voltage	V <sub>INL</sub>	SCLK, DATA, STB			1.0	V
Minimum SCLK high-level pulse width	T <sub>sch</sub>		0.125			μS
Minimum SCLK low-level pulse width	T <sub>scl</sub>		0.125			μS
Stipulated STB time	T <sub>lat</sub>		0.125			μS
Minimum STB pulse width	T <sub>latw</sub>		0.125			μS
Data setup time	T <sub>ds</sub>		0.125			μS
Data hold time	T <sub>dh</sub>		0.125			μS
Maximum CLK frequency	F <sub>clk</sub>				4	MHz

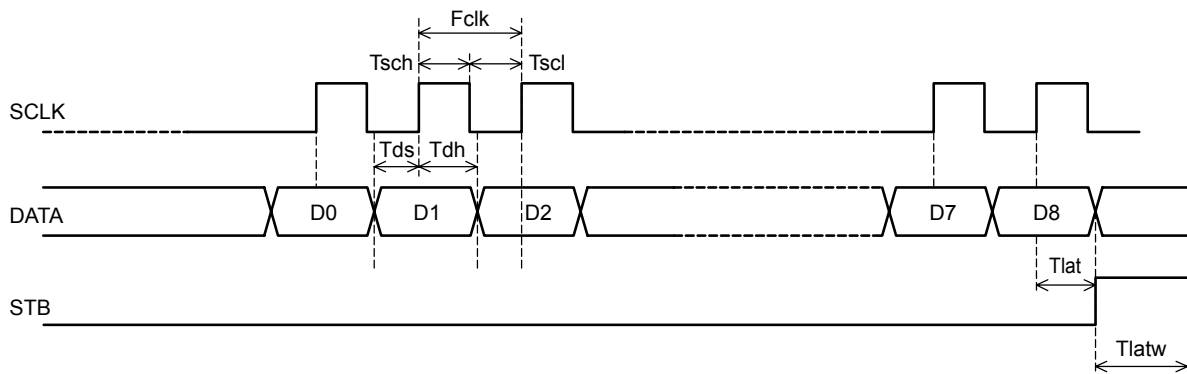

# LV8048CS

## Package Dimensions

unit : mm (typ)

3389

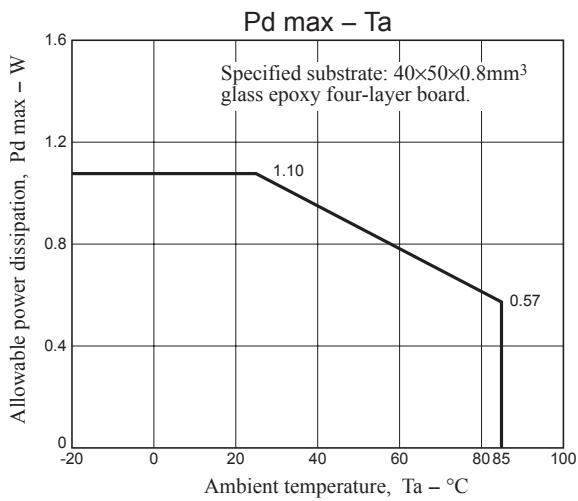
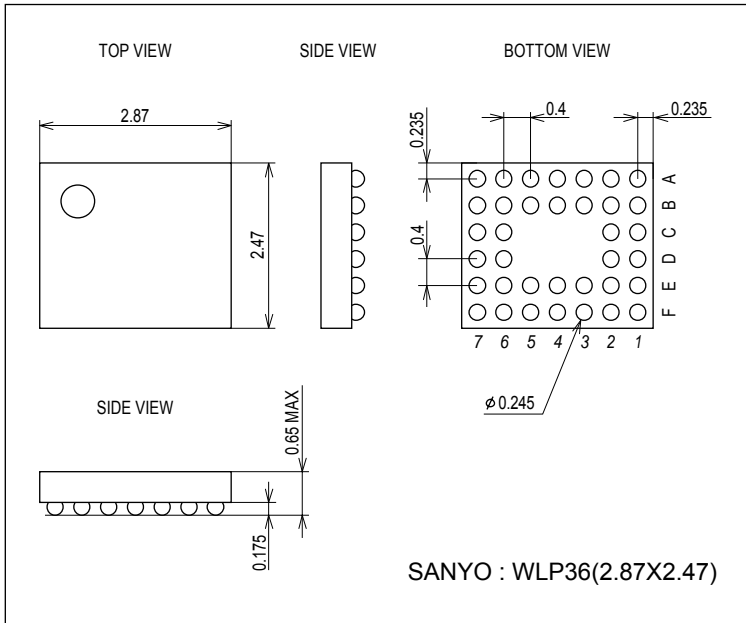

## Pin Assignment

### Bottom View

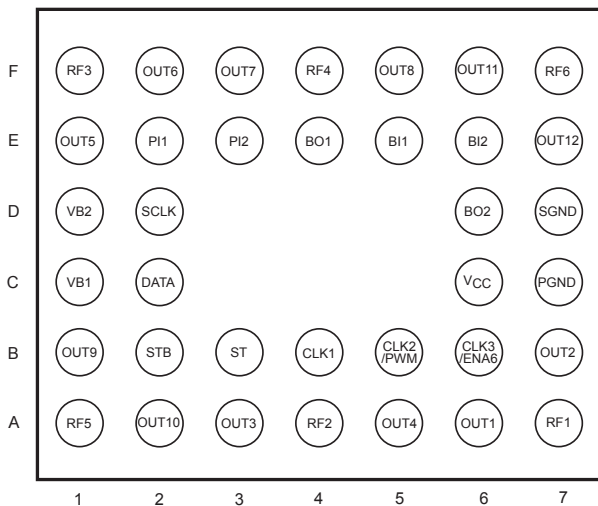

### Top View

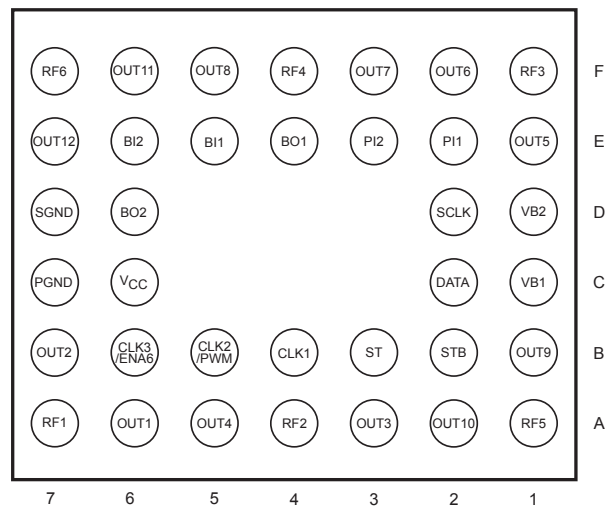

Block Diagram

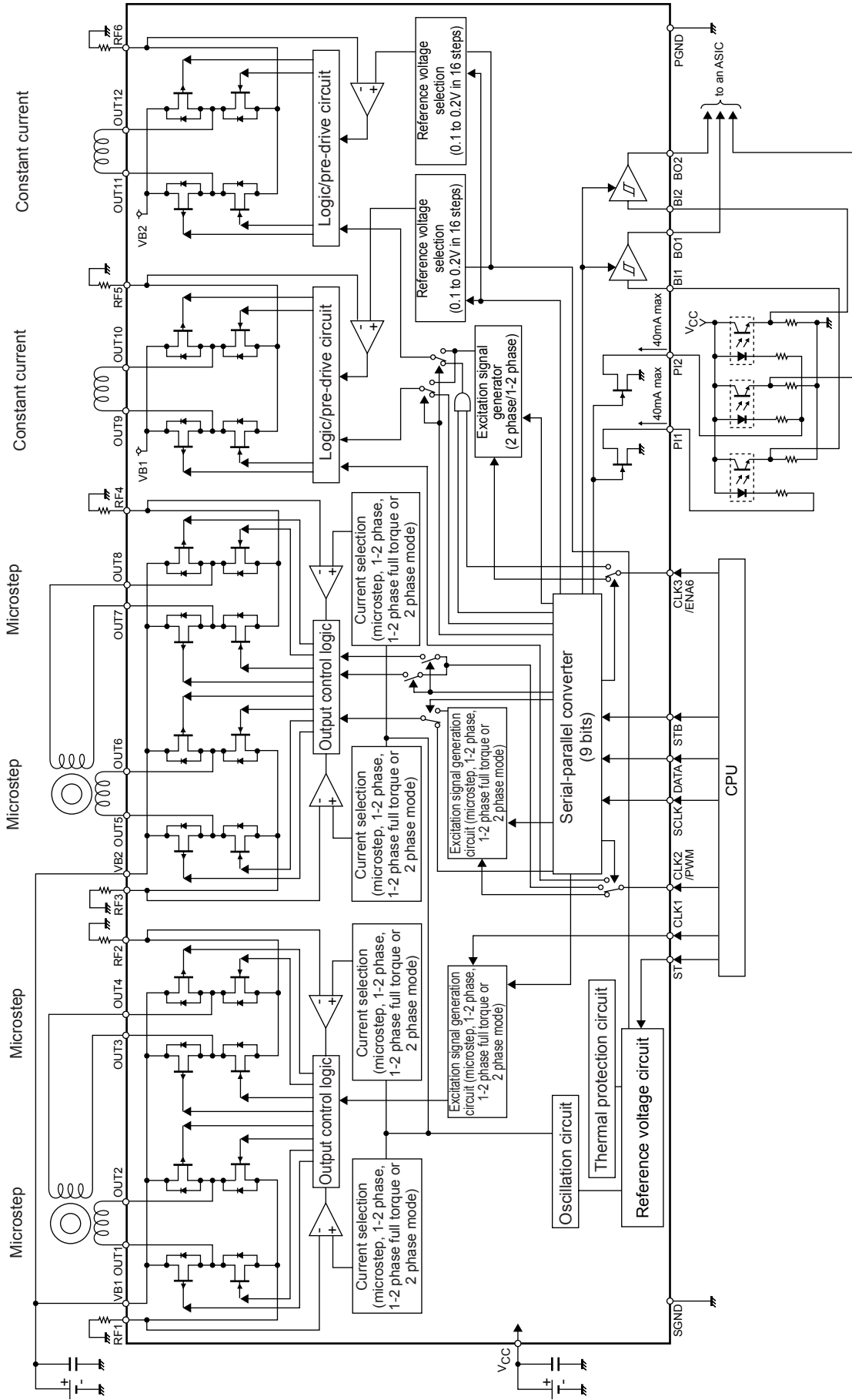

# LV8048CS

## Pin Functions

Pin No.	Pin name	Description
C1	VB1	Power supply for OUT1-4, OUT9-10
D1	VB2	Power supply for OUT5-8, OUT11-12
C7	PGND	Power system ground
C6	V <sub>CC</sub>	Control system power supply
D7	SGND	Control system ground
A6	OUT1	Motor driver output
B7	OUT2	Motor driver output
A3	OUT3	Motor driver output
A5	OUT4	Motor driver output
E1	OUT5	Motor driver output
F2	OUT6	Motor driver output
F3	OUT7	Motor driver output
F5	OUT8	Motor driver output
B1	OUT9	Motor driver output
A2	OUT10	Motor driver output
F6	OUT11	Motor driver output
E7	OUT12	Motor driver output
A7	RF1	Current detection connection for OUT1-2
A4	RF2	Current detection connection for OUT3-4
F1	RF3	Current detection connection for OUT5-6
F4	RF4	Current detection connection for OUT7-8
A1	RF5	Current detection connection for OUT9-10
F7	RF6	Current detection connection for OUT11-12
E2	PI1	Photosensor drive output
E3	PI2	Photosensor drive output
E5	BI1	Schmitt buffer input 1
E4	BO1	Schmitt buffer output 1
E6	BI2	Schmitt buffer input 2
D6	BO2	Schmitt buffer output 2
B3	ST	Chip enable
D2	SCLK	Serial data transfer clock
C2	DATA	Serial data
B2	STB	Serial data latch pulse input
B4	CLK1	Stepping motor clock for OUT1-4
B5	CLK2/PWM	Stepping motor clock for OUT5-8/PWM input for OUT5-8/PWM input for OUT9-10
B6	CLK3/ENA6	Stepping motor clock for OUT9-12/Enable input for OUT11-12

**Serial Data Input Overview**

**Serial Data Input Timing Chart**

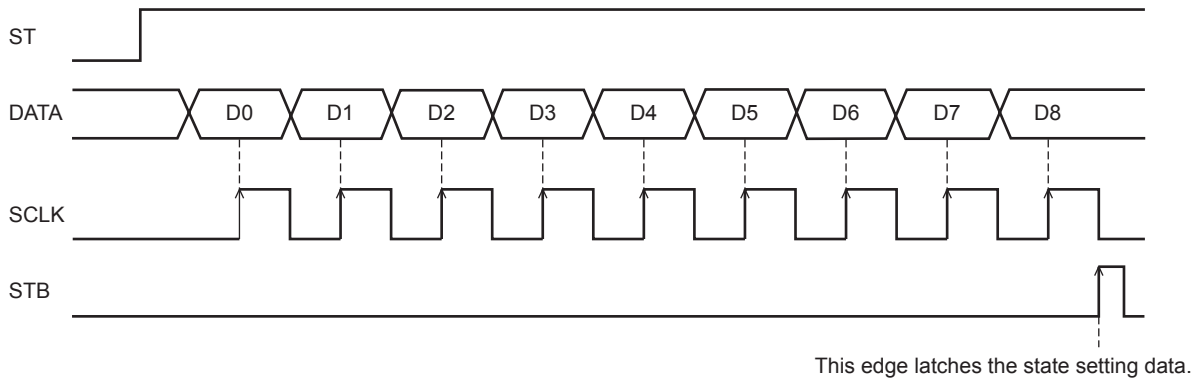

Data is input in order from D0 to D8. Data is transferred on the SCLK rising edge and, after all data has been transferred, the data is latched by the rising edge of the STB signal.

Note that the IC internal circuits will not accept the SCLK signal while the STB signal is high.

**Timing with which the Serial Data is Reflected in the Outputs**

Basically, the new values are reflected in the output at the point the data is latched with the STB signal. → Pattern 1

However, the "Excitation direction" and "Excitation mode" settings used in stepping motor clock drive mode for channels 1 through 4 are an exception. In this case only, after the data is latched with the STB signal, the new values are reflected on the next rising edge of the CLK1 signal and CLK2 signal. → Pattern 2

(Similarly, the "Excitation direction" and "Excitation mode" settings used in the stepping motor clock drive mode for channels 5 to 6 are also an exception. After the data is latched with the STB signal, the new values are reflected on the next rising edge of the CLK3 signal.)

[Pattern 1]

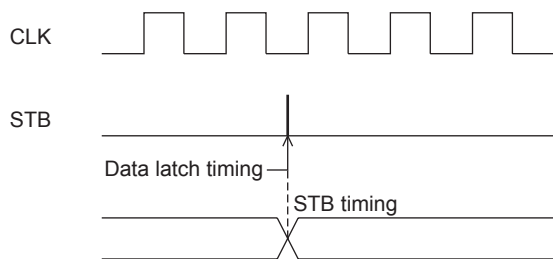

[Pattern 2]

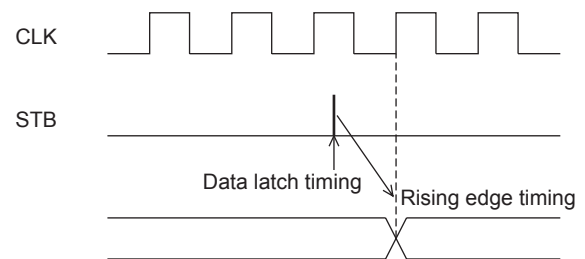

## Detailed Description of Serial Data Input

Note: This IC's channels are assigned as follows.

OUT1/OUT2	→	Channel 1
OUT3/OUT4	→	Channel 2
OUT5/OUT6	→	Channel 3
OUT7/OUT8	→	Channel 4
OUT9/OUT10	→	Channel 5
OUT11/OUT12	→	Channel 6

### Stepping motor excitation type for channels 1 through 6

This IC supports connecting stepping motors to channels 1 and 2 and 3 and 4 to channels 5 and 6. Either of these stepping motors can be controlled by a single clock signal.

When this capability is used, the clock signal input pins and the channels as associated as shown below.

CLK1 :	Controls channel 1 and 2 drive
CLK2/PWM :	Controls channel 3 and 4 drive
CLK3/ENA6 :	Controls channel 5 and 6 drive

The following state settings related to control of these stepping motors are set using the serial data. (See subsection, Serial Logic Table 1, 2, in section ,Truth Tables, for a detailed description of this data.)

#### [For channel 1 to 4 drive]

- Excitation mode : 2-phase, 1-2 phase (full torque), 1-2 phase or microstep
- Microstep division number : 256 or 128
- Excitation direction : CW (clockwise) or CCW (counterclockwise)
- Step/hold : Clear or Hold
- Counter reset: Clear or Reset
- Output enable : Output Off or Output On
- Chopping frequency : Selects one of four values
- Current setting reference voltage : Selects one of four values



#### [For channel 5, 6 drive]

- Excitation mode : 2-phase, 1-2 phase
- Excitation direction : CW (clockwise) or CCW (counterclockwise)
- Step/hold : Clear or Hold
- Counter reset : Clear or Reset
- Output enable : Output Off or Output On



# LV8048CS

[CLK1] pin function

input		operational mode
ST	CLK1	
L	*	standby mode
H		excitation step sending
H		excitation step maintenance

[CLK2/PWM] possession [CLK3/ENA6] similar

Excitation mode setting : (D0 = [1], D1 = [0], D2 = [0], D3 = [0])

D4	D5	D6	excitation mode	イニシャル位置	
				1ch	2ch
0	0	*	2-phase	100%	-100%
1	0	*	1-2 phase (full torque)	100%	0%
0	1	*	1-2 phase	100%	0%
1	1	0	microstep (256step)	100%	0%
		1	microstep (128step)		

It is an initial position in each excitation mode when the counter is reset the state in the early starting up the power supply.

The serial data for standard voltage setting : (D0 = [0], D1 = [1], D2 = [1], D3 = [0])

D6	D7	Current setting and standard voltages
0	0	0.2V
1	0	0.140V
0	1	0.1V
1	1	0.060V

A standard voltage for the current the setting and the standard voltage output current setting can be switched to four stages by the serial data.

It is effective for the power saving when the motor energizes maintenance.

(Computational method of set current value)

A standard voltage can set the output current from the RF resistance connected between standard voltage and terminal RF-GND because it is changeability can (0.2V,0.140V,0.1V,0.060V) in the serial data.

$$I_{OUT} = (\text{Standard voltage} \times \text{Set current ratio}) / \text{RF resistance}$$

(example)The following output current flows in 100% and the RF resistance 1Ω compared with 0.2V in a standard voltage and set currents at times.

$$I_{OUT} = 0.2V \times 100\% / 1\Omega = 200mA$$

Chopping frequency setting

The oscillation circuit is built into in IC, and the chopping frequency of the constant current control can be switched by setting serial data 0110, D4, D5, and \*\*\*.

DATA[4]	DATA[5]	chopping frequency
0	0	390kHz
1	0	195kHz
0	1	570kHz
1	1	285kHz

# LV8048CS

## Excitation Mode Setting

This section presents the timing charts for each excitation mode.

### Two-Phase Excitation Timing Chart

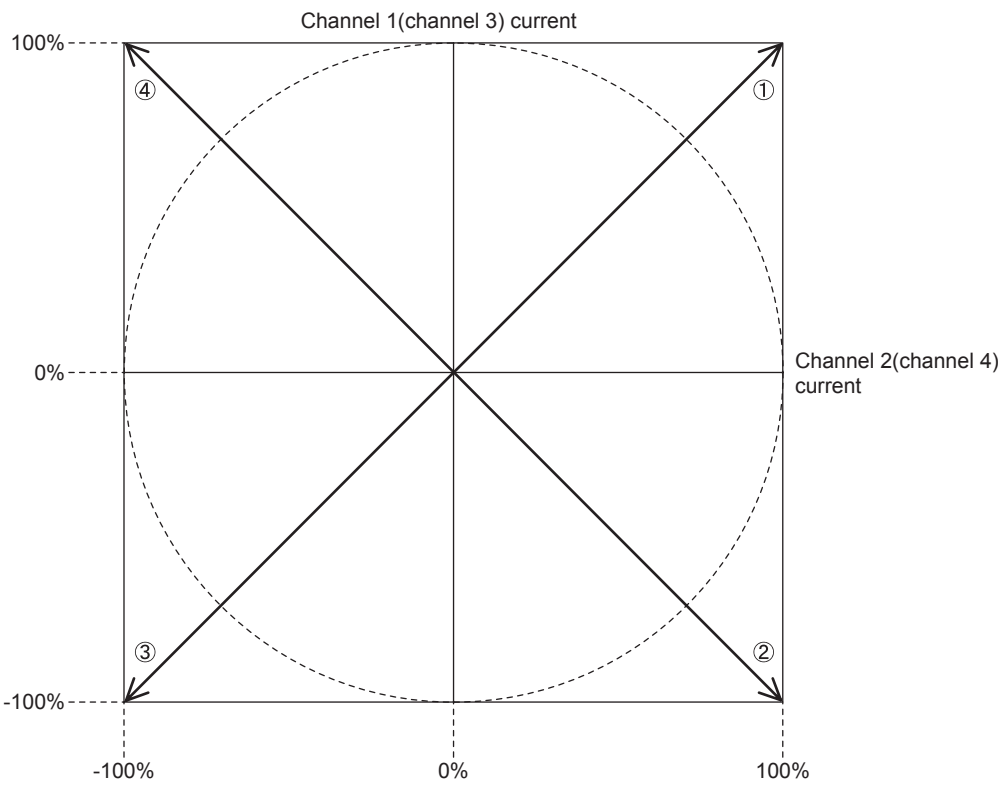
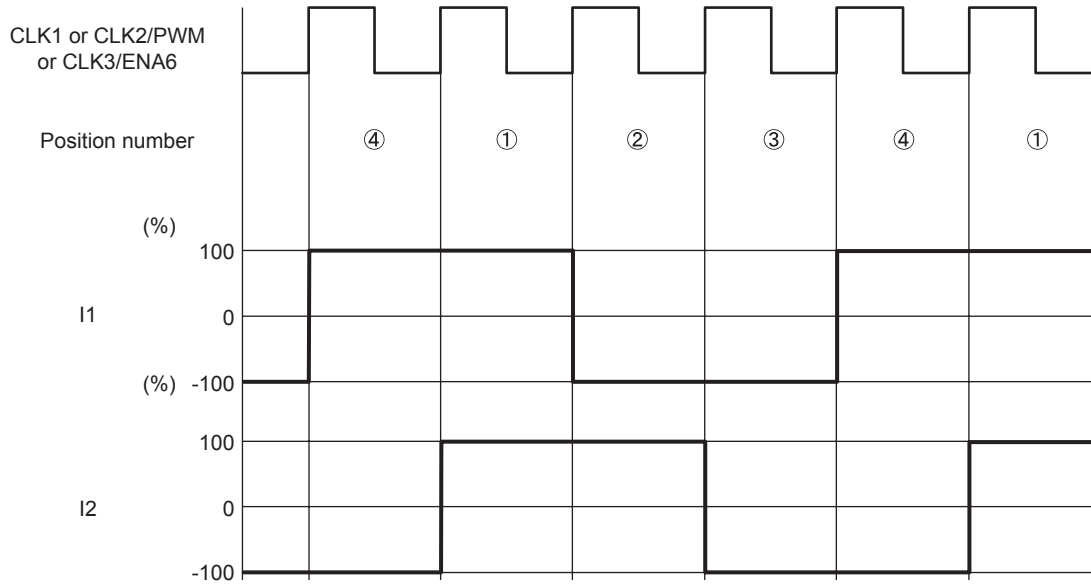

# LV8048CS

## 1-2 phase (full torque) Excitation Timing Chart

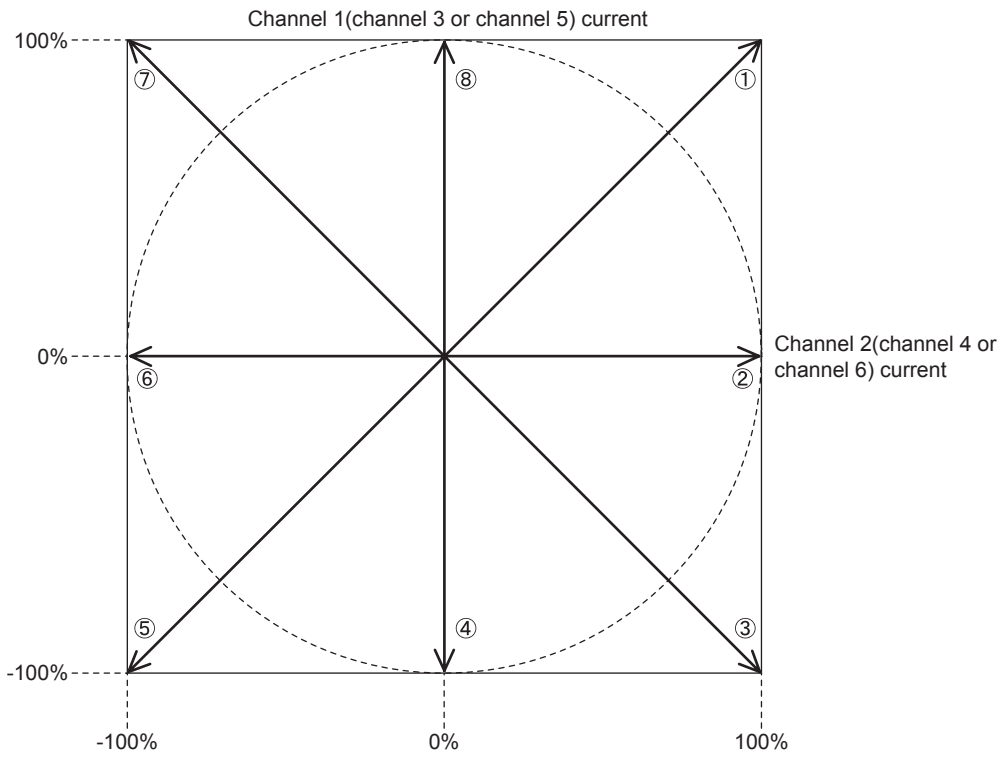
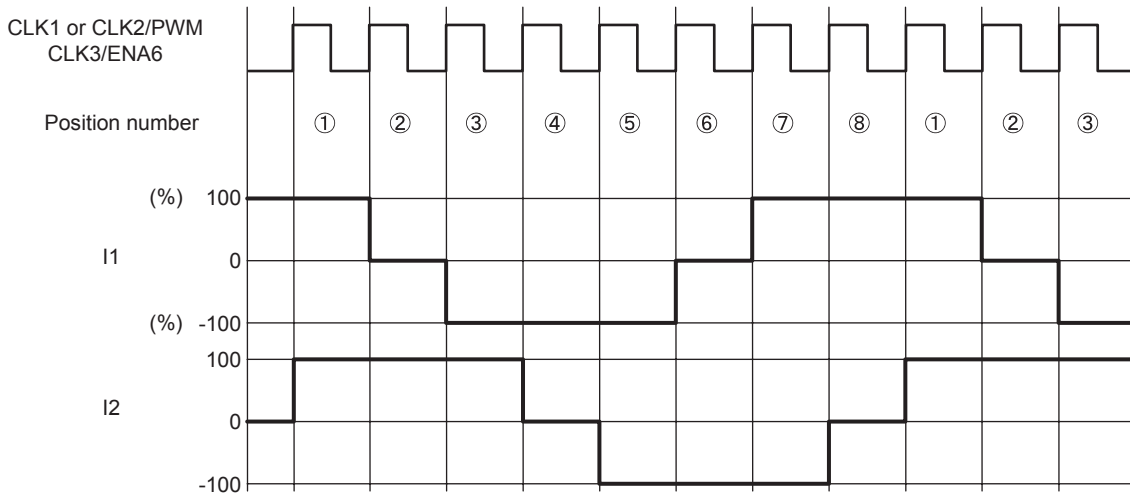

# LV8048CS

## 1-2 Phase Excitation Timing Chart

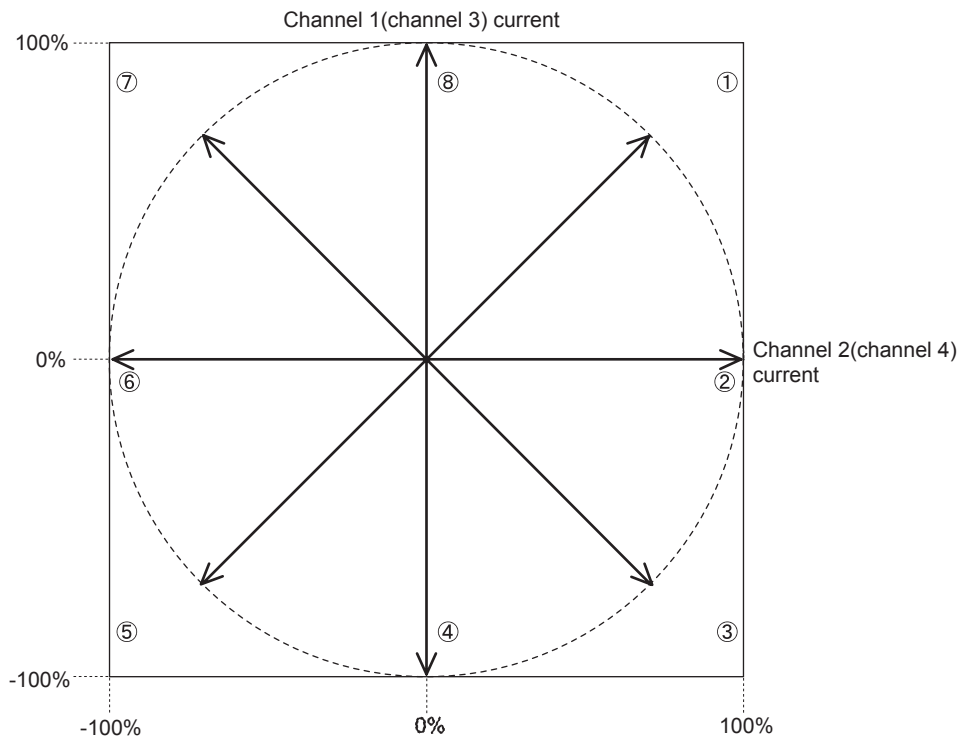
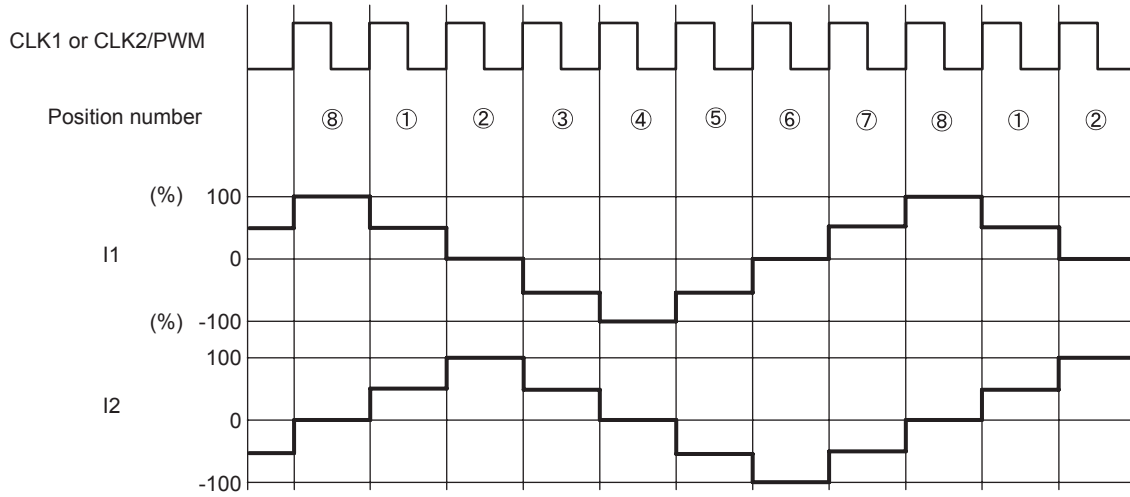

# LV8048CS

## 128-division microstep Timing Chart

Ichi of the motor also similarly moves 128-division microstep and 256-division microstep at the time of each standing up of CLK.

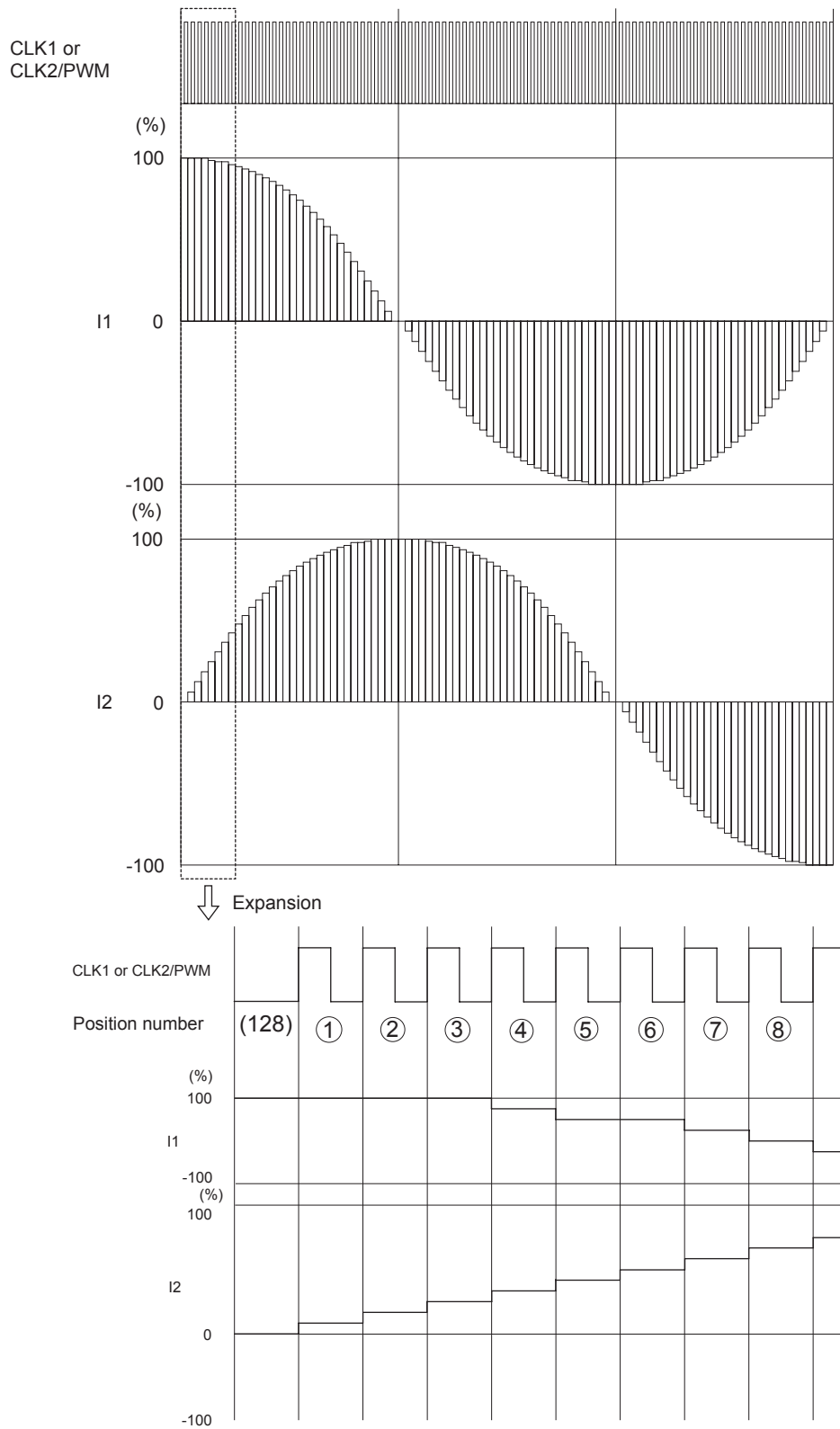

256-division microstep Timing Chart

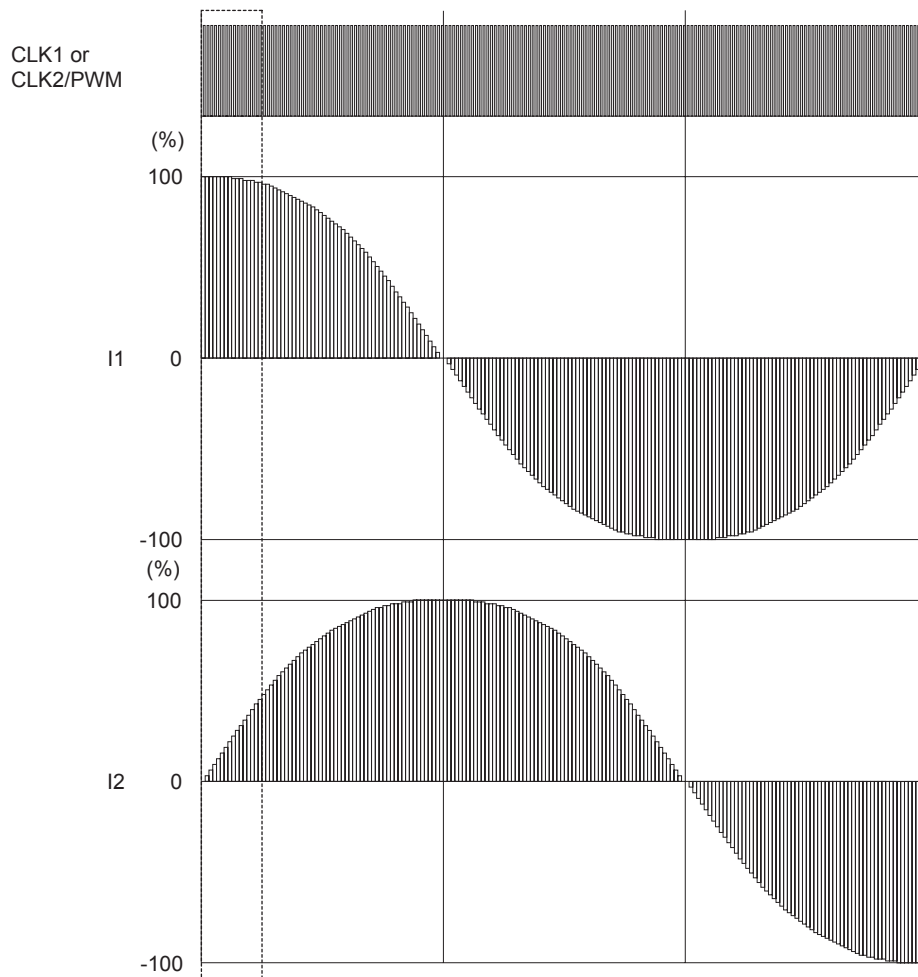

Expansion

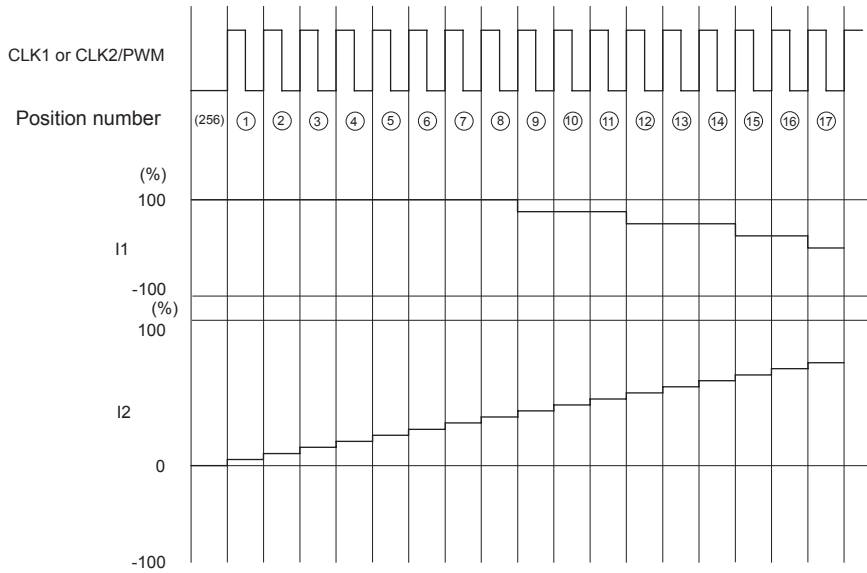

# LV8048CS

## Operation when excitation mode of operation is changed

Change to microstep(256-division or 128-division)

After the change, it moves to the following position of microstep by the first pulse when changing to microstep(256-division or 128-division) from each excitation mode.

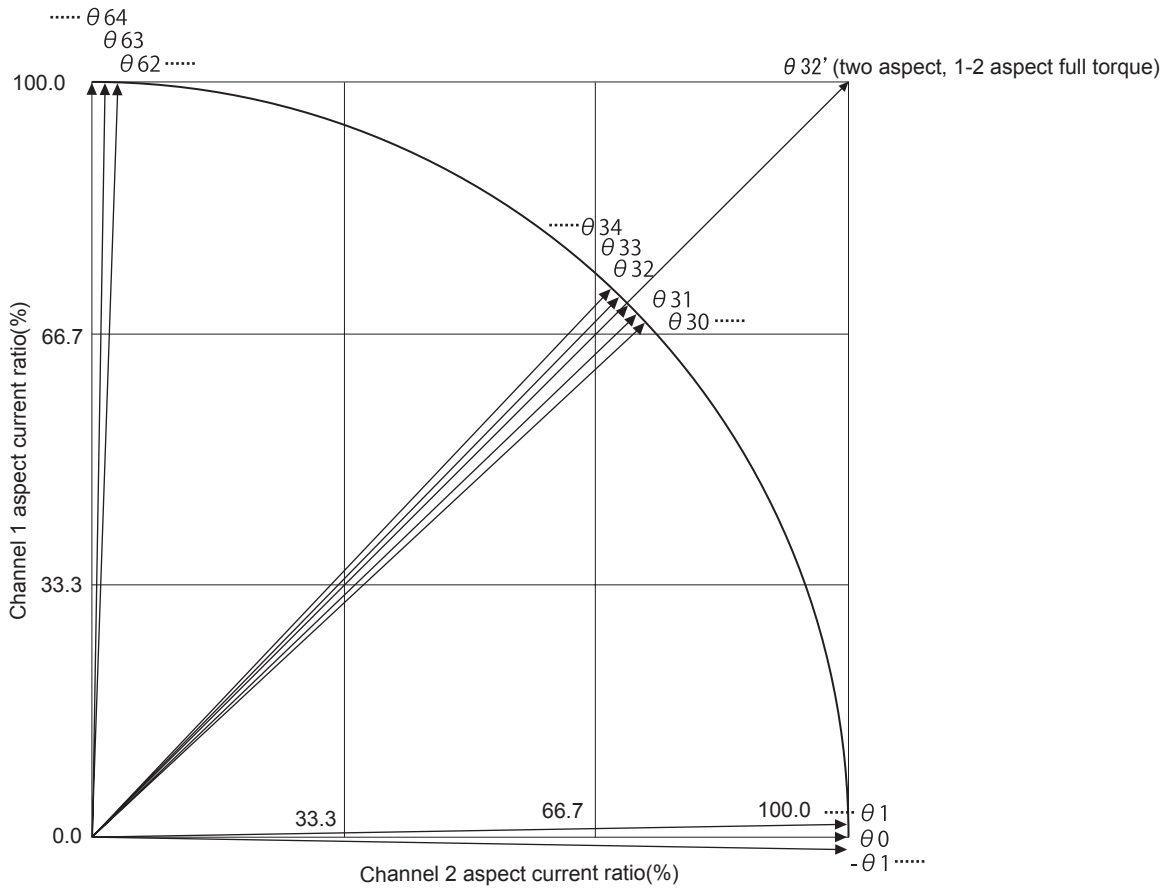

Before the change of the excitation mode		Step position of excitation mode	
excitation mode	position	256-division microstep	128-division microstep
256-division microstep	064	/	062
	063 to 033		062 to 032
	032		030
	031 to 01		030 to 00
	00		-02
128-division microstep	064	063	/
	063 to 033	062 to 032	
	032	031	
	031 to 01	030 to 00	
	00	-01	
1-2 phase	064	063	062
	032	031	030
	00	-01	-02
1-2 phase full torque	064	063	062
	032'	031	030
	00	-01	-02
two phase	032'	031	030

# LV8048CS

## Change to 1-2 aspect excitation (1-2 aspect excitation full torque)

It moves to  $\theta 32(\theta 32')$  by the first pulse after the change when changing to 1-2 aspect excitation (1-2 aspect exciting full torque) from each excitation mode, and it shifts to 1-2 aspect excitation (1-2 aspect exciting full torque) afterwards.

However, after the change, it moves to the following position of 1-2 aspect excitation (1-2 aspect exciting full torque) by the first pulse when the position of the previous state of the change is  $\theta 32(\theta 32')$ .

## Change to two aspect excitation

It moves to  $\theta 32'$  by the first pulse after the change when changing from 1ch to two aspect excitation from each excitation mode for 4ch, and it moves to the following position of two aspect excitation afterwards. However, after the change, it moves to the following position by the first pulse for 5ch and 6ch.

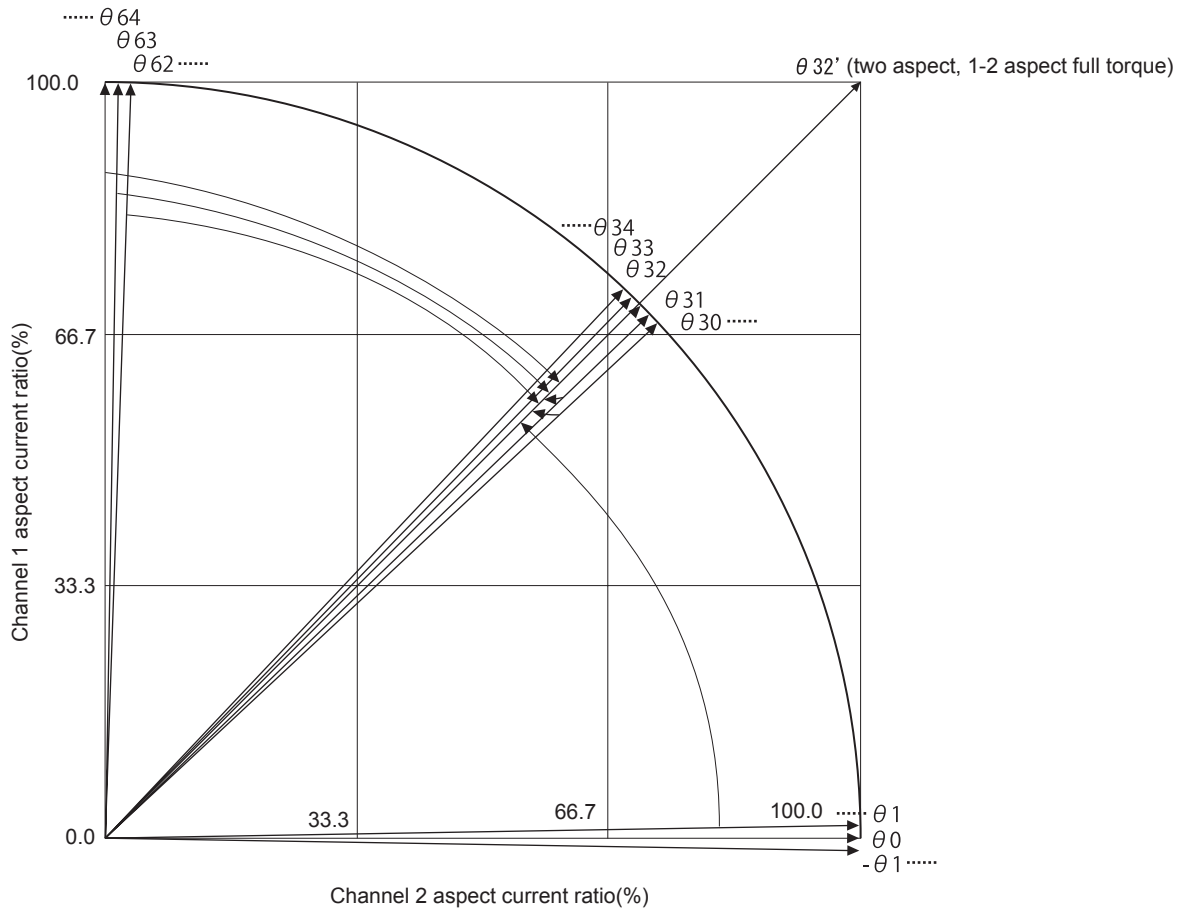

Before the change of the excitation mode		Step position of excitation mode		
excitation mode	position	1-2 phase	1-2 phase full torque	two phase
256-division microstep	$\theta 64$	$\theta 32$	$\theta 32'$	$\theta 32'$
	$\theta 63$ to $\theta 33$	$\theta 32$	$\theta 32'$	$\theta 32'$
	$\theta 32$	$\theta 0$	$\theta 0$	$\theta 32'$
	$\theta 31$ to $\theta 1$	$\theta 32$	$\theta 32'$	$\theta 32'$
	$\theta 0$	$-\theta 32$	$-\theta 32'$	$-\theta 32'$
128-division microstep	$\theta 64$	$\theta 32$	$\theta 32'$	$\theta 32'$
	$\theta 63$ to $\theta 33$	$\theta 32$	$\theta 32'$	$\theta 32'$
	$\theta 32$	$\theta 0$	$\theta 0$	$\theta 32'$
	$\theta 31$ to $\theta 1$	$\theta 32$	$\theta 32'$	$\theta 32'$
	$\theta 0$	$-\theta 32$	$-\theta 32'$	$-\theta 32'$
1-2 phase	$\theta 64$	/	$\theta 32'$	$\theta 32'$
	$\theta 32$		$\theta 0$	$\theta 32'$
	$\theta 0$		$-\theta 32'$	$-\theta 32'$
1-2 phase full torque	$\theta 64$	$\theta 32$	/	$\theta 32'(\theta 32')$
	$\theta 32'$	$\theta 0$		$\theta 32'(-\theta 32')$
	$\theta 0$	$-\theta 32$		$-\theta 32'(-\theta 32')$
two phase	$\theta 32'$	$\theta 0$	$\theta 0(\theta 0)$	/

\*( $\theta$ ) In the inside, for 5ch and 6ch



# LV8048CS

## Sample Timing Chart for the Excitation Direction Setting

The excitation direction setting sets the excitation (rotation) direction of the stepping motor.  
With the CW (clockwise) setting, the phase of the channel 2 current is delayed from that of the channel 1 current by 90°.  
With the CCW (counterclockwise) setting, the phase of the channel 2 current leads that of the channel 1 current by 90°.  
The same applies for channel 3, 4, 5 and 6 drive.

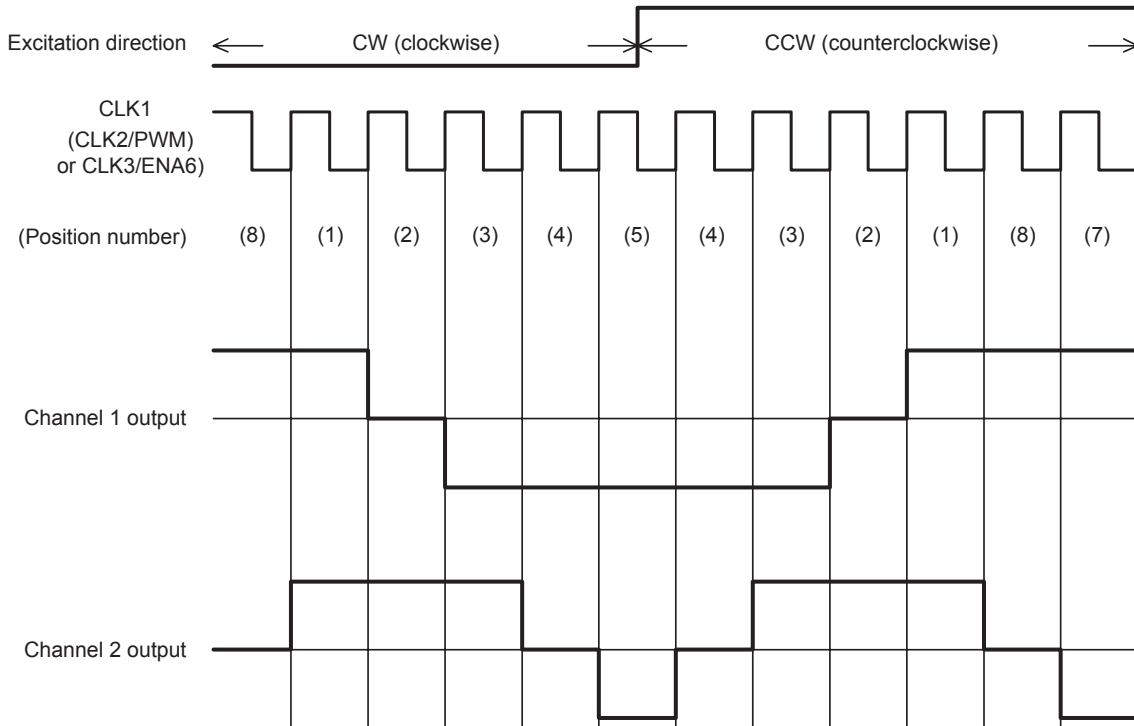

## Step/Hold Operation Overview

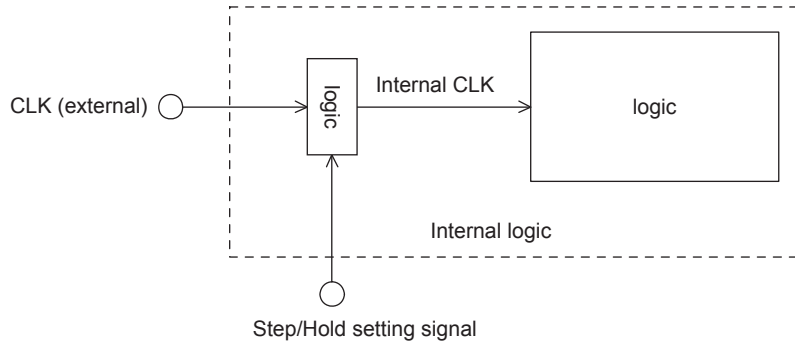

### Sample Timing Chart for the Step/Hold Setting

When the Step/Hold data is set to the Hold state, the state of the external clock signal (CLK) at that time is latched and held as the internal clock signal.

At the timing with which Step/Hold is set to the Hold state for the first time in the figure below, the internal clock signal will be held at the low level because the external clock (CLK) was at the low level. In contrast, at the timing with which Step/Hold is set to the Hold state for the second time, the internal clock signal will be held at the high level because the external clock (CLK) was at the high level.

When Step/Hold is set to the Clear state, the internal clock is synchronized with the external clock (CLK). The output holds the state it was in at the point Step/Hold is set to the Hold state, and advances on the next clock signal rising edge after Step/Hold is set to the Clear state.

As long as Step/Hold is in the Hold state, the position number does not advance even if an external clock (CLK) signal is applied.

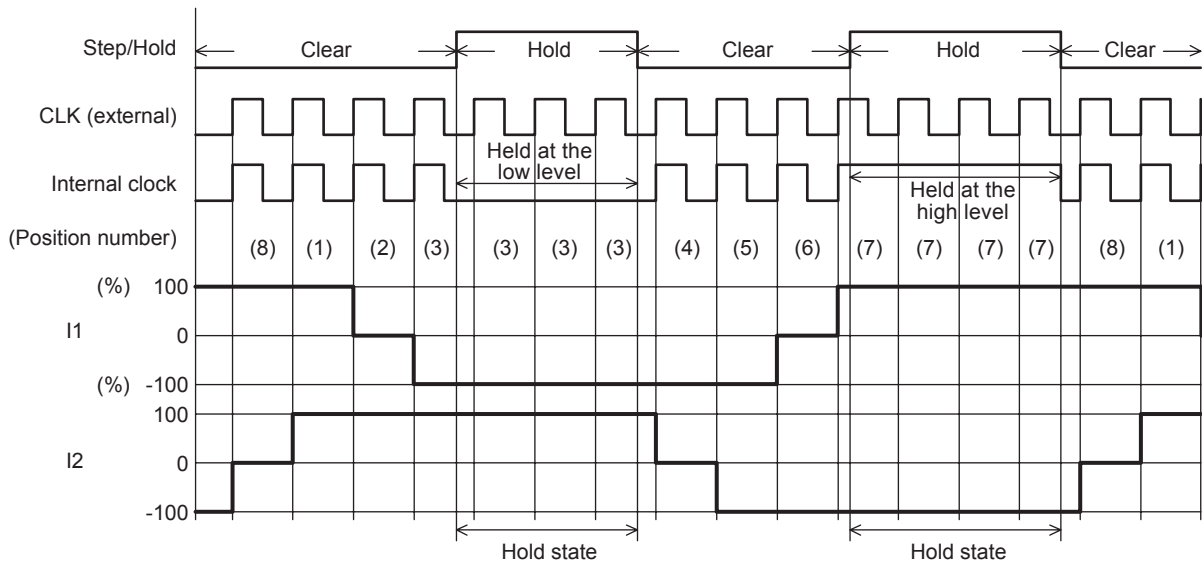

## Sample Timing Chart for the Counter Reset Setting

When the Counter Reset setting is set to the Reset state, the output goes to the initial state on the rising edge of the STB signal. Then, when the Counter Reset setting is set to the Normal Operation (cleared) state, the output begins to advance the position number on the rising edge of the CLK signal following the rise of the STB signal.

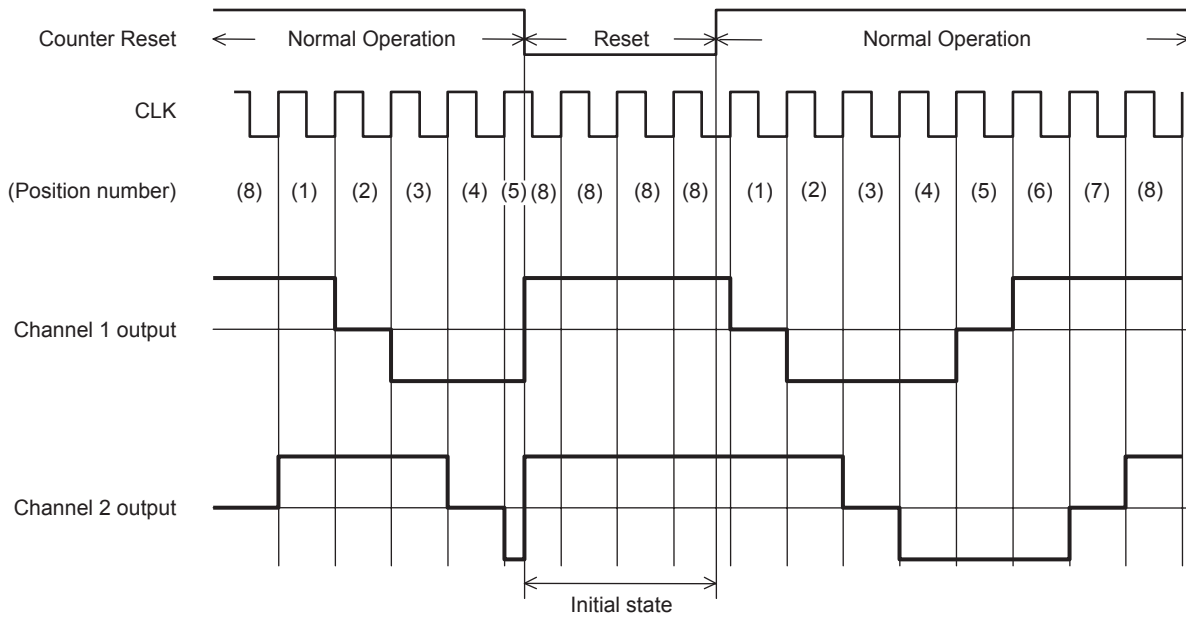

## Sample Timing Chart for the Output Enable Setting

When the Output Enable setting is set to the Output Off state, the outputs are turned off and set to the high-impedance state on the rising edge of the STB signal.

Note, however, that since the internal clock continues to operate, the position number advances as long as a clock signal (CLK) is input. Therefore, when the Output Enable setting is next set to the Output On (cleared) state, the output is turned on at the STB signal rising edge and the output levels at that time will be those for the position number to which the state has advanced due to the CLK signal input.

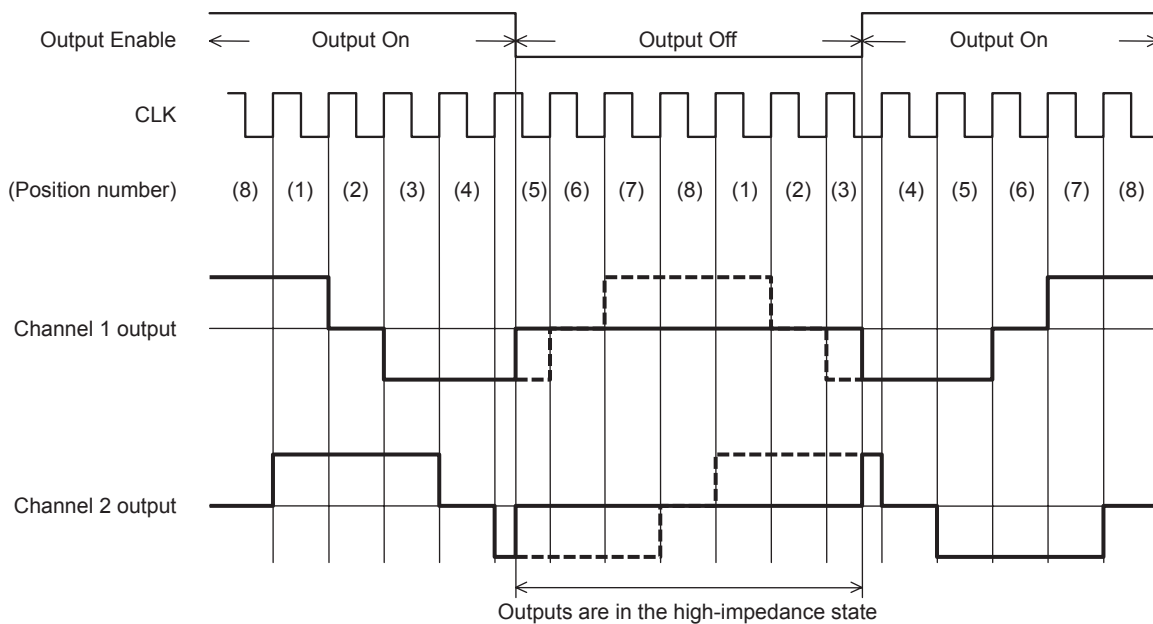

# LV8048CS

## DC Motor and Voice Coil Motor Drive Methods (Channel 3, 4)

When channel 3 or channel 4 is used to drive a DC or voice coil motor, the drive polarity is set with the serial data.

### Setting Procedure

- (1) Set PWM signal input(channel 3 to 4) to CLK2/PWM select with the serial data.  
→This sets up the signal input from the CLK2/PWM pin to be accepted as a PWM signal for channel 3 or channel 4.  
( It doesn't accept as CLK signal.)
- (2) If the output is to be controlled by PWM control, set up PWM mode and PWM signal allocation with the serial data.
- (3) Set the drive polarity for each channel with the serial data.
- (4) If the output is to be controlled by PWM control, input the CLK2/PWM signal to the PWM pin.  
The following tables describe the correspondence between the PWM signal and the output logic.

### Operation in Slow Decay Mode (forward/reverse ↔ brake)

Serial input				PWM input	Output				Mode	
D4	D5	D6	D7	CLK2/PWM	OUT5	OUT6	OUT7	OUT8		
0	0			L	OFF	OFF			Standby mode	
1	0				H	L			OUT5 → OUT6	
0	1				L	H			OUT6 → OUT5	
1	1				L	L			Brake mode	
		0	0					OFF	OFF	Standby mode
		1	0					H	L	OUT7 → OUT8
		0	1					L	H	OUT8 → OUT7
		1	1					L	L	Brake mode
0	0			H	L	L			Brake mode	
1	0				L	L			Brake mode	
0	1				L	L			Brake mode	
1	1				L	L			Brake mode	
		0	0					L	L	Brake mode
		1	0					L	L	Brake mode
		0	1					L	L	Brake mode
		1	1					L	L	Brake mode

### Operation in Fast Decay Mode (forward/reverse ↔ standby mode)

Serial input				PWM input	Output				Mode	
D4	D5	D6	D7	CLK2/PWM	OUT5	OUT6	OUT7	OUT8		
0	0			L	OFF	OFF			Standby mode	
1	0				H	L			OUT5 → OUT6	
0	1				L	H			OUT6 → OUT5	
1	1				L	L			Brake mode	
		0	0					OFF	OFF	Standby mode
		1	0					H	L	OUT7 → OUT8
		0	1					L	H	OUT8 → OUT7
		1	1					L	L	Brake mode
0	0			H	OFF	OFF			Standby mode	
1	0				OFF	OFF			Standby mode	
0	1				OFF	OFF			Standby mode	
1	1				OFF	OFF			Standby mode	
		0	0					OFF	OFF	Standby mode
		1	0					OFF	OFF	Standby mode
		0	1					OFF	OFF	Standby mode
		1	1					OFF	OFF	Standby mode

# LV8048CS

## Voice Coil Motor Drive Methods (channels 5 and 6)

When channel 5 or 6 is used to drive a motor, such as a voice coil motor, the drive polarity is set using the serial data. The setting procedure for each channel is shown below.

[When channel 5 is used]

Set the drive polarity using the serial data.

→The signal is output between OUT9 and OUT10 when the serial data is set.

### Setup steps

The direction where each channel is drive polarity to the serial data.

serial input		output		mode
D4	D5	OUT9	OUT10	
0	0	OFF	OFF	standby mode
1	0	H	L	OUT9 → OUT10
0	1	L	H	OUT10 → OUT9
1	1	L	L	Brake mode

### Channel 5 when you control PWM.

- (1) Set CLK2/PWM selection to “PWM signal input(channel 5)” with the serial data.  
→This sets up the signal input from the CLK2/PWM pin to be accepted as a PWM signal for channel 5.
- (2) Set CLK3/ENA6 selection to “ENA6 signal input” with the serial data.  
→This sets up the signal input from the CLK3/ENA6 pin to be accepted as a ENA signal for channel 6.  
→It comes to be able to set the direction where channel 5 and channel 6 are drive polarity to the serial data.
- (3) Set the drive polarity using the serial data..  
→ The signal is output between OUT9 and OUT10 when the serial data is set.

### Operation in Slow Decay Mode (forward/reverse ↔ brake)

Serial input		PWM input	Output		Mode
D4	D5	CLK2/PWM	OUT9	OUT10	
0	0	L	OFF	OFF	Standby mode
1	0		H	L	OUT9 → OUT10
0	1		L	H	OUT10 → OUT9
1	1		L	L	Brake mode
0	0	H	OFF	OFF	Standby mode
1	0		L	L	Brake mode
0	1		L	L	Brake mode
1	1		L	L	Brake mode

### Operation in Fast Decay Mode (forward/reverse ↔ standby mode)

Serial input		PWM input	Output		Mode
D4	D5	CLK2/PWM	OUT9	OUT10	
0	0	L	OFF	OFF	Standby mode
1	0		H	L	OUT9 → OUT10
0	1		L	H	OUT10 → OUT9
1	1		L	L	Brake mode
0	0	H	OFF	OFF	Standby mode
1	0		OFF	OFF	Standby mode
0	1		OFF	OFF	Standby mode
1	1		L	L	Brake mode

## LV8048CS

[When channel 6 is used]

- (1) Set CLK3/ENA6 selection to “ENA6 signal input” with the serial data.
  - This sets up the signal input from the CLK3/ENA6 pin to be accepted as a ENA signal for channel 6.
  - It comes to be able to set the direction where channel 5 and channel 6 are drive polarity to the serial data.
- (3) Set the drive polarity using the serial data.
  - The signal is output between OUT11 and OUT12 only when ENA6 is set to high.
  - (When ENA6 is low, the signal output between OUT11 and OUT12 is set to OFF.)

### ENA6 input truth table

Serial input		Parallel input	Output		Mode
D6	D7	ENA5	OUT11	OUT12	
*	*	L	OFF	OFF	Standby mode
0	0	H	OFF	OFF	Standby mode
1	0		H	L	OUT11 → OUT12
0	1		L	H	OUT12 → OUT11
1	1		L	L	Brake mode

### Constant Current Control Settings (channels 5 and 6)

The constant current levels for channels 5 and 6 are set as shown below.

The output constant current is set by the constant current reference voltage set with the serial data and the resistor (RF) connected between the RF5 and RF6 pins.

The following formula can be used to calculate the output constant current.

$$(\text{output constant current}) = (\text{constant current reference voltage}) / (\text{value of the resistor RF})$$

reference voltage setting: channel 5 setting(D0 = [0], D1 = [0], D2 = [0], D3 = [1])

channel 6 setting(D0 = [1], D1 = [0], D2 = [0], D3 = [1])

D4	D5	D6	D7	constant current reference voltage
0	0	0	0	0.200V
1	0	0	0	0.170V
0	1	0	0	0.165V
1	1	0	0	0.160V
0	0	1	0	0.155V
1	0	1	0	0.150V
0	1	1	0	0.145V
1	1	1	0	0.140V
0	0	0	1	0.135V
1	0	0	1	0.130V
0	1	0	1	0.125V
1	1	0	1	0.120V
0	0	1	1	0.115V
1	0	1	1	0.110V
0	1	1	1	0.105V
1	1	1	1	0.100V

[Motor holding current mode]

The constant current reference voltages for channels 5 and 6 are switched to one-third levels when the motor holding current is set to ON by the serial data.

### PI1, PI2 Output Drive Method

When the PI1 or PI2 output is used to drive a photosensor, the drive on/off state is set using the serial data.

### Hysteresis settings of Schmitt buffer

The presence or absence of hysteresis in the Schmitt buffer outputs B01 and B02 can be set individually with the serial data.









# LV8048CS

## Equivalent Circuits

Pin No.	Pin name	Equivalent Circuit
E4 D6	BO1 BO2	
A6 A7 B7 A3 A4 A5 E1 F1 F2 F3 F4 F5	OUT1 RF1 OUT2 OUT3 RF2 OUT4 OUT5 RF3 OUT6 OUT7 RF4 OUT8	
F6 F7 E7	OUT11 RF6 OUT12	
C2 B2 D2 B4 B5 B6	DATA STB SCLK CLK1 CLK2/PWM CLK3/ENA6	

Continued on next page.

# LV8048CS

Continued from preceding page.

Pin No.	Pin name	Equivalent Circuit
B3	ST	
B2 A1 A2	OUT10 RF5 OUT9	
E5 E6	B11 B12	
E2 E3	PI1 PI2	

- SANYO Semiconductor Co.,Ltd. assumes no responsibility for equipment failures that result from using products at values that exceed, even momentarily, rated values (such as maximum ratings, operating condition ranges, or other parameters) listed in products specifications of any and all SANYO Semiconductor Co.,Ltd. products described or contained herein.
- SANYO Semiconductor Co.,Ltd. strives to supply high-quality high-reliability products, however, any and all semiconductor products fail or malfunction with some probability. It is possible that these probabilistic failures or malfunction could give rise to accidents or events that could endanger human lives, trouble that could give rise to smoke or fire, or accidents that could cause damage to other property. When designing equipment, adopt safety measures so that these kinds of accidents or events cannot occur. Such measures include but are not limited to protective circuits and error prevention circuits for safe design, redundant design, and structural design.
- In the event that any or all SANYO Semiconductor Co.,Ltd. products described or contained herein are controlled under any of applicable local export control laws and regulations, such products may require the export license from the authorities concerned in accordance with the above law.
- No part of this publication may be reproduced or transmitted in any form or by any means, electronic or mechanical, including photocopying and recording, or any information storage or retrieval system, or otherwise, without the prior written consent of SANYO Semiconductor Co.,Ltd.
- Any and all information described or contained herein are subject to change without notice due to product/technology improvement, etc. When designing equipment, refer to the "Delivery Specification" for the SANYO Semiconductor Co.,Ltd. product that you intend to use.
- Information (including circuit diagrams and circuit parameters) herein is for example only; it is not guaranteed for volume production.
- Upon using the technical information or products described herein, neither warranty nor license shall be granted with regard to intellectual property rights or any other rights of SANYO Semiconductor Co.,Ltd. or any third party. SANYO Semiconductor Co.,Ltd. shall not be liable for any claim or suits with regard to a third party's intellectual property rights which has resulted from the use of the technical information and products mentioned above.

This catalog provides information as of December, 2009. Specifications and information herein are subject to change without notice.