



**7N80**

Preliminary

*Power MOSFET*

**7A, 800V N-CHANNEL  
POWER MOSFET**

■ DESCRIPTION

The UTC **7N80** is an N-channel mode power MOSFET using UTC's advanced technology to provide customers with planar stripe and DMOS technology. This technology specializes in allowing a minimum on-state resistance and superior switching performance. It also can withstand high energy pulse in the avalanche and commutation mode.

The UTC **7N80** is universally applied in high efficiency switch mode power supply.

■ FEATURES

- \*  $R_{DS(on)}=1.8\Omega@V_{GS}=10V$
- \* High switching speed
- \* 100% avalanche tested

■ SYMBOL

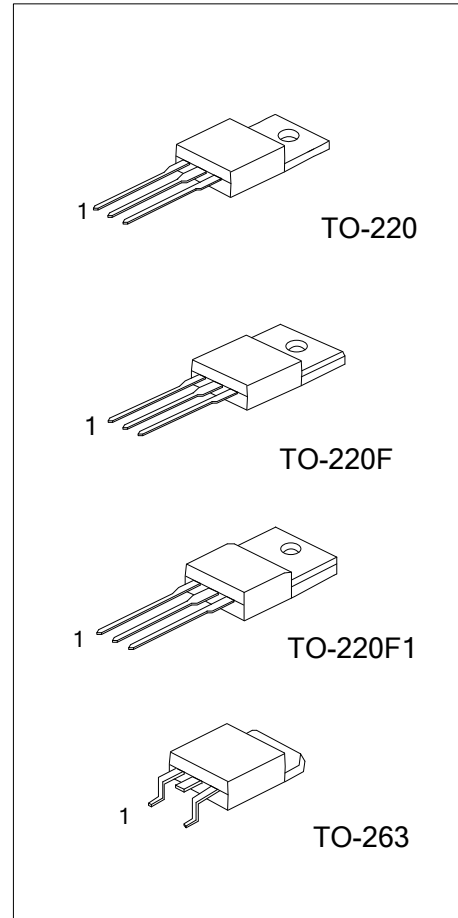
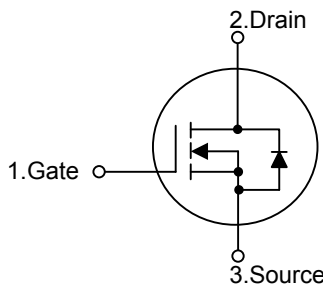

■ ORDERING INFORMATION

Ordering Number		Package	Pin Assignment			Packing
Lead Free	Halogen Free		1	2	3	
7N80L-TA3-T	7N80G-TA3-T	TO-220	G	D	S	Tube
7N80L-TF3-T	7N80G-TF3-T	TO-220F	G	D	S	Tube
7N80L-TF1-T	7N80G-TF1-T	TO-220F1	G	D	S	Tube
7N80L-TQ2-R	7N80G-TQ2-R	TO-263	G	D	S	Tape Reel
7N80L-TQ2-T	7N80G-TQ2-T	TO-263	G	D	S	Tube

Note: Pin Assignment: G: Gate D: Drain S: Source

<p>7N80L - TA3 - T</p> <p>(1) Packing Type (2) Package Type (3) Lead Free</p>	<p>(1) T: Tube, R: Tape Reel (2) TA3: TO-220, TF1: TO-220F1, TF3: TO-220F, TQ2: TO-263 (3) G: Halogen Free, L: Lead Free</p>
---	--

■ ABSOLUTE MAXIMUM RATINGS ( $T_c=25^\circ\text{C}$ , unless otherwise specified)

PARAMETER	SYMBOL	RATINGS	UNIT
Drain-Source Voltage	$V_{DSS}$	800	V
Gate-Source Voltage	$V_{GSS}$	$\pm 30$	V
Drain Current	Continuous	$I_D$	7
	Pulsed (Note 1)	$I_{DM}$	26.4
Avalanche Energy	Single Pulsed (Note 2)	$E_{AS}$	580
	Repetitive (Note 1)	$E_{AR}$	16.7
Peak Diode Recovery $dv/dt$ (Note 3)	$dv/dt$	4.5	V/ns
Power Dissipation	TO-220 / TO-263	$P_D$	142
	TO-220F / TO-220F1		48
Junction Temperature	$T_J$	+150	$^\circ\text{C}$
Storage Temperature	$T_{STG}$	-55~+150	$^\circ\text{C}$

Note: 1. Repetitive Rating: Pulse width limited by maximum junction temperature

2.  $L=25\text{mH}$ ,  $I_{AS}=6.6\text{A}$ ,  $V_{DD}=50\text{V}$ ,  $R_G=25\Omega$ , Starting  $T_J=25^\circ\text{C}$

3.  $I_{SD} \leq 8\text{A}$ ,  $di/dt \leq 200\text{A}/\mu\text{s}$ ,  $V_{DD} \leq BV_{DSS}$ , Starting  $T_J=25^\circ\text{C}$

4. Absolute maximum ratings are those values beyond which the device could be permanently damaged.  
Absolute maximum ratings are stress ratings only and functional device operation is not implied.

■ THERMAL DATA

PARAMETER	SYMBOL	RATINGS	UNIT
Junction to Ambient	$\theta_{JA}$	62.5	$^\circ\text{C}/\text{W}$
Junction to Case	TO-220/TO-263	$\theta_{JC}$	0.88
	TO-220F / TO-220F1		2.6

■ ELECTRICAL CHARACTERISTICS (T<sub>c</sub>=25°C, unless otherwise specified)

PARAMETER	SYMBOL	TEST CONDITIONS	MIN	TYP	MAX	UNIT
<b>OFF CHARACTERISTICS</b>						
Drain-Source Breakdown Voltage	BV <sub>DSS</sub>	V <sub>GS</sub> =0V, I <sub>D</sub> =250μA	800			V
Breakdown Voltage Temperature Coefficient	ΔBV <sub>DSS</sub> /ΔT <sub>J</sub>	I <sub>D</sub> =250μA, Referenced to 25°C		0.93		V/°C
Drain-Source Leakage Current	I <sub>DSS</sub>	V <sub>DS</sub> =800V, V <sub>GS</sub> =0V			10	μA
		V <sub>DS</sub> =640V, T <sub>C</sub> =125°C			100	μA
Gate-Source Leakage Current	Forward	I <sub>GSS</sub>				100
	Reverse					
		V <sub>DS</sub> =0V, V <sub>GS</sub> =-30V			-100	nA
<b>ON CHARACTERISTICS</b>						
Gate Threshold Voltage	V <sub>GS(TH)</sub>	V <sub>DS</sub> =V <sub>GS</sub> , I <sub>D</sub> =250μA	3.0		5.0	V
Drain-Source On-State Resistance	R <sub>DS(ON)</sub>	V <sub>GS</sub> =10V, I <sub>D</sub> =3.3A		1.4	1.8	Ω
Forward Transconductance	g <sub>FS</sub>	V <sub>DS</sub> =50V, I <sub>D</sub> =3.3A (Note 1)		5.5		S
<b>DYNAMIC PARAMETERS</b>						
Input Capacitance	C <sub>ISS</sub>	V <sub>DS</sub> =25V, V <sub>GS</sub> =0V, f=1.0MHz		1290	1680	pF
Output Capacitance	C <sub>OSS</sub>			120	155	pF
Reverse Transfer Capacitance	C <sub>RSS</sub>			10	13	pF
<b>SWITCHING PARAMETERS</b>						
Total Gate Charge	Q <sub>G</sub>	V <sub>DS</sub> =640V, V <sub>GS</sub> =10V, I <sub>D</sub> =6.6A (Note 1,2)		27	35	nC
Gate-Source Charge	Q <sub>GS</sub>			8.2		nC
Gate-Drain Charge	Q <sub>GD</sub>			11		nC
Turn-ON Delay Time	t <sub>D(ON)</sub>	V <sub>DD</sub> =400V, I <sub>D</sub> =6.6A, R <sub>G</sub> =25Ω (Note 1,2)		35	80	ns
Turn-ON Rise Time	t <sub>R</sub>			100	210	ns
Turn-OFF Delay Time	t <sub>D(OFF)</sub>			50	110	ns
Turn-OFF Fall Time	t <sub>F</sub>			60	130	ns
<b>SOURCE- DRAIN DIODE RATINGS AND CHARACTERISTICS</b>						
Maximum Body-Diode Continuous Current	I <sub>S</sub>				6.6	A
Maximum Body-Diode Pulsed Current	I <sub>SM</sub>				26.4	A
Drain-Source Diode Forward Voltage	V <sub>SD</sub>	I <sub>S</sub> =6.6A, V <sub>GS</sub> =0V			1.4	V
Body Diode Reverse Recovery Time	t <sub>rr</sub>	V <sub>GS</sub> =0V, I <sub>S</sub> =6.6A, dI <sub>F</sub> /dt=100A/μs (Note 1)		650		ns
Body Diode Reverse Recovery Charge	Q <sub>RR</sub>				7.0	

Note: 1. Pulse Test: Pulse width ≤ 300μs, Duty cycle ≤ 2%

2. Essentially independent of operating temperature

■ TEST CIRCUITS AND WAVEFORMS

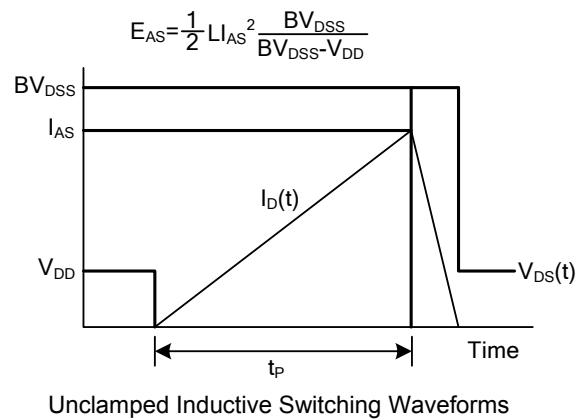
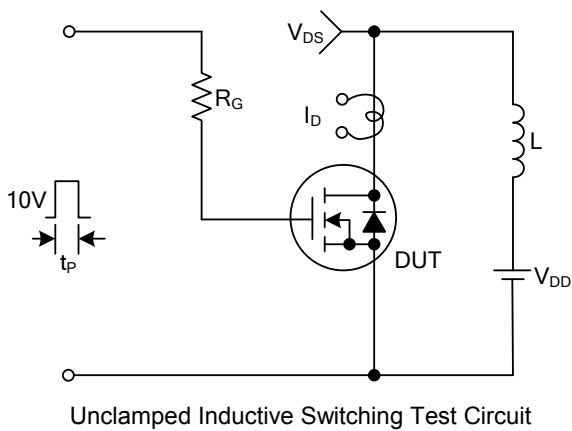
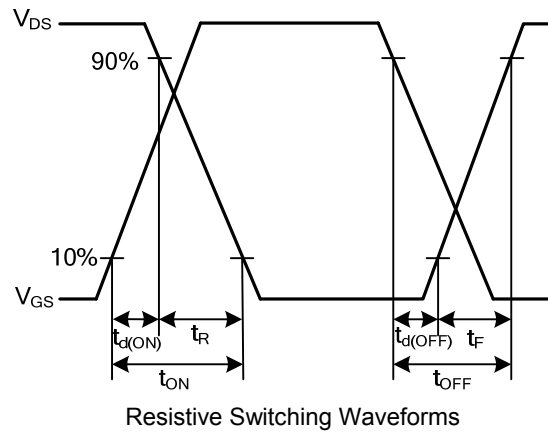
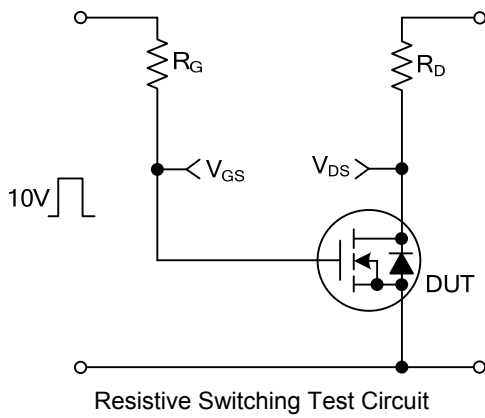
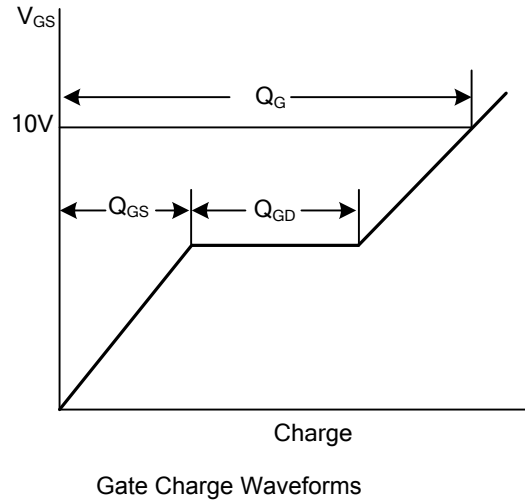
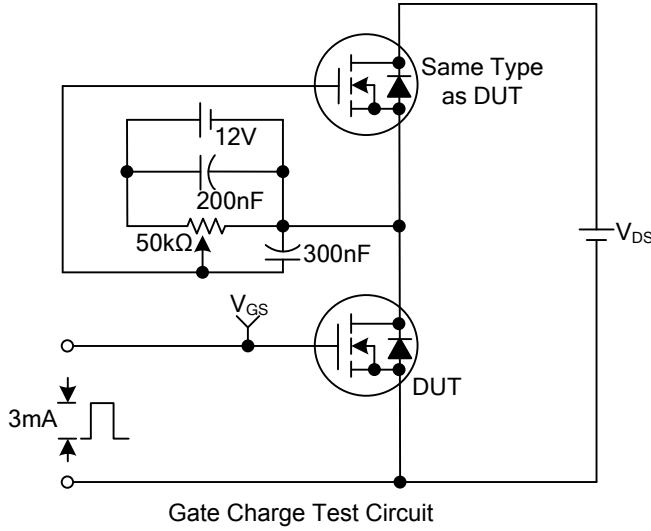

■ TEST CIRCUITS AND WAVEFORMS(Cont.)

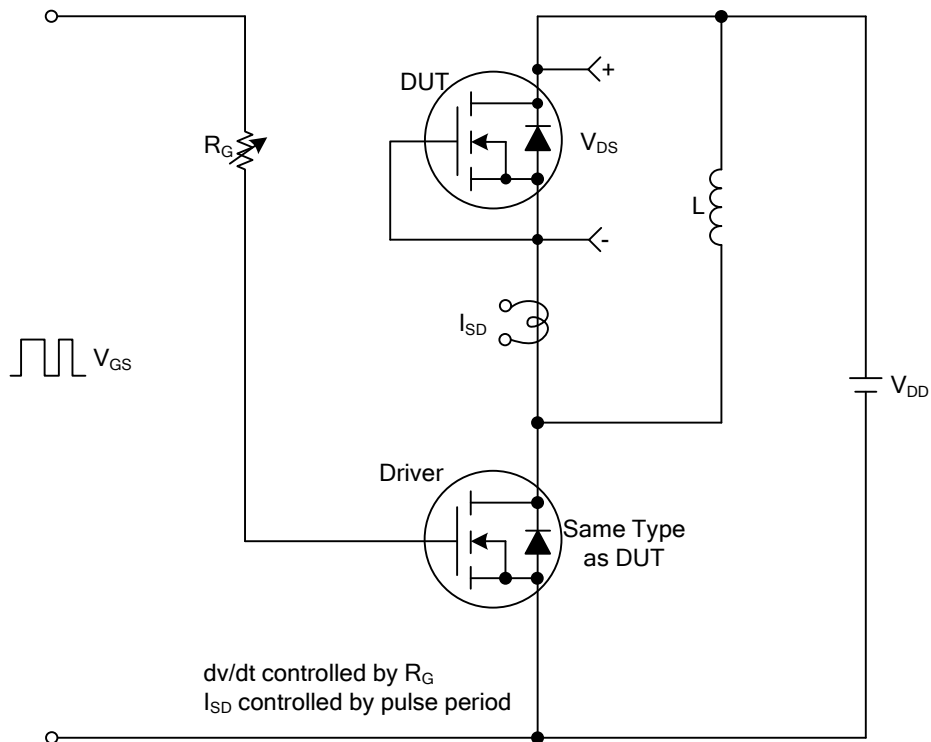

Peak Diode Recovery dv/dt Test Circuit & Waveforms

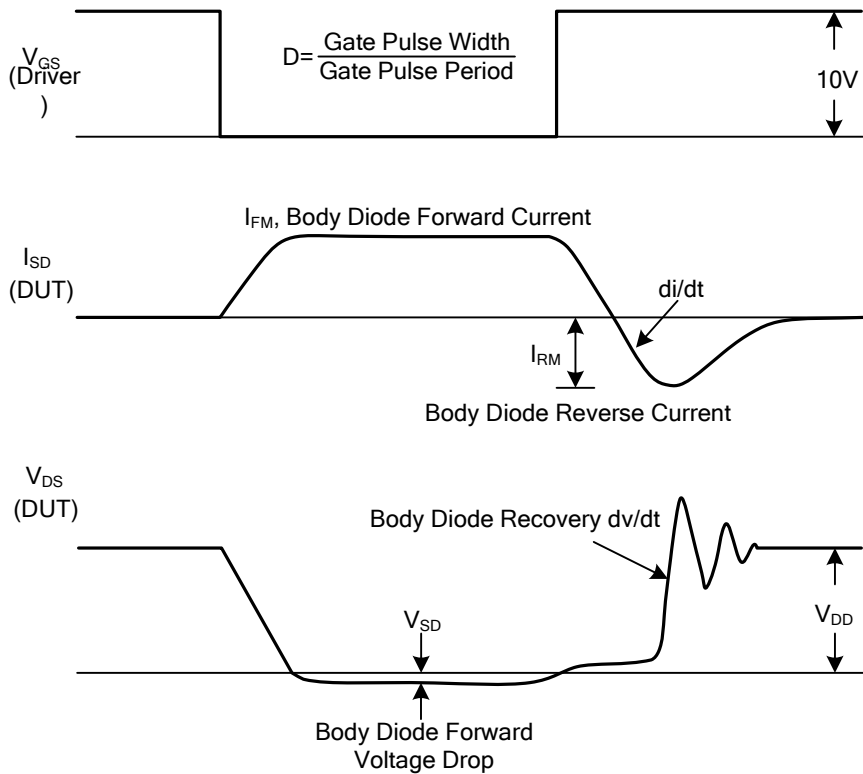

UTC assumes no responsibility for equipment failures that result from using products at values that exceed, even momentarily, rated values (such as maximum ratings, operating condition ranges, or other parameters) listed in products specifications of any and all UTC products described or contained herein. UTC products are not designed for use in life support appliances, devices or systems where malfunction of these products can be reasonably expected to result in personal injury. Reproduction in whole or in part is prohibited without the prior written consent of the copyright owner. The information presented in this document does not form part of any quotation or contract, is believed to be accurate and reliable and may be changed without notice.