



4N70

Power MOSFET

4.4A, 700V N-CANNEL POWER MOSFET

DESCRIPTION

The UTC **4N70** is a high voltage power MOSFET and is designed to have better characteristics, such as fast switching time, low gate charge, low on-state resistance and high rugged avalanche. This high speed switching power MOSFET is usually used in power supplies, PWM motor controls, high efficient DC to DC converters and bridge circuits.

FEATURES

- * $R_{DS(ON)} = 2.8\Omega @ V_{GS} = 10V$
- * Ultra Low Gate Charge (Typical 15nC)
- * Low Reverse Transfer Capacitance ($C_{RSS} = \text{Typical } 8.0 \text{ pF}$)
- * Fast Switching Capability
- * Avalanche Energy Specified
- * Improved dv/dt Capability, High Ruggedness

SYMBOL

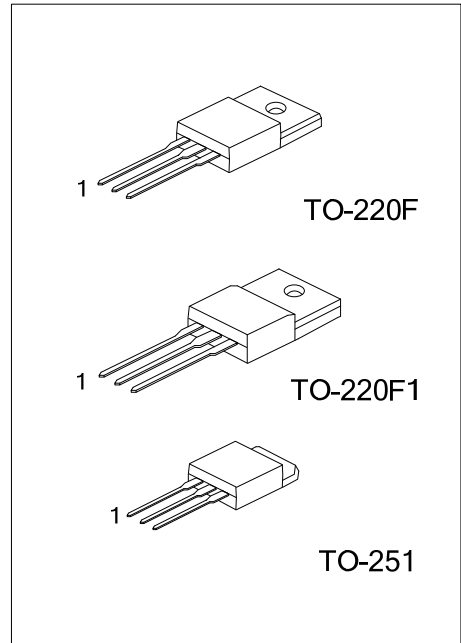
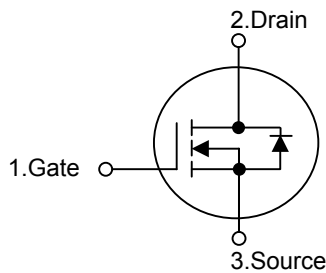

ORDERING INFORMATION

Ordering Number		Package	Pin Assignment			Packing
Lead Free	Halogen Free		1	2	3	
4N70L-TF1-T	4N70G-TF1-T	TO-220F1	G	D	S	Tube
4N70L-TF3-T	4N70G-TF3-T	TO-220F	G	D	S	Tube
4N70L-TM3-T	4N70G-TM3-T	TO-251	G	D	S	Tube

Note: Pin Assignment: G: Gate D: Drain S: Source

<p>4N70L-TF1-T</p> <p>(1) Packing Type (2) Package Type (3) Lead Free</p>	<p>(1) T: Tube (2) TF1: TO-220F1, TF3: TO-220F, TM3: TO-251 (3) G: Halogen Free, L: Lead Free</p>
---	---

■ ABSOLUTE MAXIMUM RATINGS ($T_A = 25^\circ\text{C}$, unless otherwise specified)

PARAMETER		SYMBOL	RATINGS	UNIT
Drain-Source Voltage		V_{DSS}	700	V
Gate-Source Voltage		V_{GSS}	± 30	V
Avalanche Current (Note 2)		I_{AR}	4.4	A
Drain Current	Continuous	I_D	4.4	A
	Pulsed (Note 2)	I_{DM}	17.6	A
Avalanche Energy	Single Pulsed (Note 3)	E_{AS}	260	mJ
	Repetitive (Note 2)	E_{AR}	10.6	mJ
Peak Diode Recovery dv/dt (Note 4)		dv/dt	4.5	V/ns
Power Dissipation	TO-220F/TO-220F1	P_D	36	W
	TO-251		49	
Junction Temperature		T_J	+150	$^\circ\text{C}$
Operating Temperature		T_{OPR}	-55 ~ +150	$^\circ\text{C}$
Storage Temperature		T_{STG}	-55 ~ +150	$^\circ\text{C}$

Notes: 1. Absolute maximum ratings are those values beyond which the device could be permanently damaged.

Absolute maximum ratings are stress ratings only and functional device operation is not implied.

2. Repetitive Rating : Pulse width limited by maximum junction temperature

3. $L = 26.9\text{mH}$, $I_{AS} = 4.4\text{A}$, $V_{DD} = 50\text{V}$, $R_G = 25\ \Omega$, Starting $T_J = 25^\circ\text{C}$

4. $I_{SD} \leq 4.4\text{A}$, $di/dt \leq 200\text{A}/\mu\text{s}$, $V_{DD} \leq BV_{DSS}$, Starting $T_J = 25^\circ\text{C}$

■ THERMAL DATA

PARAMETER		SYMBOL	RATINGS	UNIT
Junction to Ambient	TO-220F/TO-220F1	θ_{JA}	62.5	$^\circ\text{C}/\text{W}$
	TO-251		110	
Junction to Case	TO-220F/TO-220F1	θ_{Jc}	3.47	$^\circ\text{C}/\text{W}$
	TO-251		2.55	

■ ELECTRICAL CHARACTERISTICS ($T_A = 25^\circ\text{C}$, unless otherwise specified)

PARAMETER	SYMBOL	TEST CONDITIONS	MIN	TYP	MAX	UNIT
OFF CHARACTERISTICS						
Drain-Source Breakdown Voltage	BV_{DSS}	$V_{GS} = 0\text{V}$, $I_D = 250\ \mu\text{A}$	700			V
Drain-Source Leakage Current	I_{DSS}	$V_{DS} = 700\text{V}$, $V_{GS} = 0\text{V}$			10	μA
Gate-Source Leakage Current	Forward	I_{GSS}			100	nA
	Reverse				$V_{GS} = -30\text{V}$, $V_{DS} = 0\text{V}$	
Breakdown Voltage Temperature Coefficient	$\Delta BV_{DSS}/\Delta T_J$	$I_D = 250\ \mu\text{A}$, Referenced to 25°C		0.6		$\text{V}/^\circ\text{C}$
ON CHARACTERISTICS						
Gate Threshold Voltage	$V_{GS(TH)}$	$V_{DS} = V_{GS}$, $I_D = 250\ \mu\text{A}$	2.0		4.0	V
Static Drain-Source On-State Resistance	$R_{DS(ON)}$	$V_{GS} = 10\text{V}$, $I_D = 2.2\text{A}$		2.6	2.8	Ω
DYNAMIC CHARACTERISTICS						
Input Capacitance	C_{ISS}	$V_{DS} = 25\text{V}$, $V_{GS} = 0\text{V}$, $f = 1\text{MHz}$		520	670	pF
Output Capacitance	C_{OSS}			70	90	pF
Reverse Transfer Capacitance	C_{RSS}			8	11	pF
SWITCHING CHARACTERISTICS						
Turn-On Delay Time	$t_{D(ON)}$	$V_{DD} = 350\text{V}$, $I_D = 4.4\text{A}$, $R_G = 25\ \Omega$ (Note 1, 2)		13	35	ns
Turn-On Rise Time	t_R			45	100	ns
Turn-Off Delay Time	$t_{D(OFF)}$			25	60	ns
Turn-Off Fall Time	t_F			35	80	ns
Total Gate Charge	Q_G	$V_{DS} = 560\text{V}$, $I_D = 4.4\text{A}$, $V_{GS} = 10\text{V}$ (Note 1, 2)		15	20	nC
Gate-Source Charge	Q_{GS}			3.4		nC
Gate-Drain Charge	Q_{GD}			7.1		nC

■ ELECTRICAL CHARACTERISTICS(Cont.)

PARAMETER	SYMBOL	TEST CONDITIONS	MIN	TYP	MAX	UNIT
SOURCE- DRAIN DIODE RATINGS AND CHARACTERISTICS						
Drain-Source Diode Forward Voltage	V_{SD}	$V_{GS} = 0\text{ V}, I_S = 4.4\text{ A}$			1.4	V
Maximum Continuous Drain-Source Diode Forward Current	I_S				4.4	A
Maximum Pulsed Drain-Source Diode Forward Current	I_{SM}				17.6	A
Reverse Recovery Time	t_{rr}	$V_{GS} = 0\text{ V}, I_S = 4.4\text{ A},$		250		ns
Reverse Recovery Charge	Q_{RR}	$di/dt = 100\text{ A}/\mu\text{s}$ (Note 1)		1.5		μC

Notes: 1. Pulse Test: Pulse width $\leq 300\mu\text{s}$, Duty cycle $\leq 2\%$
 2. Essentially independent of operating temperature

■ TEST CIRCUITS AND WAVEFORMS

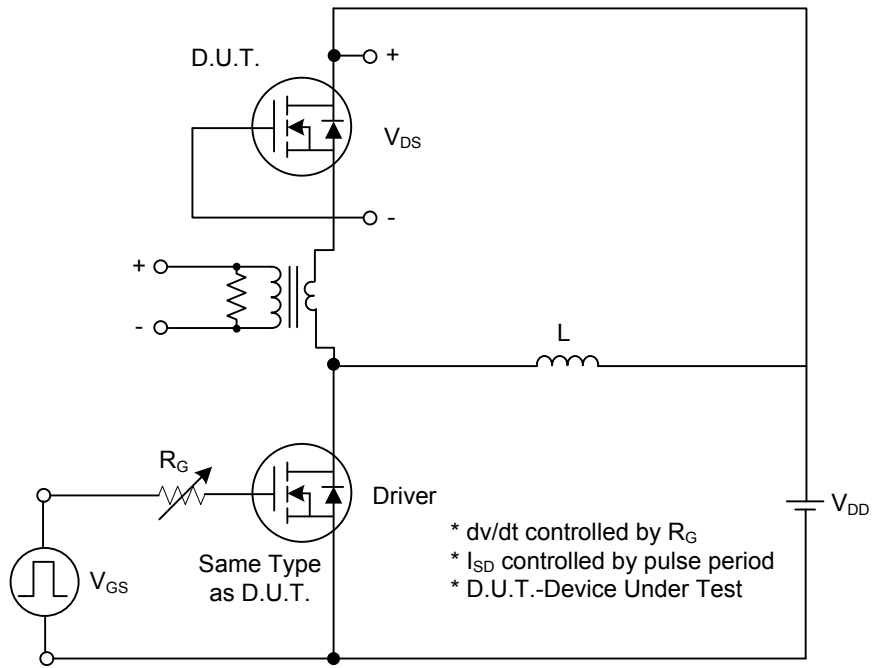

Peak Diode Recovery dv/dt Test Circuit

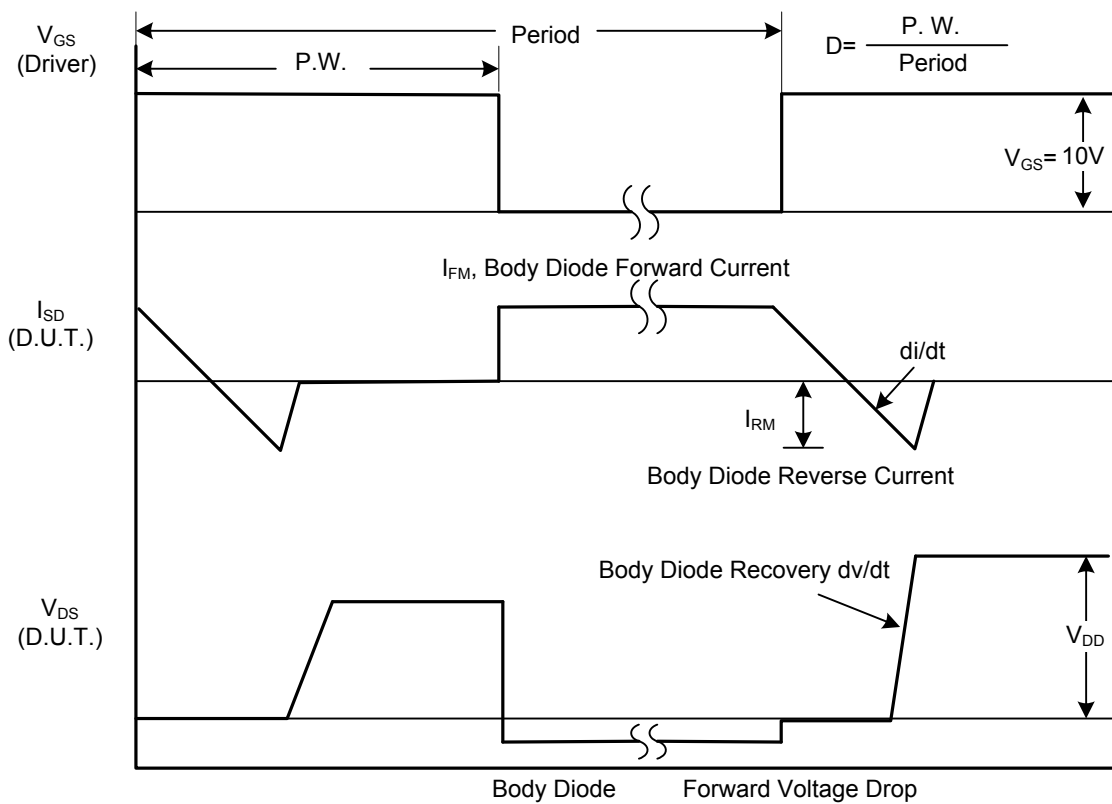

Peak Diode Recovery dv/dt Waveforms

■ TEST CIRCUITS AND WAVEFORMS (Cont.)

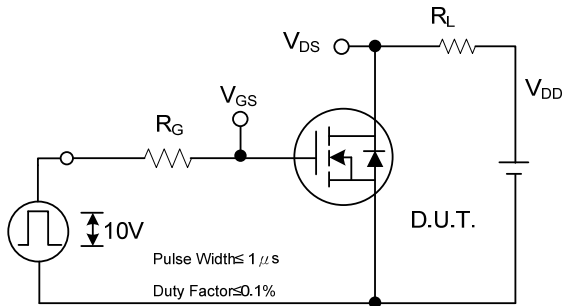

Switching Test Circuit

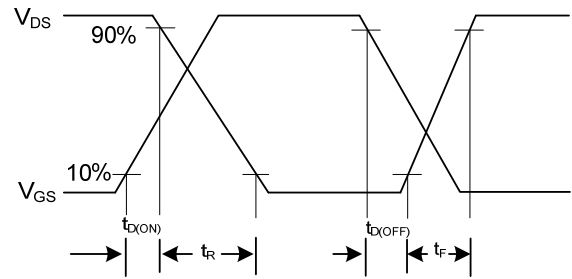

Switching Waveforms

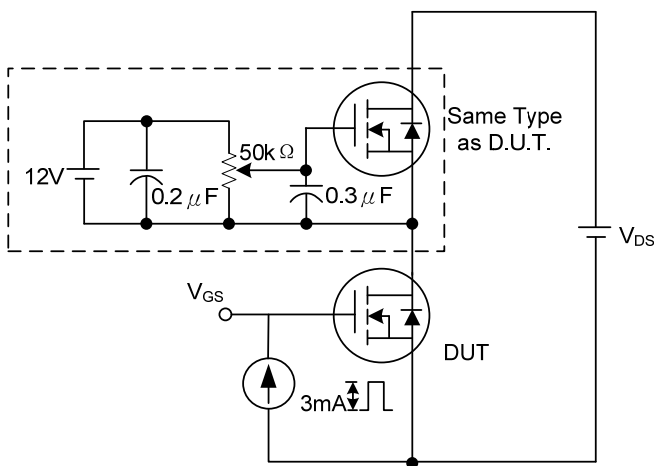

Gate Charge Test Circuit

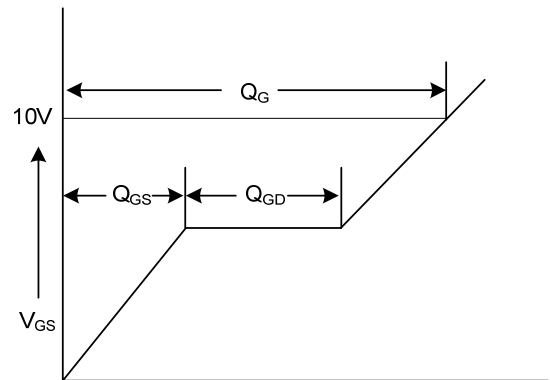

Gate Charge Waveform

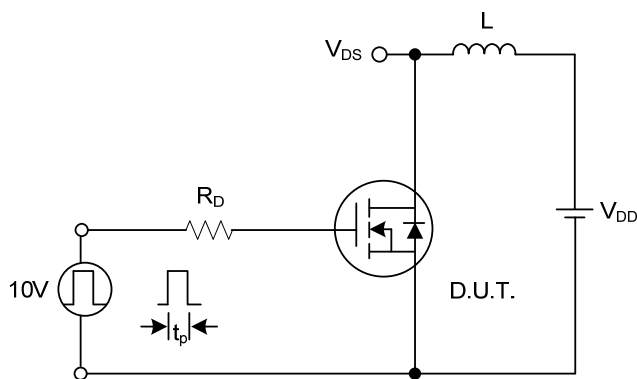

Unclamped Inductive Switching Test Circuit

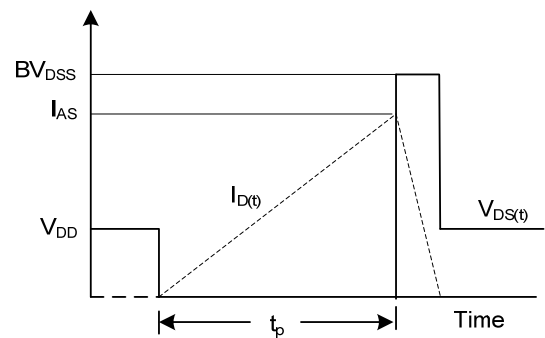

Unclamped Inductive Switching Waveforms

■ TYPICAL CHARACTERISTICS

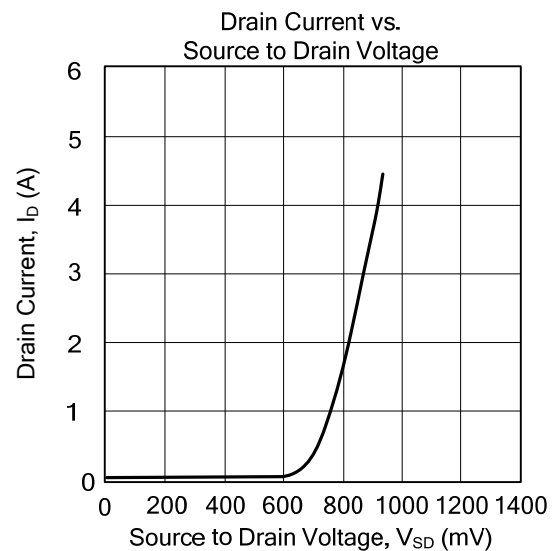
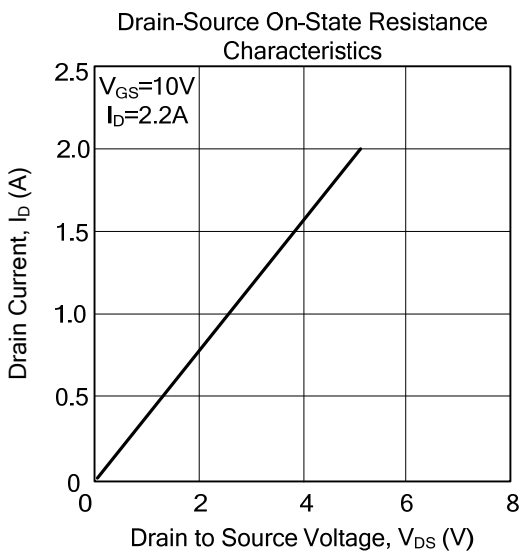
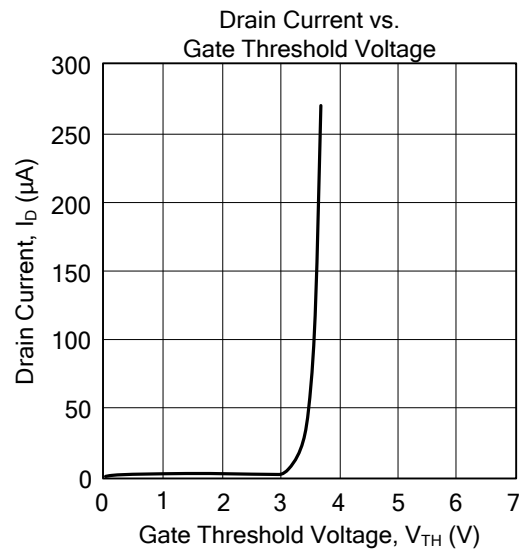
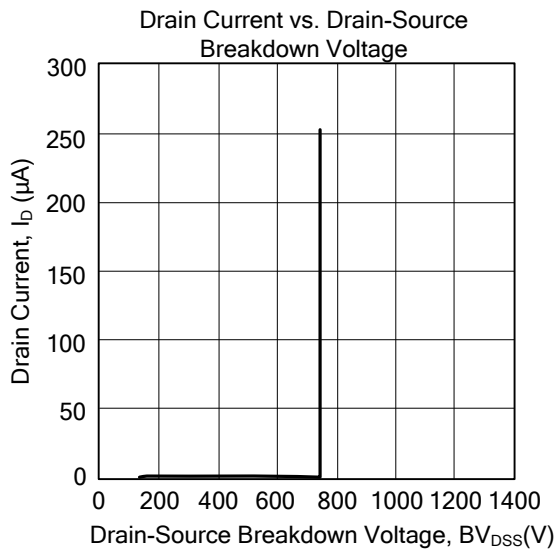

UTC assumes no responsibility for equipment failures that result from using products at values that exceed, even momentarily, rated values (such as maximum ratings, operating condition ranges, or other parameters) listed in products specifications of any and all UTC products described or contained herein. UTC products are not designed for use in life support appliances, devices or systems where malfunction of these products can be reasonably expected to result in personal injury. Reproduction in whole or in part is prohibited without the prior written consent of the copyright owner. The information presented in this document does not form part of any quotation or contract, is believed to be accurate and reliable and may be changed without notice.