

HIGH CURRENT ADJUSTABLE VOLTAGE REGULATOR BL317

DESCRIPTION

The BL317 is an adjustable 3-terminal positive voltage regulator, designed to supply 1A of output current with voltage adjustable from 1.3V ~ 35V.

FEATURES

- Typical 1% Output Voltage Tolerance
- Output voltage adjustable from 1.3V ~35V
- Output current in excess of 1A
- Internal short circuit protection
- Internal over temperature protection
- Output transistor safe area compensation

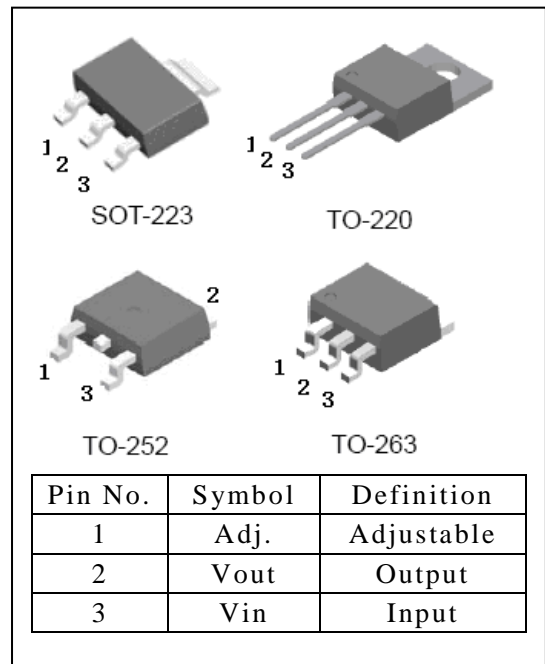

APPLICATIONS

- PC Motherboard
- LCD Monitor
- Graphic Card
- DVD Player
- Network Interface Card/Switch
- Telecom Equipment
- Printer and other Peripheral Equipment

BLOCK DIAGRAM

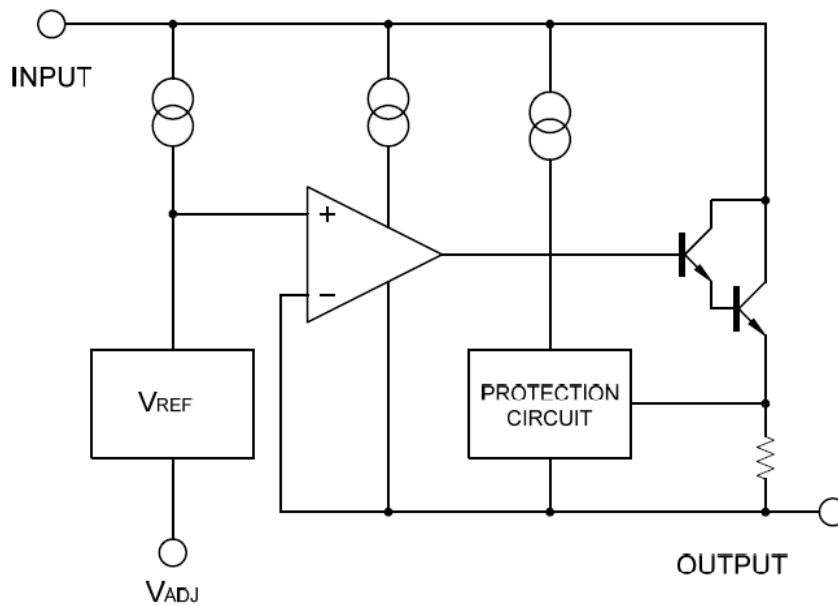

ABSOLUTE MAXIMUM RATINGS ($T_a=25^\circ\text{C}$) *

Characteristic	Symbol	Min.	Max.	Unit
Input - Output Voltage Difference	$V_{in}-V_{out}$		37	V
Power Dissipation	P_d	Internal limited		
Maximum junction temperature	T_J		150	$^\circ\text{C}$
Storage temperature	T_S	-40	150	$^\circ\text{C}$
Lead temperature (soldering, 10sec)	T_{LEAD}		260	$^\circ\text{C}$
ESD (human body model)	ESD		4000	V

*: Absolute maximum ratings are stress ratings only and functional device operation is not implied. The device could be damaged beyond Absolute maximum ratings.

ELECTRICAL CHARACTERISTICS ($V_{IN}-V_{OUT}=5V$, $I_{OUT}=10mA$, $T_a=25^{\circ}C$, unless otherwise specified.) *

Characteristics	Test conditions	Symbol	Min.	Typ.	Max.	Unit
Reference voltage	$10mA \leq I_{OUT} \leq 1A$ $3V \leq (V_{IN}-V_{OUT}) \leq 37V$ $PD \leq 20W$	V_{REF}	1.20	1.25	1.30	V
Line regulation	$3V \leq V_{IN}-V_{OUT} \leq 37V$	S_V		0.01	0.04	%/V
Load regulation	$0mA \leq I_{OUT} \leq 1A$	S_i		0.2	0.4	%
Adjust pin current		I_{adj}		50	100	μA
Adjust pin current change	$3V \leq V_{IN}-V_{OUT} \leq 37V$, $10mA \leq I_{OUT} \leq 1A$, $PD \leq 20W$	ΔI_{adj}		0.2	5.0	μA
Minimum load current	$V_{IN}-V_{OUT}=37V$	I_{Lmin}		3.5	10.0	mA
Ripple rejection	$f=120Hz$, $C_{OUT}=1\mu F$ tantalum, $(V_{IN}-V_{OUT})=3V$, $I_{OUT}=1A$	RR	60	75		dB
Temperature stability	$T_{MIN} \leq T_J \leq T_{MAX}$			0.7		%
RMS output noise (% of V_{OUT})	$T_a=25^{\circ}C$, $10Hz \leq f \leq 10kHz$	en		0.003		%
Thermal resistance, Junction to case	SOT-223 TO-252 TO-220 TO-263	θ_{JC}		23 12 5 5		$^{\circ}C/W$
Thermal resistance, Junction to Ambient	SOT-223 TO-252 TO-220 TO-263	θ_{JA}		165 112 54 64		$^{\circ}C/W$
Thermal shutdown hysteresis		Thys		25		$^{\circ}C$

*: Maximum Power Dissipation is Package Type and Case Temperature dependent.

APPLICATION CIRCUIT

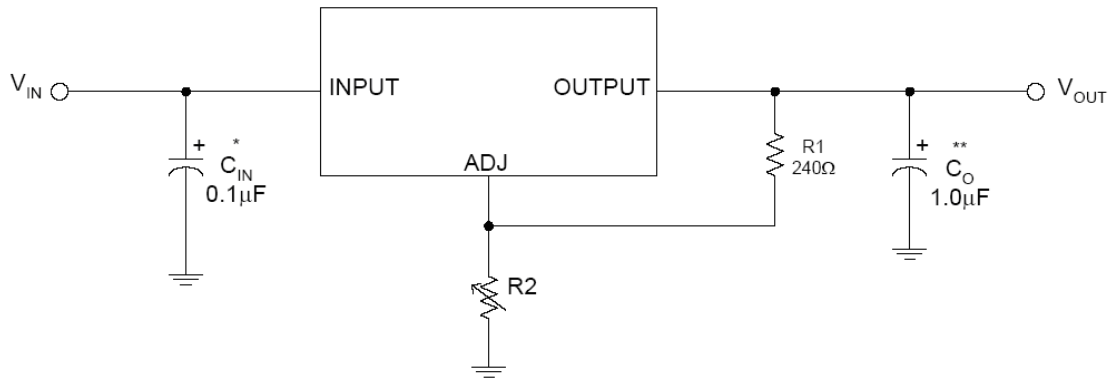

* = C_{IN} is required if the regulator is located near power supply filter.

** = C_O is needed for stability and it improves transient response.

$$V_{OUT} = V_{REF} \times (1 + R2/R1) + I_{ADJ} \times R2$$

Since I_{ADJ} is controlled to less than $100\mu A$, the error associated with this term is negligible in most applications.

CHARACTERISTICS CURVES

Load Regulation vs. temperature

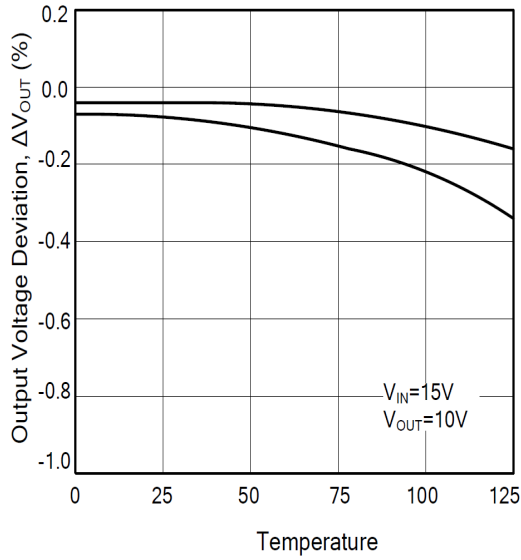

Adjustment Current vs. Temperature

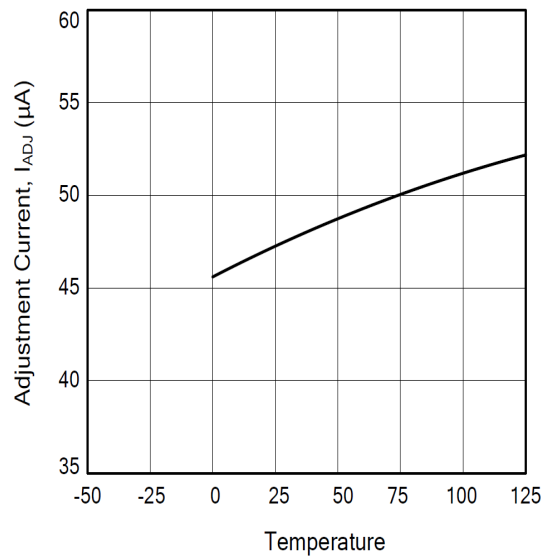

Current Limit

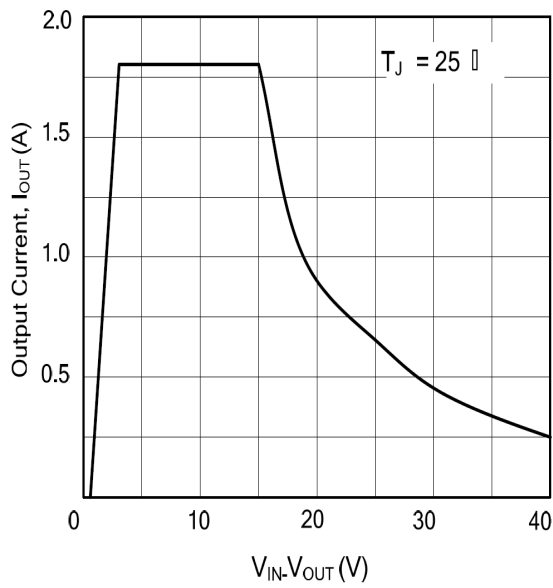

Minimum Operating Current

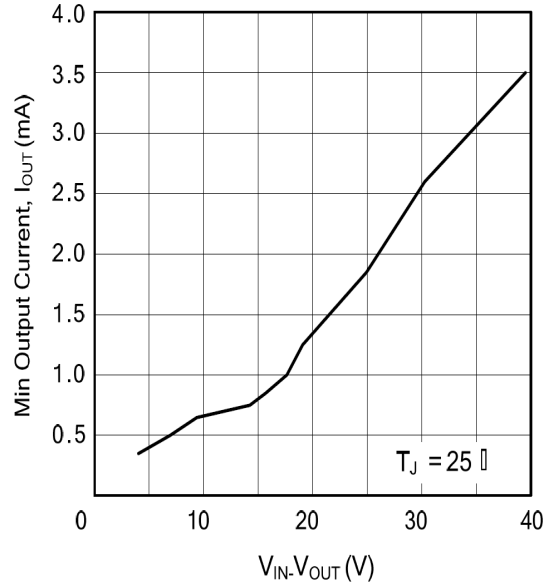

OUTLINE DRAWING

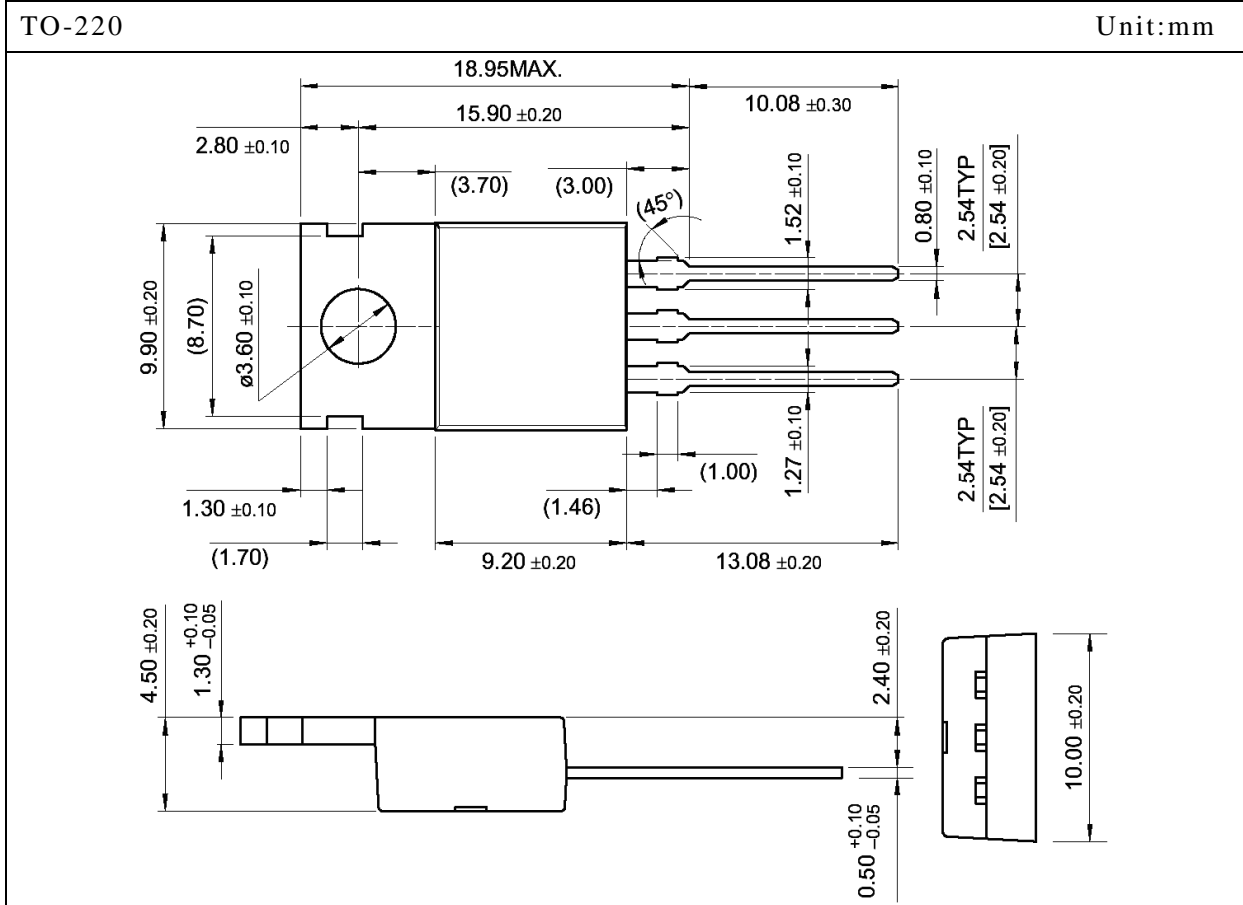
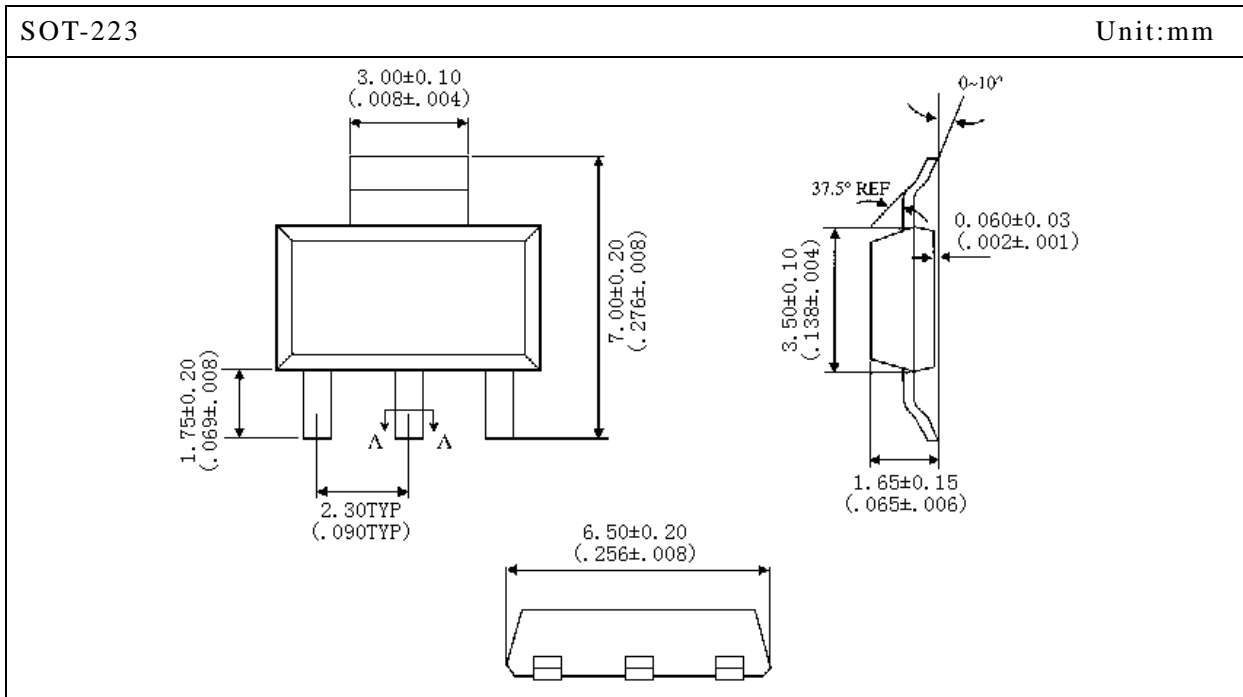

TO-252

Unit:mm

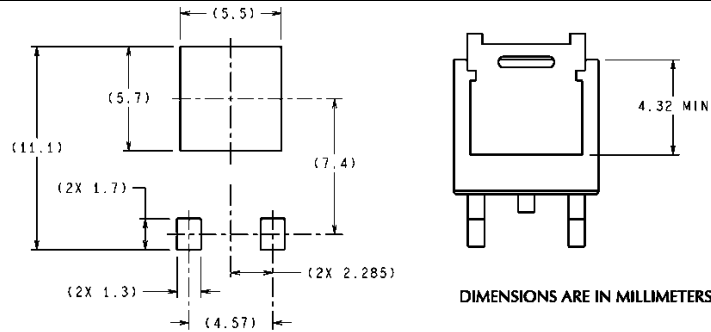

LAND PATTERN RECOMMENDATION

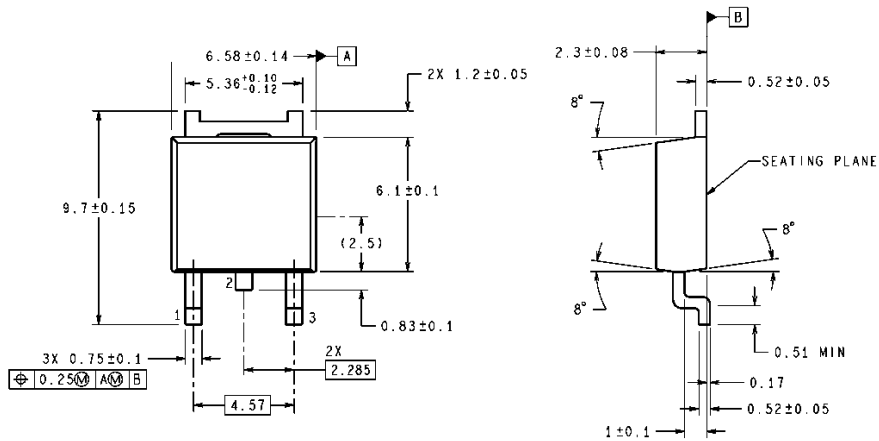

TO-263

Unit:mm

