



**2SA1774**

**PNP EPITAXIAL SILICON TRANSISTOR**

**GENERAL PURPOSE TRANSISTOR**

■ FEATURES

- \* Excellent  $h_{FE}$  linearity
- \* Complements the UTC **2SC4617**

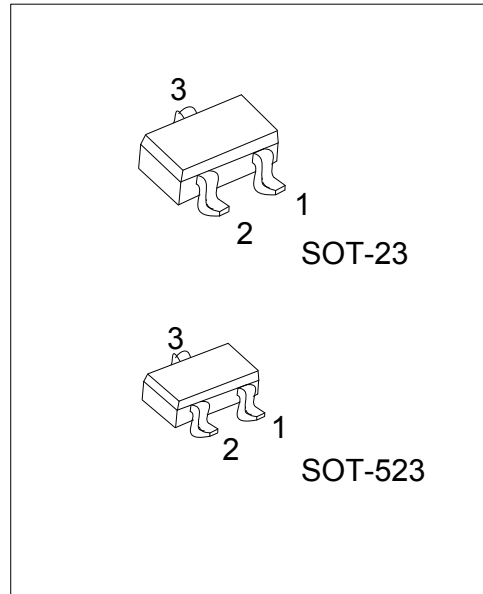

■ ORDERING INFORMATION

Ordering Number		Package	Pin Assignment			Packing
Lead Free	Halogen Free		1	2	3	
2SA1774L-x-AE3-R	2SA1774G-x-AE3-R	SOT-23	E	B	C	Tape Reel
2SA1774L-x-AN3-R	2SA1774G-x-AN3-R	SOT-523	E	B	C	Tape Reel

Note: Pin Assignment: E: EMITTER B: BASE C: COLLECTOR

<p>2SA1774L-x-AE3-R</p> <p>(1)Packing Type (2)Package Type (3)Rank (3)Lead Free</p>	<p>(1) R: Tape Reel (2) AE3: SOT-23, AN3: SOT-523 (3) x: refer to Classification of <math>h_{FE}</math> (4) G:Halogen Free, L: Lead Free</p>
---	--

■ MARKING

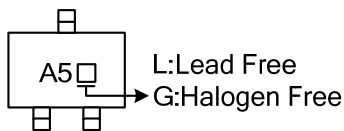

■ ABSOLUTE MAXIMUM RATING (T<sub>A</sub>=25°C)

PARAMETER		SYMBOL	RATINGS	UNIT
Collector-Base Voltage		V <sub>CBO</sub>	-60	V
Collector-Emitter Voltage		V <sub>CEO</sub>	-50	V
Emitter-Base Voltage		V <sub>EBO</sub>	-6	V
Collector Current		I <sub>C</sub>	-0.15	A
Collector Power Dissipation	SOT-23	P <sub>C</sub>	0.22	W
	SOT-523		0.15	
Junction Temperature		T <sub>J</sub>	150	°C
Storage Temperature		T <sub>STG</sub>	-55 ~ +150	°C

Note 1. Absolute maximum ratings are those values beyond which the device could be permanently damaged.

Absolute maximum ratings are stress ratings only and functional device operation is not implied.

2. The device is guaranteed to meet performance specification within 0°C~70°C operating temperature range and assured by design from -20°C~85°C.

■ ELECTRICAL CHARACTERISTICS (T<sub>A</sub>=25°C, unless otherwise specified.)

PARAMETER	SYMBOL	TEST CONDITIONS	MIN	TYP	MAX	UNIT
Collector-Base Breakdown Voltage	BV <sub>CBO</sub>	I <sub>C</sub> = -50μA	-60			V
Collector-Emitter Breakdown Voltage	BV <sub>CEO</sub>	I <sub>C</sub> = -1mA	-50			V
Emitter-Base Breakdown Voltage	BV <sub>EBO</sub>	I <sub>E</sub> = -50μA	-6			V
Collector Cutoff Current	I <sub>CBO</sub>	V <sub>CB</sub> = -60V			-0.1	μA
Emitter Cutoff Current	I <sub>EBO</sub>	V <sub>EB</sub> = -6V			-0.1	μA
DC Current Transfer Ratio	h <sub>FE</sub>	V <sub>CE</sub> = -6V, I <sub>C</sub> = -1mA	120		560	
Collector-Emitter Saturation Voltage	V <sub>CE(SAT)</sub>	I <sub>C</sub> = -50mA, I <sub>B</sub> = -5mA			-0.5	V
Transition Frequency	f <sub>T</sub>	V <sub>CE</sub> = -12V, I <sub>E</sub> = 2mA, f = 100MHz		140		MHz
Output Capacitance	C <sub>OB</sub>	V <sub>CB</sub> = -12V, I <sub>E</sub> = 0A, f = 1MHz		4.0	5.0	pF

■ CLASSIFICATION OF h<sub>FE1</sub>

RANK	Q	R	S
Range	120 ~ 270	180 ~ 390	270 ~ 560

## TYPICAL CHARACTERISTICS

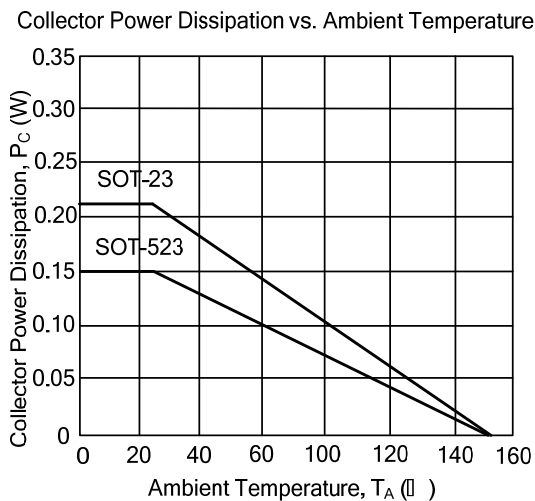
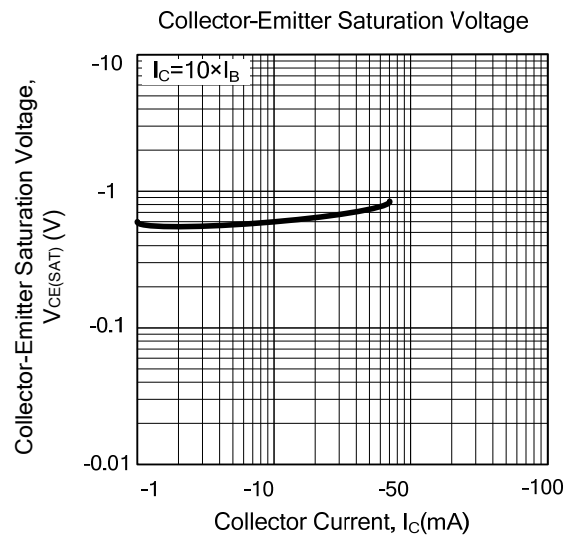
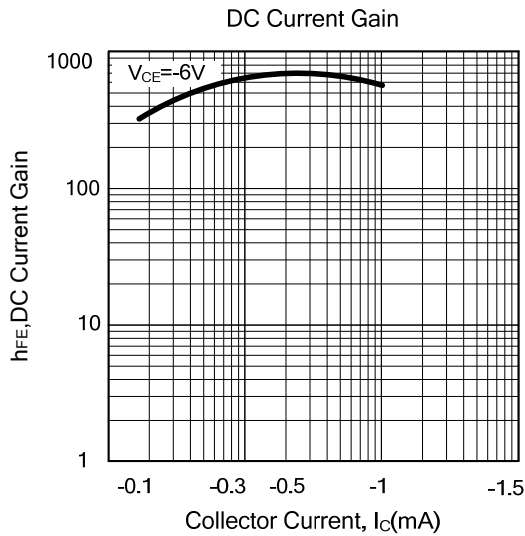

UTC assumes no responsibility for equipment failures that result from using products at values that exceed, even momentarily, rated values (such as maximum ratings, operating condition ranges, or other parameters) listed in products specifications of any and all UTC products described or contained herein. UTC products are not designed for use in life support appliances, devices or systems where malfunction of these products can be reasonably expected to result in personal injury. Reproduction in whole or in part is prohibited without the prior written consent of the copyright owner. The information presented in this document does not form part of any quotation or contract, is believed to be accurate and reliable and may be changed without notice.