

RAL1A ... RAL1M

Fast Switching Surface Mount Controlled Avalanche Rectifiers Schnelle SMD-Gleichrichter mit kontrolliertem Durchbruchverhalten

Version 2010-01-14

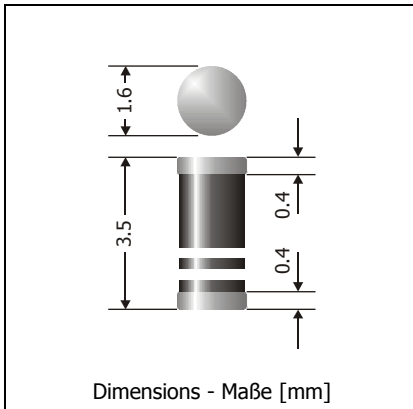

Nominal current – Nennstrom	1 A
Repetitive peak reverse voltage Periodische Spitzensperrspannung	50...1000 V
Plastic case MiniMELF Kunststoffgehäuse MiniMELF	DO-213AA
Weight approx. – Gewicht ca.	0.04 g
Plastic material has UL classification 94V-0 Gehäusematerial UL94V-0 klassifiziert	
Standard packaging taped and reeled Standard Lieferform gegurtet auf Rolle	

Marking:	1. red ring denotes "cathode" and "fast switching rectifier family" 2. colored ring denotes "repetitive peak reverse voltage" (see below)
Kennzeichnung:	1. roter Ring kennzeichnet "Kathode" und "schnelle Gleichrichter" 2. farbiger Ring kennzeichnet "Periodische Spitzensperrspannung" (siehe unten)

Maximum ratings

Grenzwerte

Type Typ	Repetitive peak reverse voltage Periodische Spitzensperrspannung V_{RRM} [V]	Reverse avalanche breakdown voltage Sperrspannung im Durchbruch V_{RSM} [V] ¹⁾	2. Cathode ring 2. Kathodenring
RAL1A	50	> 75	grey / grau
RAL1B	100	> 150	red / rot
RAL1D	200	> 250	orange / orange
RAL1G	400	> 450	yellow / gelb
RAL1J	600	> 650	green / grün
RAL1K	800	> 850	blue / blau
RAL1M	1000	> 1100	violet / violett

Max. average forward rectified current, R-load Dauergrenzstrom in Einwegschaltung mit R-Last	$T_A = 75^\circ\text{C}$	I_{FAV}	1 A ²⁾
Peak forward surge current, 50/60 Hz half sine-wave Stoßstrom für eine 50/60 Hz Sinus-Halbwelle	$T_A = 25^\circ\text{C}$	I_{FSM}	22/25 A
Rating for fusing, $t < 10$ ms Grenzlastintegral, $t < 10$ ms	$T_A = 25^\circ\text{C}$	i^2t	2.5 A ² s
Non-repetitive peak reverse avalanche energy Einmalige Impulsenergie in Sperr-Richtung	$I_{RSM} = 1$ mA $T_A = 25^\circ\text{C}$	E_{RSM}	20 mJ
Junction temperature – Sperrschichttemperatur		T_j	-50...+175°C
Storage temperature – Lagerungstemperatur		T_s	-50...+175°C

1 $I_{RSM} = 1$ mA, $T_A = 25^\circ\text{C}$

2 Mounted on P.C. board with 25 mm² copper pads at each terminal
Montage auf Leiterplatte mit 25 mm² Kupferbelag (Löt-pad) an jedem Anschluss

Characteristics
Kennwerte

Forward voltage Durchlass-Spannung	$T_j = 25^\circ\text{C}$	$I_F = 1\text{ A}$	V_F	< 1.3 V	
Leakage current Sperrstrom	$T_j = 25^\circ\text{C}$	$V_R = V_{RRM}$	I_R	< 3 μA	
	$T_j = 125^\circ\text{C}$	$V_R = V_{RRM}$	I_R	< 50 μA	
Reverse recovery time Sperrverzugszeit	$I_F = 0.5\text{ A}$ through/über $I_R = 1\text{ A}$ to $I_R = 0.25\text{ A}$	RAL1A...G	t_{rr}	< 150 ns	
		RAL1J	t_{rr}	< 250 ns	
		RAL1K...M	t_{rr}	< 500 ns	
Thermal resistance junction to ambient air Wärmewiderstand Sperrschicht – umgebende Luft				R_{thA}	< 75 K/W ¹⁾
Thermal resistance junction to terminal Wärmewiderstand Sperrschicht – Anschluss				R_{thT}	< 40 K/W

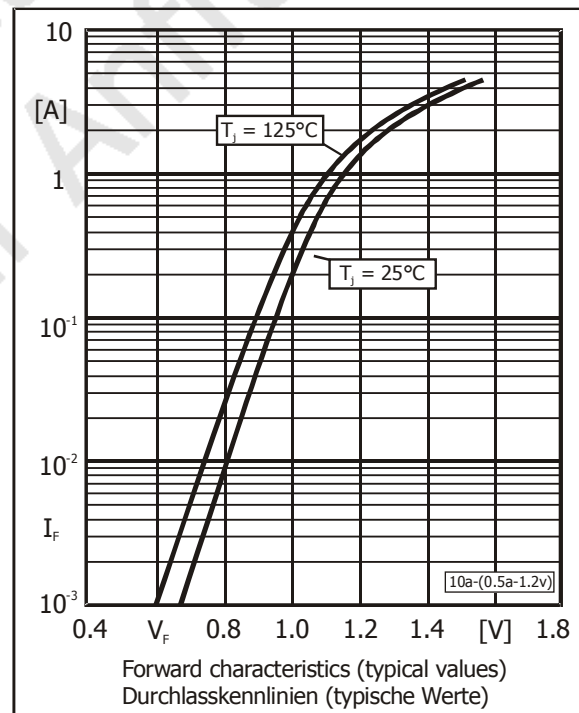
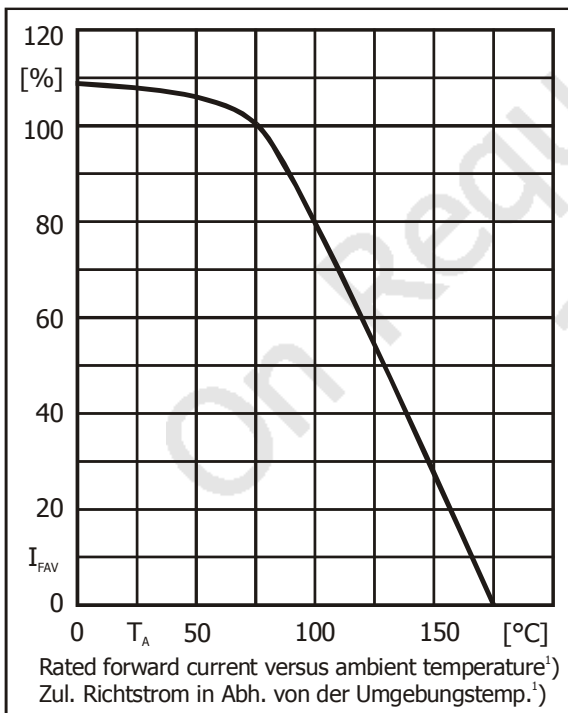

1 Mounted on P.C. board with 25 mm² copper pads at each terminal
 Montage auf Leiterplatte mit 25 mm² Kupferbelag (Löt-pad) an jedem Anschluss