

MECHANICAL DATA

Dimensions in mm (inches)

PNP SILICON TRANSISTOR

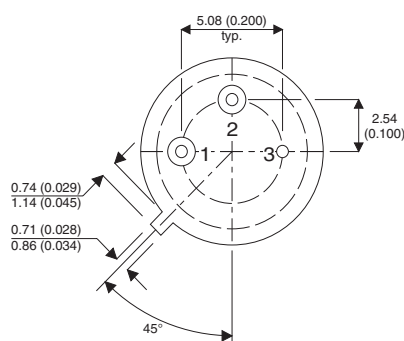
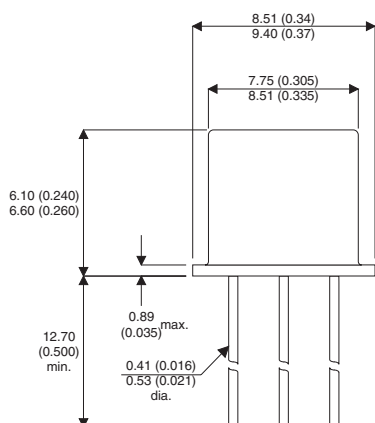

TO-39 (TO-205AD) METAL PACKAGE

Underside View

PIN 1 – Emitter PIN 2 – Base PIN 3 – Collector

FEATURES

- High Voltage Switching
- Low Power Amplifier Applications
- Hermetic TO39 Package

APPLICATIONS:

- General Purpose
- High Speed Saturated Switching

ABSOLUTE MAXIMUM RATINGS ($T_{case} = 25^{\circ}C$ unless otherwise stated)

V_{CEO}	Collector – Emitter Voltage	-140V
V_{CBO}	Collector – Base Voltage	-140V
V_{EBO}	Emitter – Base Voltage	-5V
I_C	Collector Current	-1A
P_D	Total Device Dissipation @ $T_A = 25^{\circ}C$	1W
	Derate above $25^{\circ}C$	5.71mW/ $^{\circ}C$
P_D	Total Device Dissipation @ $T_C = 25^{\circ}C$	5W
	Derate above $25^{\circ}C$	28.6mW / $^{\circ}C$
T_J, T_{STG}	Operating and Storage Junction Temperature Range	-65 to +200 $^{\circ}C$

Semelab Plc reserves the right to change test conditions, parameter limits and package dimensions without notice. Information furnished by Semelab is believed to be both accurate and reliable at the time of going to press. However Semelab assumes no responsibility for any errors or omissions discovered in its use. Semelab encourages customers to verify that datasheets are current before placing orders.

ELECTRICAL CHARACTERISTICS ($T_A = 25^\circ\text{C}$ unless otherwise stated)

Parameter	Test Conditions	Min.	Typ.	Max.	Unit
OFF CHARACTERISTICS					
BV_{CEO}	Collector–Emitter Breakdown Voltage ¹	$I_C = -10\text{mA}$ $I_B = 0$	-140		V
BV_{CBO}	Collector – Base Breakdown Voltage ¹	$I_C = -100\mu\text{A}$ $I_E = 0$	-140		
BV_{EBO}	Emitter – Base Breakdown Voltage ¹	$I_C = 0$ $I_E = -10\mu\text{A}$	-5.0		
I_{EBO}	Emitter Cut-off Current	$V_{BE} = -3.0\text{V}$ $I_C = 0$		-50	nA
I_{CBO}	Collector Cut-off Current	$V_{CB} = -100\text{V}$ $I_E = 0$		-100	
ON CHARACTERISTICS					
h_{FE}	DC Current Gain ¹	$I_C = -0.1\text{mA}$ $V_{CE} = -10\text{V}$	80		–
		$I_C = -1.0\text{mA}$ $V_{CE} = -10\text{V}$	90		
		$I_C = -10\text{mA}$ $V_{CE} = -10\text{V}$	100		
		$I_C = -50\text{mA}$ $V_{CE} = -10\text{V}$	100	300	
		$I_C = -150\text{mA}$ $V_{CE} = -10\text{V}$	50		
$V_{CE(sat)}$	Collector – Emitter Saturation Voltage ¹	$I_C = -10\text{mA}$ $I_B = -1.0\text{mA}$		-0.3	V
		$I_C = -50\text{mA}$ $I_B = -5\text{mA}$		-0.5	
$V_{BE(sat)}$	Base – Emitter Saturation Voltage ¹	$I_C = -10\text{mA}$ $I_B = -1.0\text{mA}$		-0.8	V
		$I_C = -50\text{mA}$ $I_B = -5\text{mA}$	-0.65	-0.9	
SMALL SIGNAL CHARACTERISTICS					
f_t	Current Gain Bandwidth Product	$V_{CE} = -30\text{V}$ $I_C = -30\text{mA}$ $f = 100\text{MHz}$	100		MHz
C_{ob}	Output Capacitance	$V_{CB} = -20\text{V}$ $I_E = 0$ $f = 100\text{kHz}$		10	pF
C_{ib}	Input Capacitance	$V_{BE} = 1.0\text{V}$ $I_C = 0$ $f = 1.0\text{MHz}$		75	pF
h_{ie}	Input Impedance		200	1200	Ω
h_{re}	Voltage Feedback Ratio	$V_{CE} = -10\text{V}$ $I_C = -10\text{mA}$		3.0	$\times 10^{-4}$
h_{fe}	Small Signal Current Gain	$f = 1.0\text{kHz}$	80	320	—
h_{oe}	Output Admittance			200	μmhos
NF	Noise Figure	$V_{CE} = -10\text{V}$ $I_C = -0.5\text{mA}$ $R_S = 1.0\text{K}\Omega$ $f = 1.0\text{kHz}$		3.0	dB
SWITCHING CHARACTERISTICS					
t_{on}	Turn–On Time	$V_{CC} = -100\text{V}$ $V_{BE} = 4.0\text{V}$		400	ns
t_{off}	Turn–Off Time	$I_C = -50\text{mA}$ $I_{B1} = I_{B2} = -5\text{mA}$		600	

1) Pulse test : Pulse Width < 300 μs ,Duty Cycle < 2%

Semelab Plc reserves the right to change test conditions, parameter limits and package dimensions without notice. Information furnished by Semelab is believed to be both accurate and reliable at the time of going to press. However Semelab assumes no responsibility for any errors or omissions discovered in its use. Semelab encourages customers to verify that datasheets are current before placing orders.

Semelab plc. Telephone +44(0)1455 556565. Fax +44(0)1455 552612.

E-mail: sales@semelab.co.uk Website: <http://www.semelab.co.uk>

Document Number 5943

Issue 2