



# PS200~PS2010

## PLASTIC SILICON RECTIFIER

**VOLTAGE** 50 to 1000 Volts **CURRENT** 2.0 Amperes

**DO-15** Unit: inch(mm)

### FEATURES

- Low cost
- High current capability
- Plastic package has Underwriters Laboratories Flammability Classification 94V-O utilizing Flame Retardant Epoxy Molding Compound.
- Exceeds environmental standards of MIL-S-19500/228
- Low leakage
- In compliance with EU RoHS 2002/95/EC directives

### MECHANICAL DATA

- Case: Molded plastic, DO-15
- Terminals: Axial leads, solderable to MIL-STD-750, Method 2026
- Polarity: Color Band denotes cathode end
- Mounting Position: Any
- Weight: 0.014 ounce, 0.397 gram

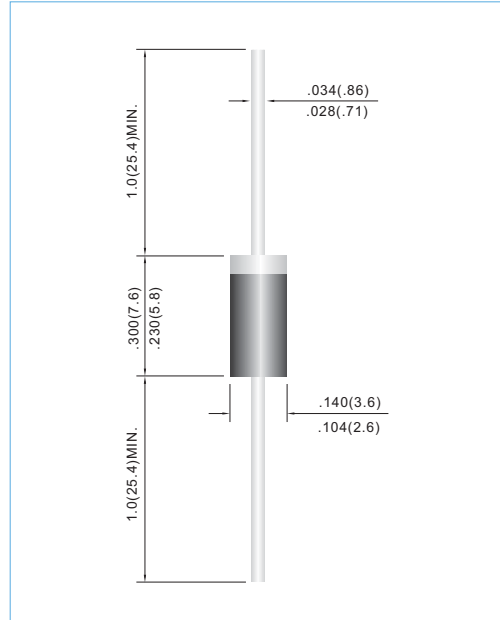

## MAXIMUM RATINGS AND ELECTRICAL CHARACTERISTICS

Ratings at 25°C ambient temperature unless otherwise specified.

Resistive or inductive load, 60Hz.

PARAMETER	SYMBOL	PS200	PS201	PS202	PS204	PS206	PS208	PS2010	UNITS
Maximum Recurrent Peak Reverse Voltage	$V_{RRM}$	50	100	200	400	600	800	1000	V
Maximum RMS Voltage	$V_{RMS}$	35	70	140	280	420	560	700	V
Maximum DC Blocking Voltage	$V_{DC}$	50	100	200	400	600	800	1000	V
Maximum Average Forward Current .375" (9.5mm) lead length at $T_A = 60^\circ\text{C}$	$I_{F(AV)}$	2.0							A
Peak Forward Surge Current : 8.3ms single half sine-wave superimposed on rated load (JEDEC method)	$I_{FSM}$	70							A
Maximum Forward Voltage at 2.0A	$V_F$	1.1							V
Maximum DC Reverse Current at $T_J = 25^\circ\text{C}$ Rated DC Blocking Voltage $T_J = 100^\circ\text{C}$	$I_R$	5.0 500							$\mu\text{A}$
Typical Junction capacitance (Note 1)	$C_J$	25							pF
Typical Thermal Resistance	$R_{\theta JA}$ $R_{\theta JC}$	70 50							$^\circ\text{C} / \text{W}$
Typical Thermal Resistance (Note 2)	$R_{\theta JL}$	25							$^\circ\text{C} / \text{W}$
Operating Junction and Storage Temperature Range	$T_J, T_{STG}$	-55 to +150							$^\circ\text{C}$

NOTES: 1. Measured at 1 MHz and applied reverse voltage of 4.0 VDC

2. Thermal resistance from junction to ambient and from junction to lead length 0.375" (9.5mm) P.C.B. mounted



# PS200~PS2010

## RATING AND CHARACTERISTIC CURVES

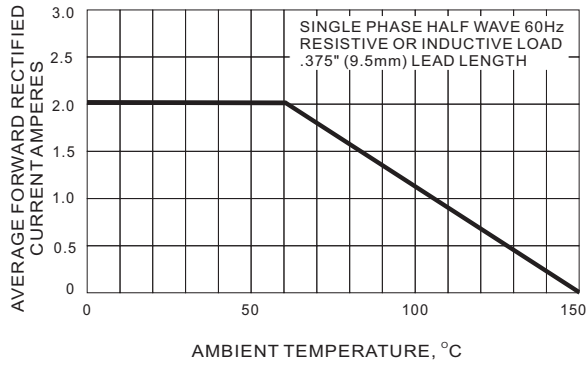

FIG. 1 FORWARD CURRENT DERATING CURVE

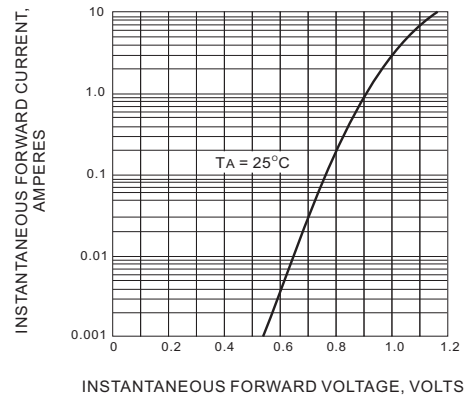

FIG. 2 TYPICAL FORWARD CHARACTERISTICS

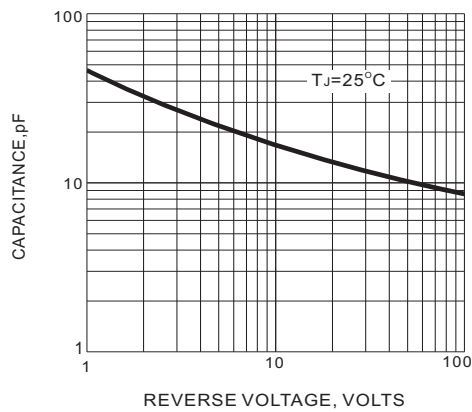

FIG. 3 TYPICAL JUNCTION CAPACITANCE

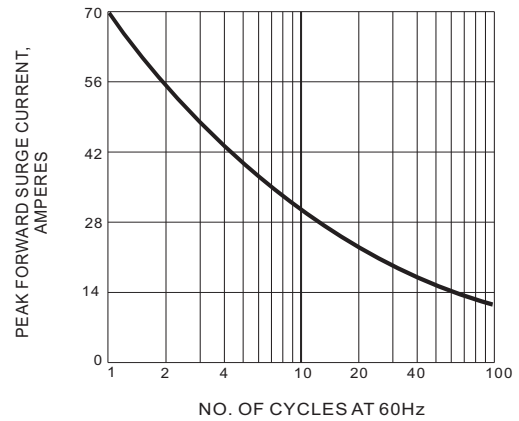

FIG. 4 MAX NON-REPETITIVE SURGE CURRENT

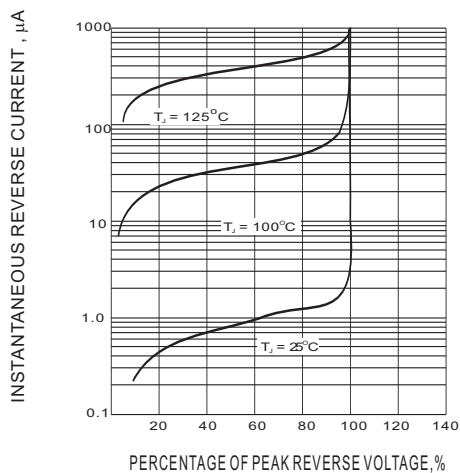

Fig.5-TYPICAL REVERSE CHARACTERISTIC