

### DUAL LOW NOISE OPERATIONAL AMPLIFIER

#### FEATURES

- Internal Frequency Compensation Type.
- Wide Band Range :  $f_T=3\text{MHz}$  (Typ.)
- Suitable Application for Active Filter and Equalizer Amplifier.

#### PIN CONNECTION (TOP VIEW)

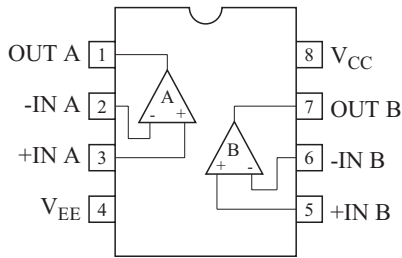

#### MARKING

KIA4558P

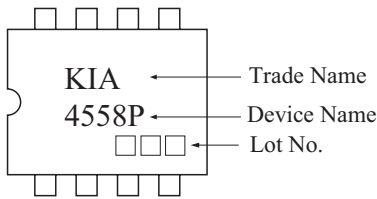

KIA4558F

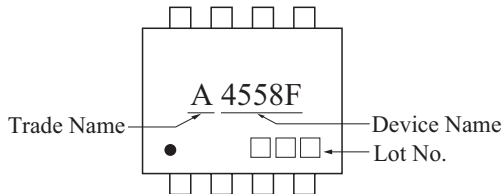

#### MAXIMUM RATINGS (Ta=25 °C)

CHARACTERISTIC	SYMBOL	RATING	UNIT
Supply Voltage	$V_{CC}$	36 or 18	V
	$V_{EE}$	0 or -18	
Differential Input Voltage	$D_{VIN}$	$\pm 30$	V
Input Voltage	$V_{IN}$	$V_{CC}$ $V_{EE}$	V
Power Dissipation	KIA4558P	500	mW
	KIA4558F	240	
Operating Temperature	$T_{opr}$	-40 85	
Storage Temperature	$T_{stg}$	-55 125	

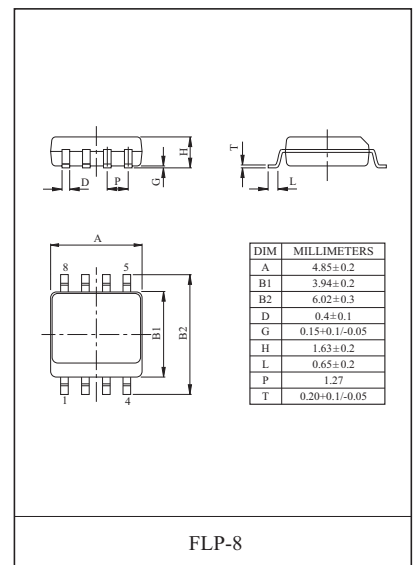
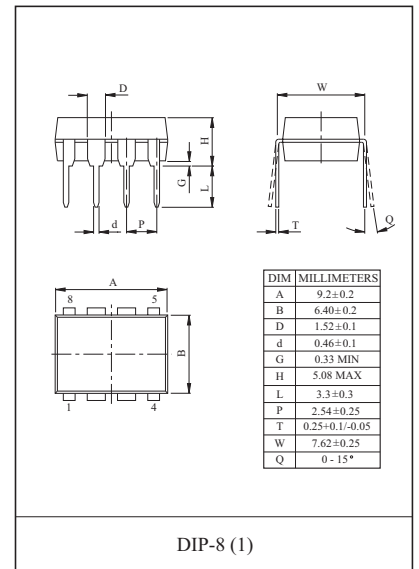
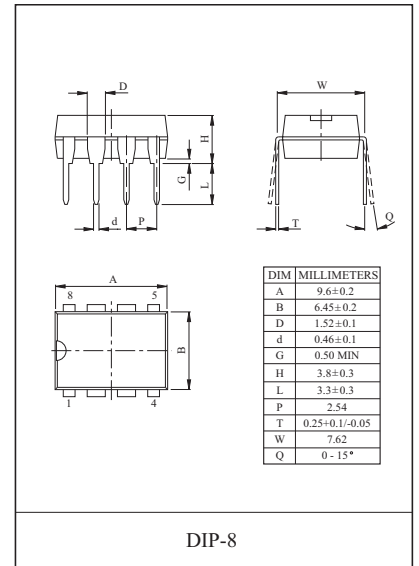

# KIA4558P/F

## EQUIVALENT CIRCUIT

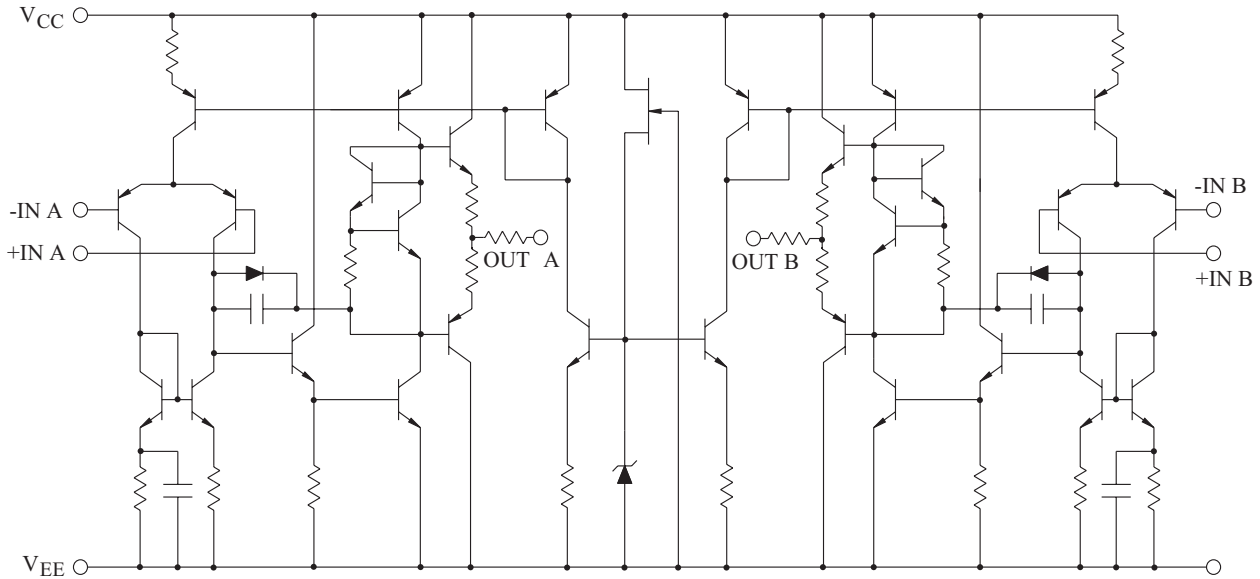

## ELECTRICAL CHARACTERISTICS ( $V_{CC}=15V$ , $V_{EE}=-15$ , $T_a=25$ )

CHARACTERISTIC	SYMBOL	TEST CIRCUIT	TEST CONDITION	Min.	TYP.	MAX.	UNIT
Input Offset Voltage	$V_{IO}$	-	$R_g = 10k$	-	0.5	6	mV
Input Offset Current	$I_{IO}$	-	-	-	5	200	nA
Input Bias Current	$I_I$	-	-	-	60	500	nA
Common Mode Input Voltage	$CMV_{IN}$	-	-	$\pm 12$	$\pm 14$	-	V
Maximum Output Voltage	$V_{OM}$	-	$R_L=10k$	$\pm 12$	$\pm 14$	-	V
	$V_{OMR}$		$R_L=2k$	$\pm 10$	$\pm 13$	-	
Source Current	$I_{source}$	-	-	27	-	-	mA
Sink Current	$I_{sink}$	-	-	27	-	-	mA
Voltage Gain (Open Loop)	$G_V$	-	$V_{OUT} = \pm 10V$ , $R_L=2k$	86	100	-	dB
Common Mode Input Signal Rejection Ratio	CMRR	-	$R_g = 10k$	70	90	-	dB
Supply Voltage Rejection Ratio	SVRR	-	$R_g = 10k$	-	30	150	$\mu V/V$
Slew Rate	SR	-	$G_V=1$ , $R_L=2k$	-	1.0	-	V/ $\mu s$
Unity Gain Cross Frequency	$f_T$	-	Open Loop	-	3.0	-	MHz
Supply Current	$I_{CC}$ , $I_{EE}$	-	-	-	4.0	6.0	mA
Equivalent Input Noise Voltage	$V_{NI}$	-	$R_S=1k$ , $f=30Hz \sim 30kHz$	-	2.5	-	$\mu V_{rms}$

# KIA4558P/F

