

Agilent HPMX-7201 CDMA/AMPS Dual Band Upconverter/VGA/Driver Amplifier

Data Sheet

General Description

The HPMX-7201 upconverter is designed for use in Dual-Band, Dual-Mode PCS-CDMA/AMPS handsets and complements Agilent Technologies's CDMA Chipset solution.

The HPMX-7201 contains an upconverter and RF variable gain driver amplifier for the PCS-CDMA transmit chain. The AMPS transmit chain features an image reject upconverter and a driver amplifier.

The PCS-CDMA transmit chain provides excellent Adjacent Channel Power Rejection and a low noise floor for compliance with TIA98-C requirements. The CDMA driver has a high output power for direct interfacing with CDMA Power Amplifiers and incorporates a switch on the output to support split-band

filtering. The driver is adaptively biased to reduce current consumption and extend battery life. The image reject upconverter on the AMPS transmit chain eliminates the need for a filter between the mixer and the driver amplifier.

The IC operates from a 3V regulated supply, making it ideal for use with a single cell Lithium Ion battery. The Drivers can be directly powered from the battery for enhanced performance. The power down function reduces the supply current to 1 μ A, typical to support gated operation and eliminate the need for a power supply switch.

The HPMX-7201 is fabricated using a 40 GHz Fmax silicon bipolar process and is packaged in a 5x5 mm 32 pin TQFP package.

5x5 mm TQFP-32 Package

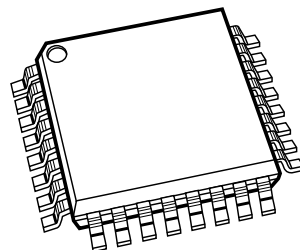

Features

- Dual-Band, Dual-mode operation
- High output power to directly drive the power amplifiers
- 30 dB gain control and adaptive biasing on CDMA driver
- 2.7 to 3.6V operation
- Switched CDMA driver outputs to support split-band filters
- ACPR compliant
- Low output noise power
- Power down capability
- 70 mA average supply current (CDG suburban user model)
- JEDEC standard 5x5 mm TQFP-32 surface mount package

Applications

- CDMA1900/AMPS handsets

Pin Configuration

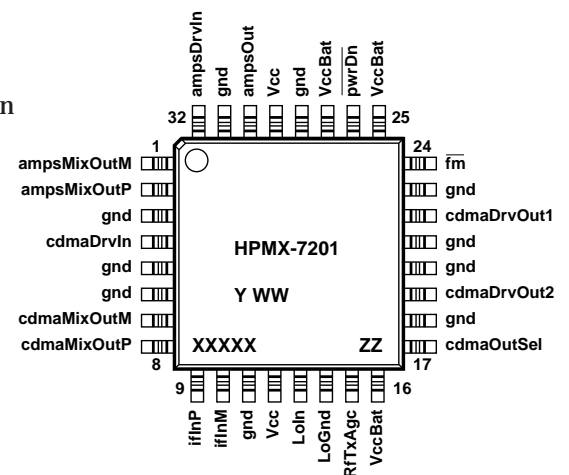

Agilent Technologies

Innovating the HP Way

HPMX-7201 Absolute Maximum Ratings^[1]

Parameter	Min.	Max.	Units
Supply Voltage		4.5	V
Battery Supply Voltage		4.5	V
Junction Temperature		150	°C
Case Temperature		125	°C
Storage Temperature	-55	125	°C
Input Power at iFln		15	dBm
Input Power at cdmaDrvIn		15	dBm
Input Power at ampsDrvIn		15	dBm
Input Power at LoIn		15	dBm

Thermal Resistance:^[2]

$$\theta_{jc} = 80^{\circ}\text{C/W}$$

Notes:

1. Operation of this device in excess of any of these parameters may cause permanent damage.
2. $T_{\text{JUNCTION}} = 150^{\circ}\text{C}$
3. This product is ESD sensitive. Handle with care to avoid static discharge.

HPMX-7201 Recommended Operating Conditions

$V_{cc} = 2.7$ to 3.6V , $V_{ccBat} = 2.7$ to 4.2V .

$T_{\text{ambient}} = -40^{\circ}\text{C}$ to 85°C .

IF Frequency (both bands): 130 MHz typically.

Typical cdmaMixOut Frequency: 1850 to 1910 MHz.

PCS Local Oscillator Frequency: 1720 to 1780 MHz for low side LO, which is often used to allow a single LO for transmit and receive operation, but is not required by the HPMX-7201.

Cellular Band RF Output Frequency: 824 to 849 MHz.

Cellular Band Local Oscillator Frequency: 954 to 979 MHz.*

* *High side* LO is required as the Cellular band upconverter features image rejection.

HPMX-7201 Standard Test Conditions

Unless otherwise noted, all test data was taken on packaged parts under the following conditions. The test circuit is shown in Figure 31 (demo schematic) and in Figure 32 (IF balun).

RF powers are into 50Ω unless specified otherwise.

$V_{cc} = 3.0\text{V}$, $V_{ccBat} = 3.6\text{V}$, $T_{\text{ambient}} = 25^{\circ}\text{C}$.

IF input frequency at iFlnP and iFlnM: 130 MHz. IF differential input voltage 480 mVp-p across a matched 360Ω differential impedance (240 mVp-p at iFlnP and iFlnM, with a single ended impedance of 180Ω). This input level is calculated from a 50Ω power source delivering -11 dBm to a lossy 7.2:1 impedance transforming network. The test circuit for this input is shown in Figure 32.

PCS CDMA LO input at LoIn: 1750 MHz at -11dBm single ended.

PCS CDMA RF frequency at cdmaMixOut, cdmaDrvIn, cdmaDrvOut1, and cdmaDrvOut2: 1880 MHz, matched to 50Ω .

Cellular AMPS LO input at LoIn: 965 MHz, -11 dBm.

Cellular RF frequency at ampsMixOut, ampsDrvIn, ampsDrvOut: 835 MHz, matched to 50Ω .

Functional Block Diagram

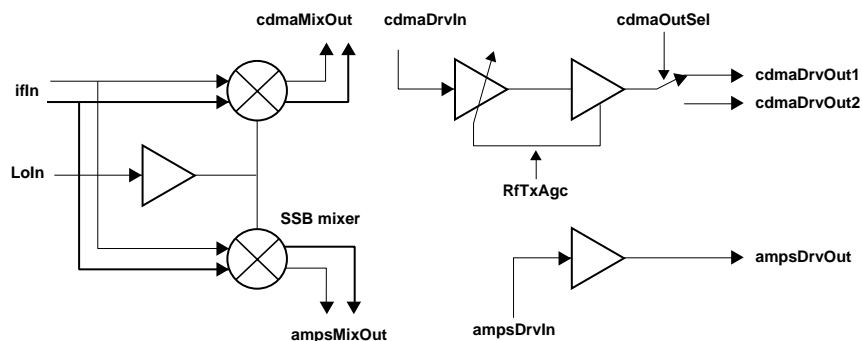

HPMX-7201 DC Specifications

Symbol	Parameters and Test Conditions	Min.	Typ.	Max.	Units
V_{IL_MAX}	V_{IL} Input Logic Low Voltage			0.5	V
V_{IH_MIN}	V_{IH} Input Logic High Voltage	2.5			V
	Power Down Supply current from Vcc $\overline{pwrDn} = V_{IL_MAX}, \overline{fm} = V_{IH_MIN}$		1	10	μA
	Power Down Supply current from VccBat $\overline{pwrDn} = V_{IL_MAX}, \overline{fm} = V_{IH_MIN}$		1	10	μA

PCS CDMA Upconverter

Symbol	Parameters and Test Conditions	Min.	Typ.	Max.	Units
Icc	Current Consumption		29	32	mA
Pout	Output Power ($V_{ifIn} = 480 \text{ mVp-p}^{[1]}$)	-9	-7		dBm
ACPR	Adjacent Channel Power Ratio at cdmaMixOut = -9 dBm		-60	-58	dBc/30 kHz
Cg	Conversion Power Gain ^[1]		4		dB
P1dB	1 dB compression point		0		dBm
OIP3	Output 3rd Order Intercept Point		10		dBm
Rx Noise	1930 to 1990 MHz Noise Floor		-155		dBm/Hz
Z_{IF}	Differential Impedance of IF port		360		Ω
	LO port to RF port leakage		-30		dBm
	IF signal present at LO port (IF to LO leakage)		-88		dBm
	RF signal present at LO port (RF to LO leakage)		-41		dBm
	2x LO out of RF port		-20		dBm
	3x LO out of RF port		-30		dBm
	Other Spurious emissions at RF port: (LO ± 3 IF)		-60		dBm

Note:

1. This input level is calculated from the input power delivered to a test circuit with measured loss as specified in the *Standard Test Conditions*. If an additional resistance is added across the IFInP and IFInM pins (to set the IF filter terminating impedance) the input voltage for a fixed input power will be reduced. To maintain this input voltage in this case, the input power to the IF port must be increased, resulting in an apparent decrease in power gain.

PCS CDMA Variable Gain Amplifier

Symbol	Parameters and Test Conditions	Min.	Typ.	Max.	Units
IccBat	Battery Current Consumption ^[2]	RFTxAgc = 0.3 V	28	35	mA
		RFTxAgc = 2.7 V	100	110	mA
Gain	Gain ^[2]	RFTxAgc = 0.3 V	-10	-5	dB
		RFTxAgc = 2.7 V	21	23	dB
ACPR	Adjacent Channel Power Ratio	Pout = +11 dBm	-59	-52	dBc/30 kHz
P1dB	1dB compression point	RFTxAgc = 2.7V	17		dBm
	Isolation between cdmaDrvOut1 and cdmaDrvOut2 with cdmaOut1 selected		20		dB
Rx Noise	1930 to 1990 MHz Noise Floor	RFTxAgc = 2.7V	-142		dBm/Hz

Note:

2. The PCS CDMA VGA features adaptive biasing such that the supply current (from VccBat) will vary with RFTxAgc voltage. Please see the *Typical Performance Graphs* for more information on the VGA operation.

Cellular AMPS Upconverter

Symbol	Parameters and Test Conditions	Min.	Typ.	Max.	Units
Icc	Current Consumption		23	26	mA
P _{ampsMixOut}	Output Power at Vin = 480mVp-p ^[3]		-7		dBm
Z _{IF}	Differential Impedance of IF port		360		Ω
FMnoise	Rx band Noise		-145		dBm/Hz
	F _{ampsMixOut} = 835 MHz, F _{noise-test} = 880 MHz				
	LO port to RF port leakage		-30		dBm
	IF to LO Leakage		-89		dBm
	RF to LO Leakage		-65		dBm
IR	Image Rejection		dBc		30
	F _{image} = F _{IF} + F _{LO} = 130 MHz + 965 MHz = 1095 MHz				

Note:

3. This input level is calculated from the input power delivered to a test circuit with measured loss as specified in the *Standard Test Conditions*. If an additional resistance is added across the IFInP and IFInM pins (to set the IF filter terminating impedance) the input voltage for a fixed input power will be reduced. To maintain this input voltage in this case, the input power to the IF port must be increased, resulting in an apparent decrease in power gain.

Cellular AMPS Driver

Symbol	Parameters and Test Conditions	Min.	Typ.	Max.	Units
Icc-bat	Battery Current consumption		30	34	mA
SSGain	Small Signal Gain, P _{ampsDrvIn} = -25 dBm	20	22		dB
Psatout	Output Power at P _{ampsDrvIn} = P _{ampsMixOut}	10	11		dBm
P1dB	1dB Compression Point		8		dBm
Noise	Rx band Noise, P _{ampsDrvOut} = +11 dBm		-134		dBm/Hz
	F _{ampsDrvOut} = 835 MHz, F _{noise-test} = 880 MHz				

HPMX-7201 Pin Description

No.	Name	Description	Functionality
1	ampsMixOutM	AMPS mixer output	Open collector output of AMPS upconverter, connection to Vcc is required. If a single ended output is required from ampsMixOutM, then ampsMixOutP needs to be biased to Vcc and RF terminated.
2	ampsMixOutP	AMPS mixer output	Open collector output of AMPS upconverter, connection to Vcc is required. If a single ended output is required from ampsMixOutP, then ampsMixOutM needs to be biased to Vcc and RF terminated.
3	Gnd	Ground	
4	cdmaDrvIn	CDMA Amplifier input	RF input, for CDMA driver. A DC bias is present on this pin so a DC blocking capacitor is required.
5	Gnd	Ground	
6	Gnd	Ground	
7	cdmaMixOutM	CDMA mixer output	Open collector output of CDMA upconverter, connection to Vcc is required. If single ended output is required from cdmaMixOutM, cdmaMixOutP needs to be biased to Vcc and RF terminated.
8	cdmaMixOutP	CDMA mixer output	Open collector output of CDMA upconverter, connection to Vcc is required. If single ended output is required from cdmaMixOutP, cdmaMixOutM needs to be biased to Vcc and RF terminated.
9	iFInP	IF differential input	IF differential input with nominal input impedance of 360Ω differential. If a single ended 50 Ω source is used on the IF port, Figure 32 illustrates an example circuit for testing.
10	iFInM	IF differential input	IF differential input. See iFInP (Pin 9).
11	gnd	Ground	
12	Vcc	Regulated DC Voltage connection	Regulated Vcc connection to IC mixer circuits, separated from amplifier supply voltage to avoid non-linear mixer effects due to supply coupling.
13	LoInP	LO input Positive side	Differential LO input with high input impedance. This pin requires external AC coupling. If a single ended 50Ω source is used, a 56Ω resistor should be connected directly between LoInP and LoInM, and LoInM RF bypassed to ground. The LO signal should be AC coupled into LoInP.
14	LoInM	LO input Negative side	Differential LO input, see LoInP (pin 13).
15	RfTxAgc	PCS Tx VGA gain control voltage	DC input, controls CDMA amplifier gain and bias current see Typical Performance graphs for more information. This pin appears as a 100kΩ resistance to ground. If this pin is connected to a Pulse Density Modulated signal (PDM) an external discrete filter is needed to generate the gain control voltage input.
16	VccBat	Battery connection	Amplifier DC supply voltage pin. This supply can be connected directly to the unregulated battery voltage. External decoupling capacitors are typically required.
17	cdmaOutSel	PCS band select	DC input, toggles CDMA amplifier output between cdmaOut1 (pin 22) and cdmaDrvOut2 (pin 19). A logic 1 selects cdmaDrvOut1, and a logic 0 selects cdmaDrvOut2. At a logic high, this pin draws less than 3μA. At a logic low level this pin sources 1μA.
18	Gnd	Ground	
19	cdmaDrvOut2	CDMA Amplifier output #2	CDMA RF output from amplifier stage. An external connection to VccBat is required. CdmaOutSel is used to enable either this pin or the cdmaDrvOut1.
20	Gnd	Ground	VGA ground
21	Gnd	Ground	VGA ground
22	cdmaDrvOut1	CDMA Amplifier output #1	CDMA RF output from amplifier stage. An external connection to VccBat is required. CdmaOutSel is used to enable either this pin or the cdmaDrvOut2.
23	Gnd	Ground	

HPMX-7201 Pin Description, continued

No.	Name	Description	Functionality
24	$\overline{\text{fm}}$	Mode select	DC input, Selects between AMPS and CDMA modes. A logic 0 selects AMPS mode, while a logic 1 selects PCS CDMA mode. See Table 1 in the <i>Theory of Operation</i> section for more information. At a logic high, this pin draws less than 3 μA . At a logic low level this pin sources 1 μA .
25	VccBat	Battery connection	Amplifier DC supply voltage pin. This supply can be connected directly to the unregulated battery voltage. External decoupling capacitors are typically required.
26	$\overline{\text{pwrDn}}$	Power down	DC input, a logic low will power down the HPMX-7201, a logic high turns the IC on. This input controls the bias cell of the HPMX-7201, allowing it to shutdown all sections of the chip regardless of which Vcc supply (Vcc or VccBat) the section uses. At a logic high, this pin draws less than 30 μA . At a logic low level this pin sources less than 1 μA typically.
27	VccBat	Battery connection	Amplifier DC supply voltage pin. This supply can be connected directly to the unregulated battery voltage. External decoupling capacitors are typically required.
28	Gnd	Ground	
29	Vcc	Regulated DC	Regulated Vcc connection to IC mixer circuits, separated from Voltage connection amplifier supply voltage to avoid non-linear mixer effects due to supply coupling.
30	ampsDrvOut	AMPS amplifier output	AMPS RF output from amplifier, an external connection to Vcc is required.
31	Gnd	Ground	
32	ampsDrvIn	AMPS amplifier input	Input to AMPS amplifier. Internally AC coupled. A matching circuit is required for operation from a 50 Ω source impedance.

HPMX-7201 Typical Performance

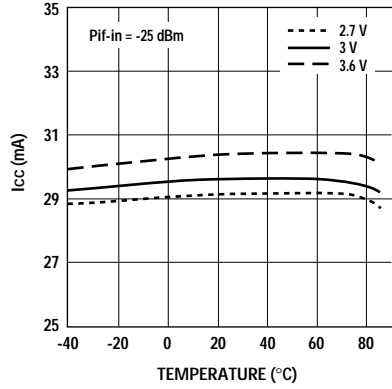

Figure 1. CDMA Upconverter Icc vs. Vcc and Temperature.

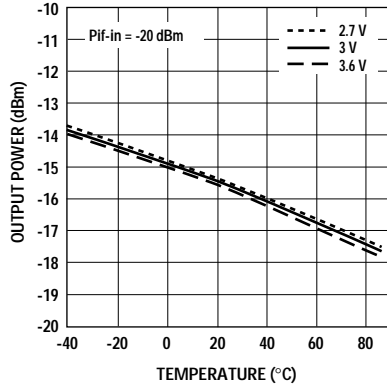

Figure 2. CDMA Upconverter Output Power vs. Temperature and Vcc.

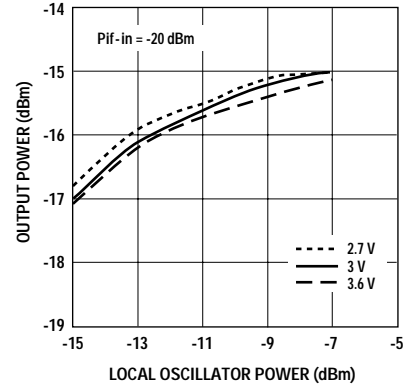

Figure 3. CDMA Upconverter Output Power vs. LO Power and Vcc.

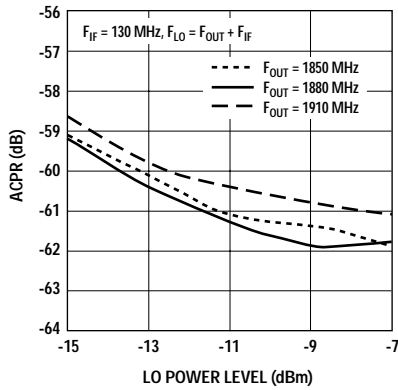

Figure 4. CDMA Upconverter ACPR vs. LO Power and Frequency.

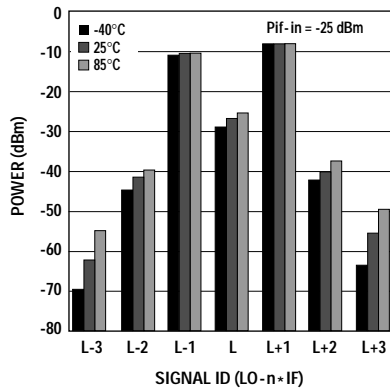

Figure 5. CDMA Upconverter Output Spectrum vs. Temperature.

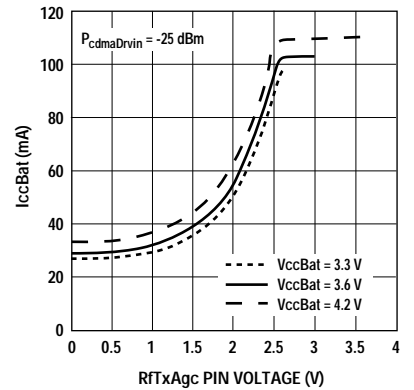

Figure 6. CDMA Driver IccBat vs. V(RfTxAgc) and VccBat.

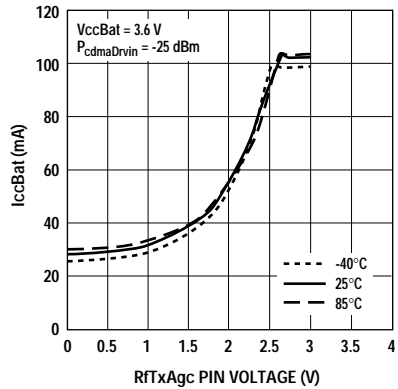

Figure 7. CDMA Driver IccBat vs. V(RfTxAgc) and Temperature.

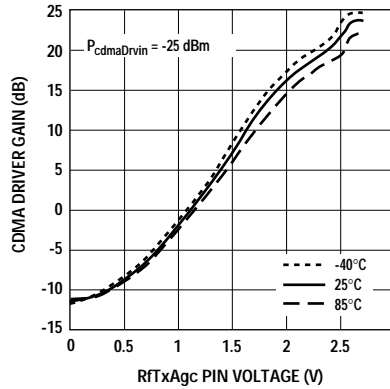

Figure 8. CDMA Driver Gain vs. V(RfTxAgc) and Temperature.

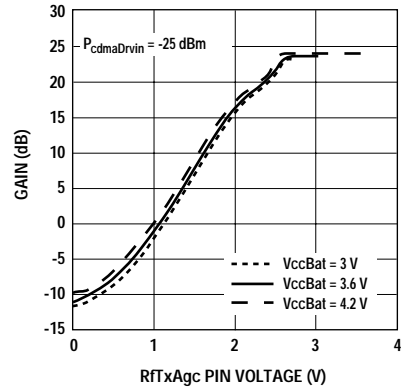

Figure 9. CDMA Driver Gain vs. V(RfTxAgc) and VccBat.

HPMX-7201 Typical Performance , continued

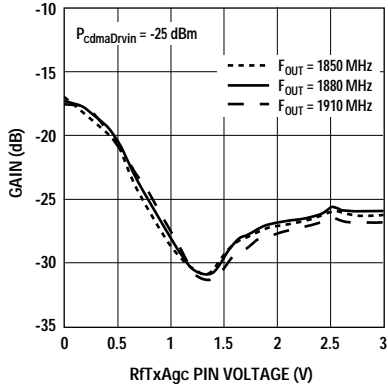

Figure 10. CDMA Driver Isolation (Output 2 to Output 1) vs. V(RfTxAgc) and Frequency.

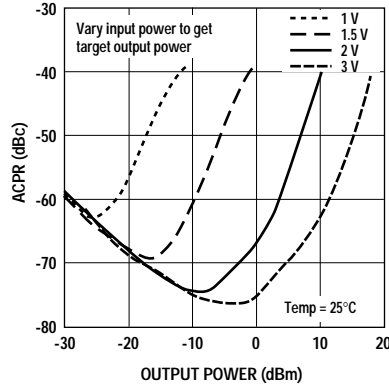

Figure 11. CDMA Driver ACPR vs. Output Power and V(RfTxAgc).

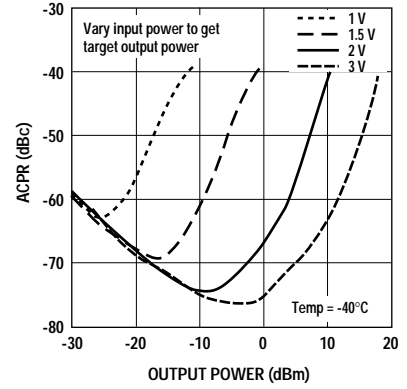

Figure 12. CDMA Driver ACPR vs. Output Power and V(RfTxAgc).

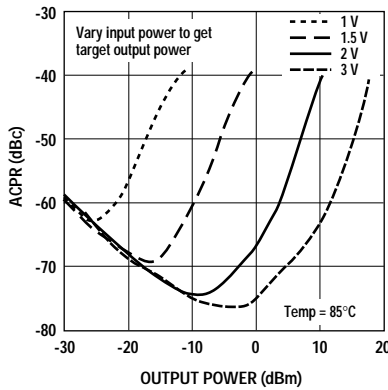

Figure 13. CDMA Driver ACPR vs. Output Power and V(RfTxAgc).

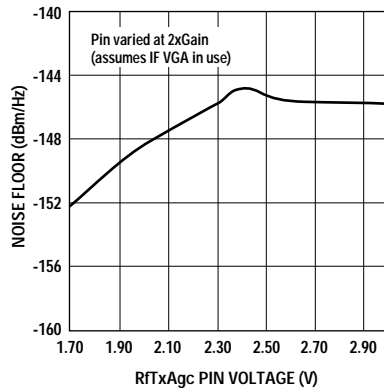

Figure 14. CDMA Driver RX Band Noise Floor vs. V(RfTxAgc).

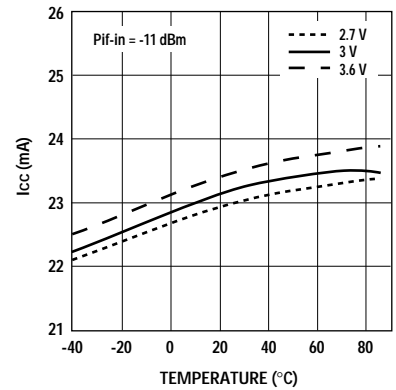

Figure 15. AMPS Upconverter Icc vs. Temperature and Vcc.

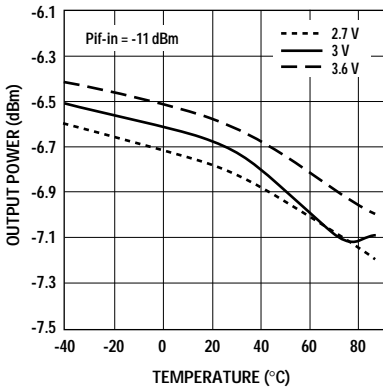

Figure 16. AMPS Upconverter Output Power vs. Temperature and Vcc.

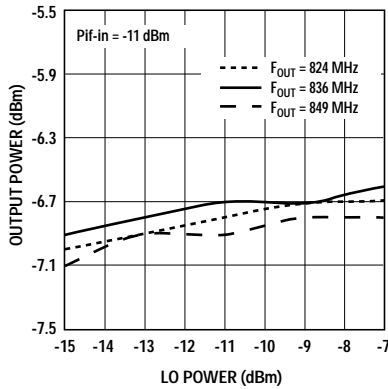

Figure 17. AMPS Upconverter Output Power vs. LO Power and Frequency.

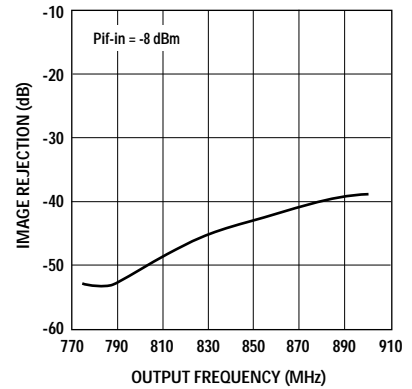

Figure 18. AMPS Upconverter Image Rejection vs. Output Frequency.

HPMX-7201 Typical Performance , continued

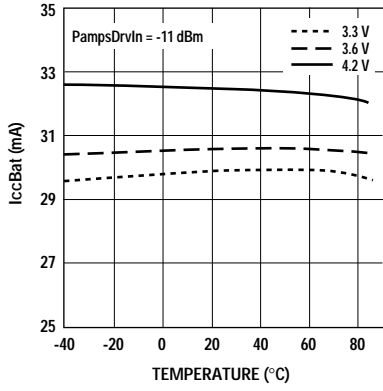

Figure 19. AMPS Driver IccBat vs. Temperature and VccBat.

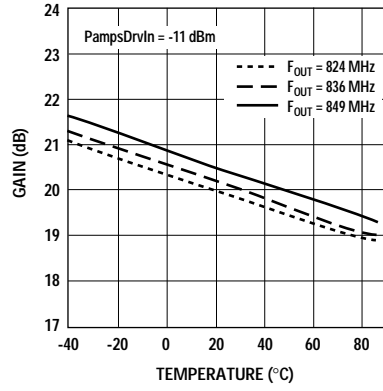

Figure 20. AMPS Driver Gain vs. Temperature and Frequency.

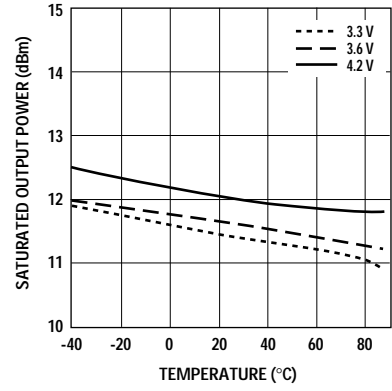

Figure 21. AMPS Driver Output 3 dB Compression Power vs. Temperature and VccBat.

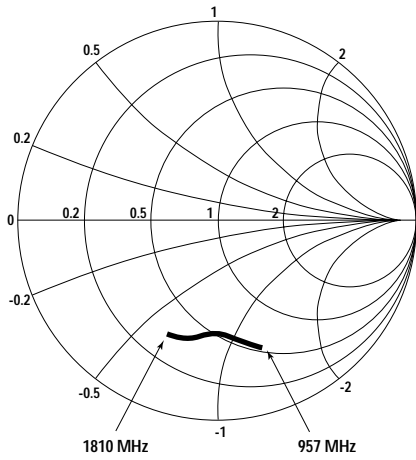

Figure 22. LO Port Input Impedance vs. Frequency.

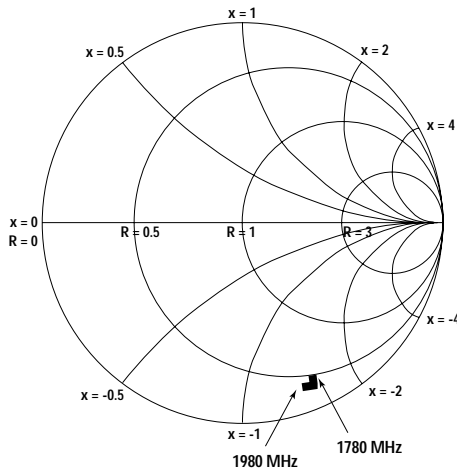

Figure 23. cdmaMixOut Output Impedance vs. Frequency.

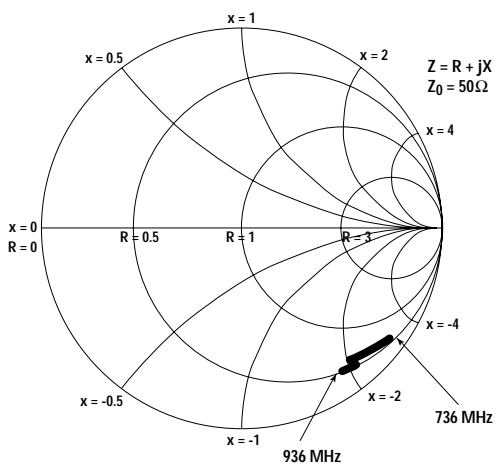

Figure 24. ampsMixOut Output Impedance vs. Frequency.

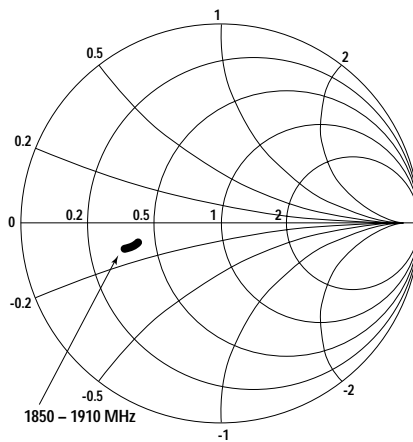

Figure 25. cdmaDrvIn Input Impedance vs. Frequency.

HPMX-7201 Typical Performance , continued

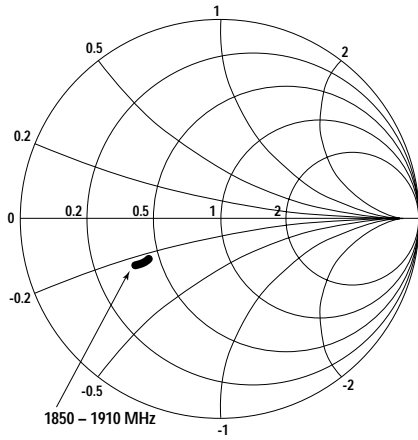

Figure 26. cdmaDrvOut Output Impedance vs. Frequency.

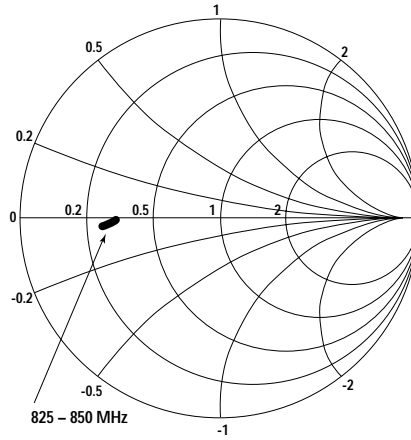

Figure 27. ampsDrvIn Input Impedance vs. Frequency.

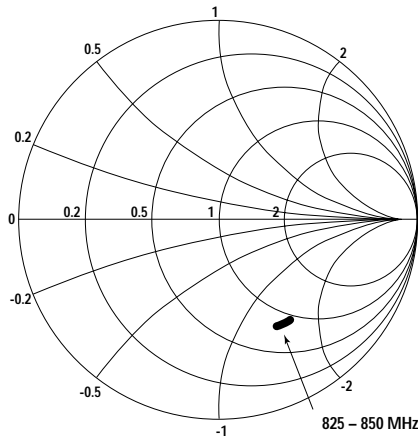

Figure 28. ampsDrvOut Output Impedance vs. Frequency.

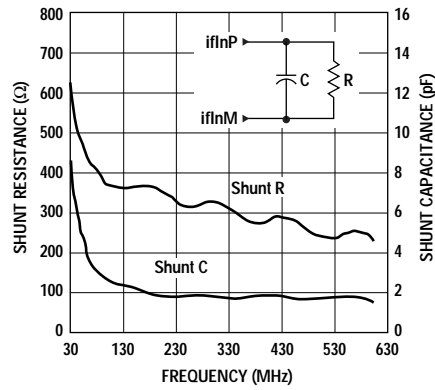

Figure 29. IF Input Port Equivalent Circuit (CDMA Mode) vs. Frequency.

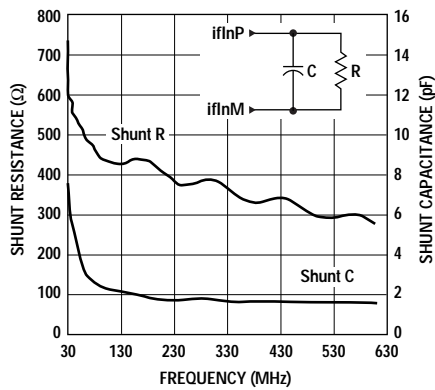

Figure 30. IF Input Port Equivalent Circuit (AMPS Mode) vs. Frequency.

Theory of Operation

The HPMX-7201 is designed for operation in Dual Band/Dual mode PCS/AMPS handsets. The device has four modes of operation set by the pins $\overline{\text{pwrDn}}$, $\overline{\text{fm}}$, and cdmaOutSel as represented in Table 1. Additionally the gain in PCS CDMA mode is adjustable by controlling the RfTxAgc pin. Refer to Figure 31 for reference on circuit descriptions.

PCS CDMA Mode

The PCS CDMA chain consists of a double balanced active mixer, a variable gain amplifier (VGA) and an output switch. The output switch connects the VGA to one of two output pins according to the logic level present at the cdmaOutSel pin (pin 17). The same VGA is used for both outputs, so the switch is typically used only when split band filters are present at the output of the HPMX-7201.

The differential IF input to the balanced mixer ifInP and ifInM (pins 9 and 10) have a nominal differential impedance of 360Ω . If a single ended 50Ω source is used to drive these inputs, see Figure 32 for an example test circuit.

The IF and LO inputs are common to both PCS and AMPS. The output of the CDMA mixer is a differential signal across cdmaMixOutP and cdmaMixOutM (pins 8 and 7). Both pins are open collector and need external connections to V_{cc} . See Interface Circuits section for more information. If single ended operation is required the output can be taken from cdmaMixOutP or cdmaMixOutM with the other output being bypassed. A resistor can be placed across the two pins to set the output impedance.

The HPMX-7201 PCS CDMA upconverter mixer includes an LO buffer which allows operation at low LO input power and low supply levels. With a LO input of -11 dBm and an IF input differential signal of 480 mVp-p , the upconverter typically delivers -7 dBm when matched to a 50Ω load at 1880 MHz . The mixer ACPR performance is $-60\text{ dBc}/30\text{ kHz}$ (at 1.25 MHz offset frequency) with an output noise power of -155 dBm/Hz at $+80\text{ MHz}$ offset.

The mixer output is typically connected through an off-chip filter and then connected to the VGA. The input to the VGA is

single ended (cdmaDrvIn , pin 4) and is easily matched to 50 ohms . The VGA gain ranges from -10 to $+23\text{ dB}$ and is controlled via the RfTxAgc pin (pin 15). If connection to a Pulse Density Modulation signal is used, an external filter is required to generate the control voltage for this input.

The VGA is implemented in a 2 stage common-emitter configuration which offers 33 dB (typ.) gain control range (-10 dB to 23 dB gain) with a linear gain (in dB) vs. voltage transfer characteristic. See the *Typical Performance Graphs* for more information.

The HPMX-7201 VGA features adaptive biasing, which decreases the bias current to the VGA at lower gain levels, thus decreasing the power consumption of the VGA, see the typical performance graphs for more information. The ACPR performance is also a function of the bias current and the linearity increases at higher RfTxAgc voltages. When used in association with an IF AGC amplifier this feature allows the required ACPR to be achieved at the minimum possible supply current for each targeted output power. See the Applications Notes section for more detail on adaptive biasing and optimizing the supply current drawn by the HPMX-7201 in a handset.

The output of the VGA is routed through a band switch controlled by the cdmaOutSel pin (pin 17), Table 2 represents the functionality of this switch. This feature can be used to drive a split band PCS Tx filter. Split band filters are often needed to minimize receive band noise injected by the transmit chain into the LNA through the duplexer. This technique is frequently necessary to meet receiver sensitivity requirements due to the closely spaced Rx and Tx frequency allocations used for PCS systems.

Table 1: Modes of Operation

$\overline{\text{pwrDn}}$	$\overline{\text{fm}}$	cdmaOutSel	Mode
0	X	X	Power down
1	0	X	AMPS mode
1	1	0	PCS CDMA Output 2
1	1	1	PCS CDMA Output 1

X indicates a don't care state

Table 2: PCS Output Switch Operation

cdmaOutSel	Active Output
Logic 1 (>2.5V)	cdmaDrvOut1 (pin 22)
Logic 0 (<0.5V)	cdmaDrvOut2 (pin 19)

AMPS Mode

The AMPS chain consists of an image reject mixer and a driver amplifier. The image reject mixer eliminates the requirement for an image reject filter between the upconverter and the amplifier, however the output of the mixer and the input to the amplifier are routed externally to provide the option of using a filter.

The AMPS upconverter consists of two double balanced active mixers driven by quadrature-phased LO and IF signals. The LO and IF phase shifters are implemented on-chip.

The differential IF input to the mixer is shared with the PCS band, and is explained in the PCS CDMA mode description. The output of the double balanced mixer is also differential and appears across ampsMixOutM (pin 1) and ampsMixOutP (pin 2). As the mixer output is open collector, these pins need an external connection to Vcc. If single ended operation is required, the output can be taken from ampsMixOutM with ampsMixOutP being biased to Vcc and RF terminated. A resistor can be placed across the two pins to set the impedance of this port to a suitable level.

With a LO power of -11 dBm and an IF input voltage of 480 mVp-p differential, the upconverter delivers -7 dBm into a 50Ω load with a typical image rejection of 30 dBc. At an output power of -7 dBm, the mixer exhibits a noise power of -145 dBm/Hz at 45 MHz carrier offset.

The AMPS driver amplifier input is internally AC coupled with an on chip capacitor. An external matching circuit is required to transform the impedance of the input to the required external filter impedance, which is nominally 50Ω. The output of the AMPS amplifier needs to be connected to Vcc via an external inductor. In most applications a simple 2 element matching network can provide an acceptable match to 50Ω. At 835 MHz the driver produces 22 dB of gain and an output P1dB of 8 dBm. At 11 dBm output power into a 50Ω load, the receive band noise is typically -134 dBm/Hz.

Example Circuits

This section illustrates several example circuits for the HPMX-7201. The Figure 31 circuit is based on the HPMX-7201 demo board and can be used as a starting point for designing with the HPMX-7201. Note that the ground pins on the part are not shown. Proper decoupling of Vcc and VccBat is also required. Additional decoupling may be required on the control lines. In some applications RfTxAgc is driven with a Pulse Density Modulated (PDM) signal, in this case, a filter (typically R-C) is needed. See the following section on supply voltage partitioning for more information.

The circuit shown in Figure 32 is an example of how to interface the HPMX-7201 to a 50Ω IF source for testing purposes. In most applications, the IF port impedance is set by an IF filter with an impedance higher than 50Ω. This is the circuit used for testing the HPMX-7201, and is also present on the HPMX-7201 demo board.

PCB Layout and Supply Decoupling

The HPMX-7201 can optionally operate from separate regulated and unregulated voltage supplies to save regulator current.

To insure optimum isolation between the separate sections of the HPMX-7201, it is recommended that decoupling capacitors be used, as well as good RF PCB layout techniques. A star topology with each Vcc (or VccBat) pin on the device having a high frequency decoupling capacitor located close by followed by an individual trace to a central Vcc node with good low frequency decoupling can be used to minimize supply coupling. To further reduce coupling use a separate vias to the ground plane for each decoupling capacitor and ground pin, as this minimizes common ground inductance.

System Level Diagram

In a typical application and with a maximum input signal at the IF input port Figure 33 shows the expected power levels and voltages at different points of the HPMX-7201. These measurements are made using a high impedance probe to ensure minimal loading of the circuit with the probe. Figure 33 is also included to show how the HPMX-7201 interfaces with other components to form a dual-band, dual-mode handset.

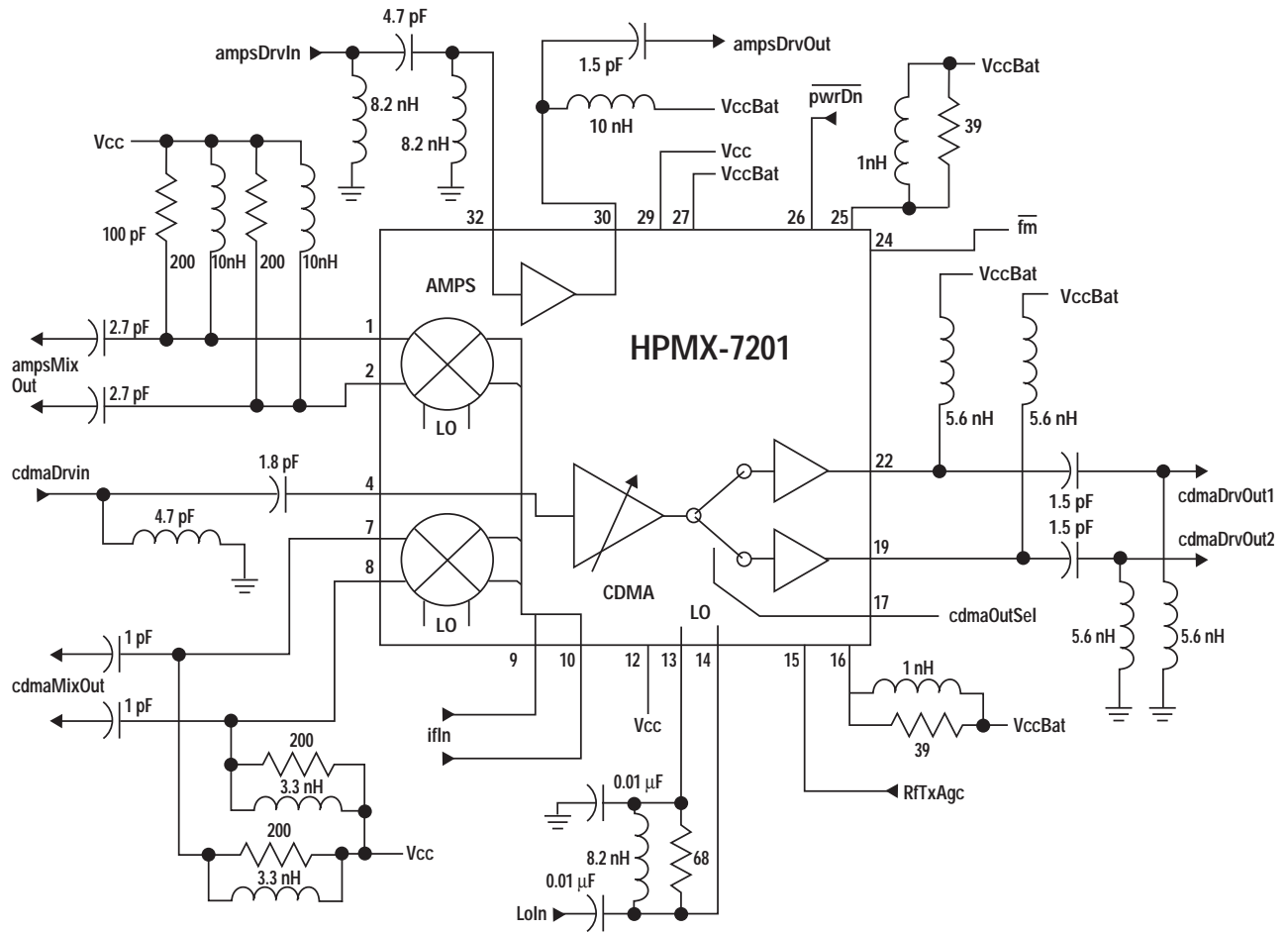

Figure 31. Example Reference Circuit for the HPMX-7201.

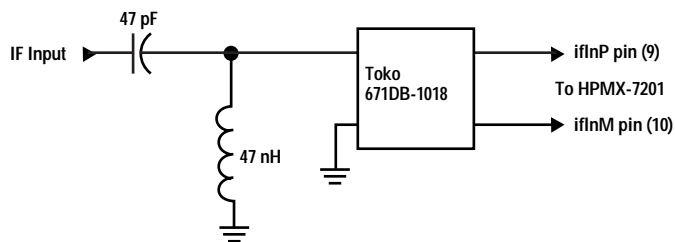

Figure 32. Test Circuit for Single-ended 50Ω IF Operation.

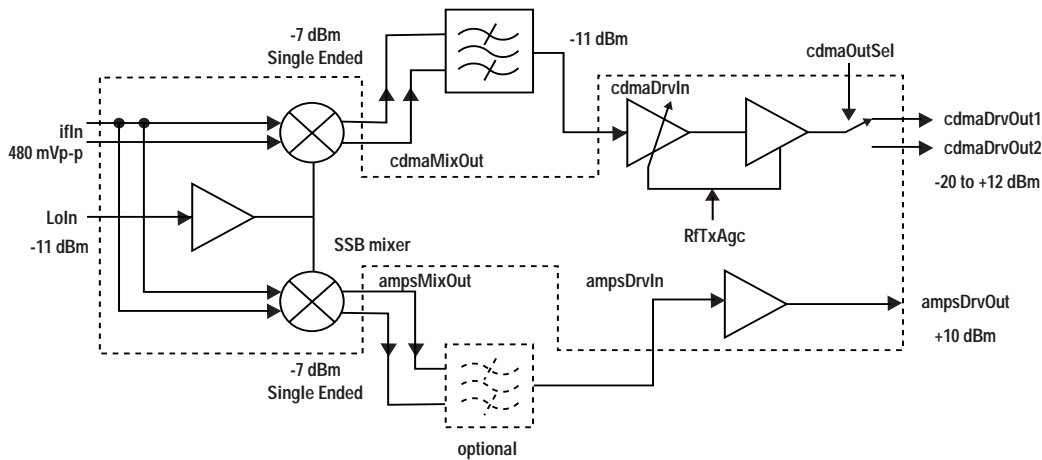

Figure 33. Expected Power and Voltage Levels.

Applications Notes

This chip is part of Agilent's CDMA Chipset solution. CDMA, or Code Division Multiple Access, uses correlative codes to distinguish one user from another. Frequency divisions are also used, but in a much larger bandwidth (1.25 MHz) than in AMPS (Advanced Mobile Phone System) applications. In CDMA, a single user's channel consists of a specific frequency combined with a unique code. Channels with other codes appear to a receiver as uncorrelated interference. CDMA also uses sectored cells to increase capacity. One of the major differences in CDMA is its ability to use the same frequency in all sectors of all cells.

Capacity in a CDMA system can be increased by minimizing the interference caused by other users (each with their own code) on the CDMA channel. Since each users transmitted signal appears as interference to all other users, having the mobile-stations transmit at the lowest possible power is especially important for CDMA systems, although it is important for all multiple access systems to reduce interference.

To accomplish this, the CDMA base-station establishes a very tight closed-loop control of the output power of each mobile, commanding it to adjust its power up or down by 1 dB every 1.25 ms, with the goal of setting the power received at the base-station antenna to the minimum required. As a mobile station traverses a cell, its output power will be decreased when it approaches the base-station, and it will be increased as it gets farther away from the center of the cell.

The main objective, as explained above, for continuously adjusting the output power of a mobile in a CDMA system is to optimize capacity. Using adaptive-bias techniques in the RF section of CDMA mobile phones, the closed-loop requirements can be capitalized on to provide enhanced standby and talk-time performance, while at the same time delivering superior linearity at high output powers.

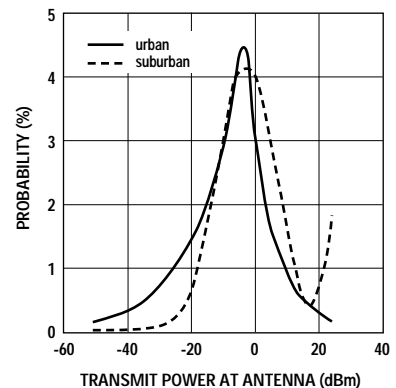

Figure 34. Probability Distribution of Mobile Transmit Power.

The TIA/EIA-98-C CDMA standard requires the output power of the mobile-station to vary from -50 to $+23$ dBm (TIA/EIA-98-C, *Recommended minimum performance standards for dual-mode spread spectrum mobile-stations*). The CDMA Development Group (CDG) has published statistical profiles for the mobile-station transmit power, that were generated from actual field test data from deployed CDMA units. Figure 34 shows the probability distributions for urban and suburban topographies. It is rather clear from inspecting the curves in Figure 34, that the average

transmit power in the mobile (10.6 dBm – suburban, 5.4 dBm – urban) is significantly lower than the maximum. (Note: the average transmit power is not at the peak of the distribution functions shown in Figure 34 because of the logarithmic scale on the x-axis).

Current consumption in the transmit chain at maximum output is many times considered the *only* critical figure of merit for selecting the RF components to be used in a handset design. Current consumption at maximum output power is of course still important, for both RF and thermal design reasons. For example, an additional incentive for keeping the current consumption maximum output power as low as possible, is that the statistical profiles will vary from user to user depending on usage patterns and conditions. In other words, although the statistical profiles published by the CDG obey the laws of large numbers, the statistical profile for an individual user may differ significantly.

Having said that, the real figure of merit for CDMA mobile phone should be the *statistical-average current consumption*, $I_{cc-\mu}$ which is the current consumption integrated over the user's statistical profile. In fact, the CDG's talk-time method of measurement consists of continuously sweeping the output power of the mobile from -50 to +23 dBm according to the statistical profiles shown in Figure 34, to arrive at an industry-standard definition of talk-time (CDG Stage 4 system performance tests).

If the RF components have a fixed bias, then the current consumption at maximum output power is the same as the statistical-average current consumption. This is often the case with the baseband and first IF stages of many radio designs, but in the higher power stages, particularly the PA driver and the PA itself the supply current is a strong function of output power. However, if the RF components use adaptive-bias techniques such that the current consumption decreases with the output power, then the maximum and statistical-average current consumption can be set independently, optimizing each one as needed. The current consumption at maximum output power is designed to deliver the required linearity, while the statistical-average current consumption is designed to maximize talk-time. Figure 34 illustrates the fact that the mobile spends – statistically – little time at the maximum output power, and therefore the current consumption at that point has only a minor influence on the statistical-average current and, by extension, on talk-time.

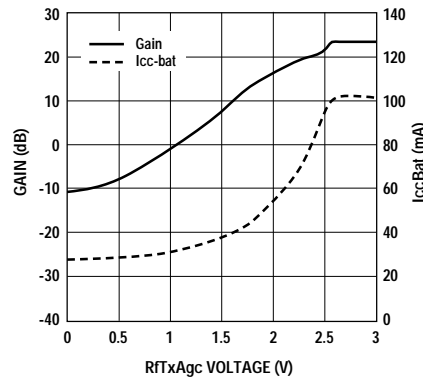

Figure 35. HPMX-7201 RF VGA Gain and Supply Current Consumption vs. RfTxAgc Voltage.

Figure 35 illustrates the effect of using adaptive bias techniques in the RF VGA of the HPMX-7201. The plot shows the measured gain and current consumption vs. the gain control voltage, RfTxAgc, for one of the CDMA outputs. As the gain is reduced, and hence the output power, the current consumption decreases while still maintaining an adequate ACPR. Note that the current plotted is only the VGA current, the mixer current is not included.

Figure 36 shows the *total* current consumption for the HPMX-7201 versus output power *for a constant ACPR of -55 dBc/30 KHz* (this ACPR was selected arbitrarily; similar plots can be produced for other values). The plot was generated by adjusting the input power and the gain control voltage to achieve the ACPR= -55 dBc at the lowest possible current consumption, for each output power. The HPMX-7201 can deliver up to +14 dBm of power. The lower trace on the plot show how the total current varies versus output power if the gain control voltage is adjusted continuously. The next (middle) trace illustrates the performance of the device if the gain control voltage adjustment is limited to 3 discrete states, rather than a continuum. This method simplifies the operation of the part, at the expense of a higher statistical-average current consumption. The upper trace illustrates the performance if the gain control voltage adjustment is further limited to only 2 discrete states.

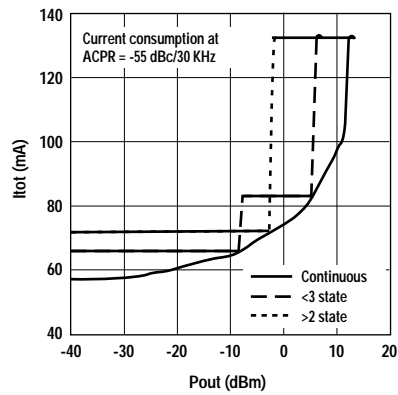

Figure 36. HPMX-7201 Total Current Consumption vs. Output Power and Control Method.

Figure 37 shows the statistical-average current consumption of the upconverter/driver RFICs versus the required maximum output power out of the device. The data is generated by integrating the curves in Figure 36 over the complete output power range of the mobile under the suburban user model. The suburban model gives a higher statistical-average current than the urban model due to the probability distribution tail at high powers. The choice of maximum output power is determined by the gain of the power amplifier, and the loss of the filters, duplexers etc. that follow the upconverter driver amplifier.

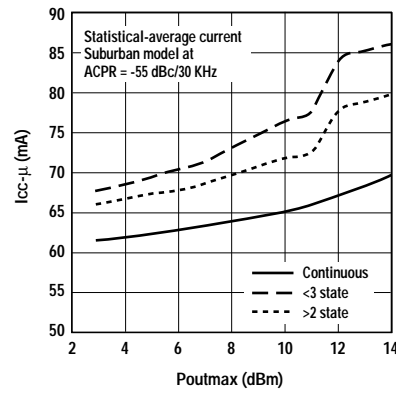

Figure 37. HPMX-7201 Statistical-Average Current Consumption vs. Desired Maximum Output Power.

Figure 36 and Figure 37 illustrate the significant advantage of using adaptive-bias techniques in CDMA mobile phones. The HPMX-7201 has a total current consumption (upconverter + driver) of 130 mA when delivering +14 dBm of output power with an ACPR = -55 dBc/30 KHz. However, as summarized in Table 3, the statistical-average current consumption can be as low as 70 mA, if the phone can perform a continuous control of the RF VGA. The statistical average current consumption is still a low 85 mA, even if an extremely simple 2-state gain control adjustment is used.

Even with a simple 2 state control algorithm, the average supply current is still significantly below the peak current of 130 mA at maximum power.

Table 3. Statistical Average Supply Current, Pout max = 14 dBm.

Control Method	Average Supply Current
Analog (N states)	70 mA
3 State	80 mA
2 State	87 mA

Clearly, relatively low statistical-average current consumption can be achieved in the transmit RF section of the mobile if adaptive-bias techniques are used. Use of adaptive bias techniques at lower output powers combined with the HPMX-7201's excellent linearity at high output powers provides manufacturing margin for linearity while also maintaining extended talk time.

Part Number Ordering Information

Part Number	No. of Devices	Container
HPMX-7201-BLK	10	Bulk
HPMX-7201-TR1	1000	Tape and Reel

Package Dimensions JEDEC Standard TQFP-32 Package

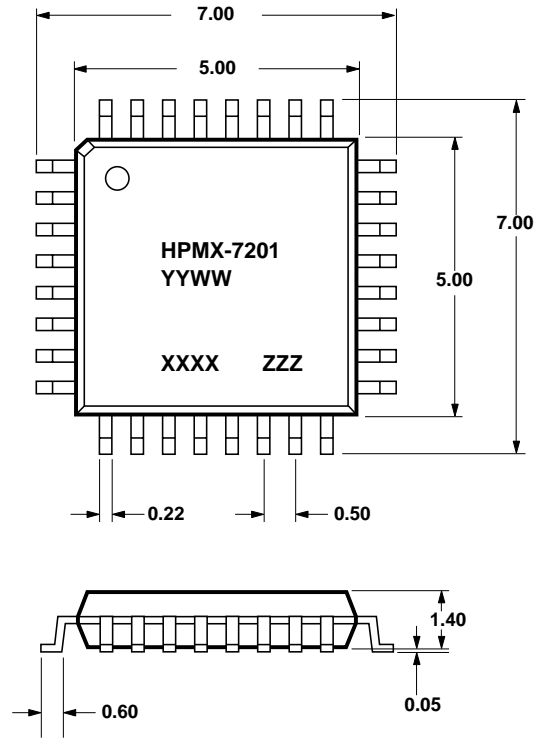

ALL DIMENSIONS SHOWN IN mm

Tape Dimensions and Product Orientation for Outline 5 mm x 5 mm TQFP-32

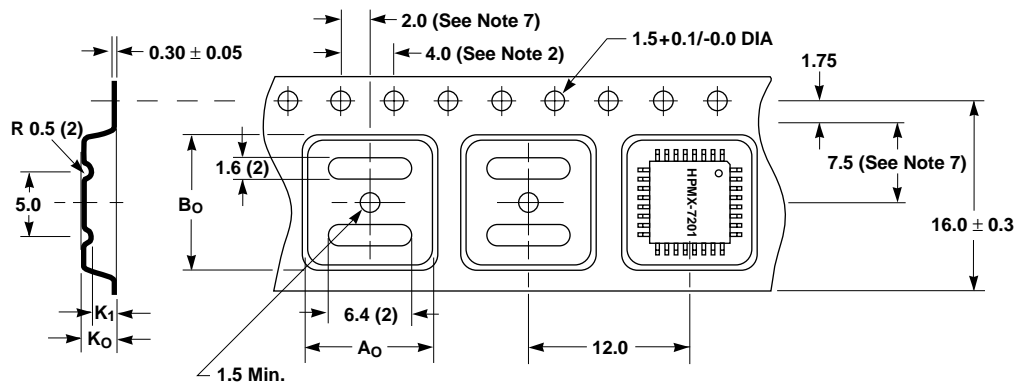
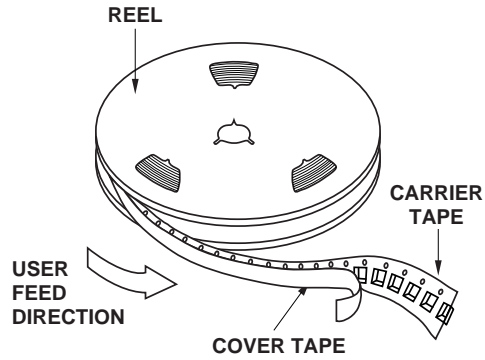

Cover tape width = $13.3 \pm 0.1\ mm$
 Cover tape thickness = $0.051\ mm$ (0.002 inch)

$A_0 = 9.3\ mm$
 $B_0 = 9.3\ mm$
 $K_0 = 2.2\ mm$
 $K_1 = 1.6\ mm$

NOTES:

1. Dimensions are in millimeters
2. 10 sprocket hole pitch cumulative tolerance ± 0.2
3. Chamber not to exceed 1 mm in 100 mm
4. Material: black conductive Advantek™ polystyrene
5. A_0 and B_0 measured on a plane 0.3 mm above the bottom of the pocket.
6. K_0 measured from a plane on the inside bottom of the pocket to the top surface of the carrier.
7. Pocket position relative to sprocket hole measured as true position of pocket, not pocket hole.

www.semiconductor.agilent.com

Data subject to change.

Copyright © 2000 Agilent Technologies, Inc.
5968-9131E (6/00)



Agilent Technologies

Innovating the HP Way