



CAT64LC10/20/40

1K/2K/4K-Bit SPI Serial EEPROM

FEATURES

- SPI bus compatible
- Low power CMOS technology
- 2.5V to 6.0V operation
- Self-timed write cycle with auto-clear
- Hardware reset pin
- Hardware and software write protection
- Commercial, industrial and automotive temperature ranges
- Power-up inadvertant write protection
- RDY/BSY pin for end-of-write indication
- 1,000,000 program/erase cycles
- 100 year data retention

DESCRIPTION

The CAT64LC10/20/40 is a 1K/2K/4K-bit Serial EEPROM which is configured as 64/128/256 registers by 16 bits. Each register can be written (or read) serially by using the DI (or DO) pin. The CAT64LC10/20/40 is manufactured using Catalyst's advanced CMOS

EEPROM floating gate technology. It is designed to endure 1,000,000 program/erase cycles and has a data retention of 100 years. The device is available in 8-pin DIP, SOIC and TSSOP packages.

PIN CONFIGURATION

DIP Package (P, L)

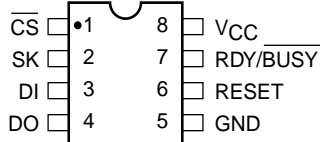

SOIC Package (J, W)

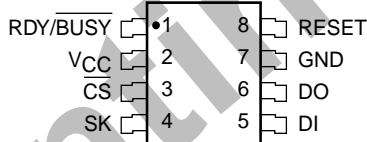

TSSOP Package (U, Y)

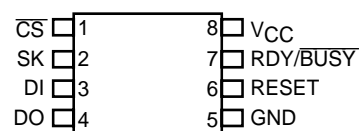

SOIC Package (S, V)

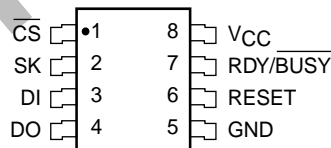

TSSOP Package (UR, YR)

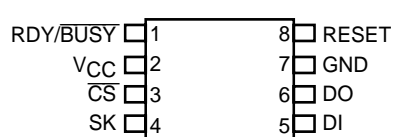

PIN FUNCTIONS

| Pin Name | Function |
|-----------------|-----------------------------|
| CS | Chip Select |
| SK | Clock Input |
| DI | Serial Data Input |
| DO | Serial Data Output |
| V _{CC} | +2.5V to +6.0V Power Supply |
| GND | Ground |
| RESET | Reset |
| RDY/BSY | Ready/BUSY Status |

BLOCK DIAGRAM

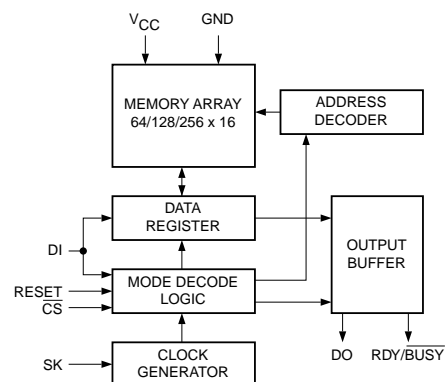

64LC10/20/40 F02

ABSOLUTE MAXIMUM RATINGS*

Temperature Under Bias -55°C to +125°C
 Storage Temperature -65°C to +150°C
 Voltage on any Pin with
 Respect to Ground⁽¹⁾ -2.0V to +V_{CC} +2.0V
 V_{CC} with Respect to Ground -2.0V to +7.0V
 Package Power Dissipation
 Capability (T_a = 25°C) 1.0W
 Lead Soldering Temperature (10 secs) 300°C
 Output Short Circuit Current⁽²⁾ 100 mA

***COMMENT**

Stresses above those listed under “Absolute Maximum Ratings” may cause permanent damage to the device. These are stress ratings only, and functional operation of the device at these or any other conditions outside of those listed in the operational sections of this specification is not implied. Exposure to any absolute maximum rating for extended periods may affect device performance and reliability.

RELIABILITY CHARACTERISTICS

| Symbol | Parameter | Min. | Max. | Units | Reference Test Method |
|------------------------------------|--------------------|-----------|------|-------------|-------------------------------|
| N _{END} ⁽³⁾ | Endurance | 1,000,000 | | Cycles/Byte | MIL-STD-883, Test Method 1033 |
| T _{DR} ⁽³⁾ | Data Retention | 100 | | Years | MIL-STD-883, Test Method 1008 |
| V _{ZAP} ⁽³⁾ | ESD Susceptibility | 2000 | | Volts | MIL-STD-883, Test Method 3015 |
| I _{LTH} ⁽³⁾⁽⁴⁾ | Latch-Up | 100 | | mA | JEDEC Standard 17 |

CAPACITANCE (T_A = 25°C, f = 1.0 MHz, V_{CC} = 6.0V)

| Symbol | Test | Max. | Units | Conditions |
|---------------------------------|--|------|-------|-----------------------|
| C _{I/O} ⁽³⁾ | Input/Output Capacitance (DO, RDY/BSY) | 8 | pF | V _{I/O} = 0V |
| C _{IN} ⁽³⁾ | Input Capacitance (\overline{CS} , SK, DI, RESET) | 6 | pF | V _{IN} = 0V |

Note:

- (1) The minimum DC input voltage is -0.5V. During transitions, inputs may undershoot to -2.0V for periods of less than 20 ns. Maximum DC voltage on output pins is V_{CC} +0.5V, which may overshoot to V_{CC} +2.0V for periods of less than 20 ns.
- (2) Output shorted for no more than one second. No more than one output shorted at a time.
- (3) This parameter is tested initially and after a design or process change that affects the parameter.
- (4) Latch-up protection is provided for stresses up to 100 mA on address and data pins from -1V to V_{CC} +1V.

D.C. OPERATING CHARACTERISTICS

$V_{CC} = +2.5V$ to $+6.0V$, unless otherwise specified.

| Sym. | Parameter | | Limits | | | Units | Test Conditions |
|--------------------------------|--|------|---------------------|------|---------------------|-------|---|
| | | | Min. | Typ. | Max. | | |
| I _{CC} | Operating Current | 2.5V | | | 0.4 | mA | f _{SK} = 250 kHz |
| | EWEN, EWDS, READ | 6.0V | | | 1 | mA | f _{SK} = 1 MHz |
| I _{CCP} | Program Current | 2.5V | | | 2 | mA | |
| | | 6.0V | | | 3 | mA | |
| I _{SB} ⁽¹⁾ | Standby Current | | | | 3 | μA | $V_{IN} = GND$ or V_{CC} $CS = V_{CC}$ |
| I _{LI} | Input Leakage Current | | | | 2 | μA | $V_{IN} = GND$ to V_{CC} |
| I _{LO} | Output Leakage Current | | | | 10 | μA | $V_{OUT} = GND$ to V_{CC} |
| V _{IL} | Low Level Input Voltage, DI | | -0.1 | | $V_{CC} \times 0.3$ | V | |
| V _{IH} | High Level Input Voltage, DI | | $V_{CC} \times 0.7$ | | $V_{CC} + 0.5$ | V | |
| V _{IL} | Low Level Input Voltage, CS, SK, RESET | | -0.1 | | $V_{CC} \times 0.2$ | V | |
| V _{IH} | High Level Input Voltage, CS, SK, RESET | | $V_{CC} \times 0.8$ | | $V_{CC} + 0.5$ | V | |
| V _{OH} ⁽¹⁾ | High Level Output Voltage | 2.5V | $V_{CC} - 0.3$ | | | V | I _{OH} = -10μA |
| | | 6.0V | $V_{CC} - 0.3$ | | | V | I _{OH} = -10μA |
| | | | 2.4 | | | V | I _{OH} = -400μA |
| V _{OL} ⁽¹⁾ | Low Level Output Voltage | 2.5V | | | 0.4 | V | I _{OL} = 10μA |
| | | 6.0V | | | 0.4 | V | I _{OL} = 2.1mA |

Note:

(1) V_{OH} and V_{OL} spec applies to READY/BUSY pin also

A.C. OPERATING CHARACTERISTICS

V_{CC} = +2.5V to +6.0V, unless otherwise specified.

| Symbol | Parameter | Limits | | | Units |
|--------------------------------|-------------------------------------|-----------|------|------|-------|
| | | Min. | Typ. | Max. | |
| t _{CSS} | \overline{CS} Setup Time | 100 | | | ns |
| t _{CSH} | \overline{CS} Hold Time | 100 | | | ns |
| t _{DIS} | DI Setup Time | 200 | | | ns |
| t _{DIH} | DI Hold Time | 200 | | | ns |
| t _{PD1} | Output Delay to 1 | | | 300 | ns |
| t _{PD0} | Output Delay to 0 | | | 300 | ns |
| t _{HZ} ⁽²⁾ | Output Delay to High Impedance | | | 500 | ns |
| t _{CSMIN} | Minimum \overline{CS} High Time | 250 | | | ns |
| t _{SKHI} | Minimum SK High Time | 2.5V | 1000 | | ns |
| | | 4.5V–6.0V | 400 | | |
| t _{SKLOW} | Minimum SK Low Time | 2.5V | 1000 | | ns |
| | | 4.5V–6.0V | 400 | | |
| t _{SV} | Output Delay to Status Valid | | | 500 | ns |
| f _{SK} | Maximum Clock Frequency | 2.5V | 250 | | kHz |
| | | 4.5V–6.0V | 1000 | | |
| t _{RESS} | Reset to \overline{CS} Setup Time | 0 | | | ns |
| t _{RESMIN} | Minimum RESET High Time | 250 | | | ns |
| t _{RESH} | RESET to READY Hold Time | 0 | | | ns |
| t _{RC} | Write Recovery | 100 | | | ns |

POWER-UP TIMING⁽¹⁾⁽³⁾

| Symbol | Parameter | Min. | Max. | Units |
|------------------|-------------------------------|------|------|-------|
| t _{PUR} | Power-Up to Read Operation | | 10 | μs |
| t _{PUW} | Power-Up to Program Operation | | 1 | ms |

WRITE CYCLE LIMITS

| Symbol | Parameter | Min. | Max. | Units |
|-----------------|--------------------|-----------|------|-------|
| t _{WR} | Program Cycle Time | 2.5V | 10 | ms |
| | | 4.5V–6.0V | 5 | |

Note:

- (1) This parameter is tested initially and after a design or process change that affects the parameter.
- (2) This parameter is sampled but not 100% tested.
- (3) t_{PUR} and t_{PUW} are the delays required from the time V_{CC} is stable until the specified operation can be initiated.

INSTRUCTION SET

| Instruction | | Opcode | Address | Data |
|--------------------------------------|--------|----------|-------------------------|----------|
| Read | 64LC10 | 10101000 | A5 A4 A3 A2 A1 A0 0 0 | D15 - D0 |
| | 64LC20 | 10101000 | A6 A5 A4 A3 A2 A1 A0 0 | D15 - D0 |
| | 64LC40 | 10101000 | A7 A6 A5 A4 A3 A2 A1 A0 | D15 - D0 |
| Write | 64LC10 | 10100100 | A5 A4 A3 A2 A1 A0 0 0 | D15 - D0 |
| | 64LC20 | 10100100 | A6 A5 A4 A3 A2 A1 A0 0 | D15 - D0 |
| | 64LC40 | 10100100 | A7 A6 A5 A4 A3 A2 A1 A0 | D15 - D0 |
| Write Enable | | 10100011 | X X X X X X X X | |
| Write Disable | | 10100000 | X X X X X X X X | |
| [Write All Locations] ⁽¹⁾ | | 10100001 | X X X X X X X X | D15-D0 |

Figure 1. A.C. Testing Input/Output Waveform ⁽²⁾⁽³⁾⁽⁴⁾ ($C_L = 100 \text{ pF}$)

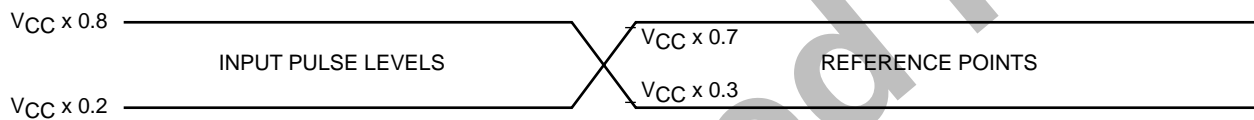

Note:

- (1) [Write All Locations] is a test mode operation and is therefore not included in the A.C./D.C. Operations specifications.
- (2) Input Rise and Fall Times (10% to 90%) < 10 ns.
- (3) Input Pulse Levels = $V_{CC} \times 0.2$ and $V_{CC} \times 0.8$.
- (4) Input and Output Timing Reference = $V_{CC} \times 0.3$ and $V_{CC} \times 0.7$.

DEVICE OPERATION

The CAT64LC10/20/40 is a 1K/2K/4K-bit nonvolatile memory intended for use with all standard controllers. The CAT64LC10/20/40 is organized in a 64/128/256 x 16 format. All instructions are based on an 8-bit format. There are four 16-bit instructions: READ, WRITE, EWEN, and EWDS. The CAT64LC10/20/40 operates on a single power supply ranging from 2.5V to 6.0V and it has an on-chip voltage generator to provide the high voltage needed during a programming operation. Instructions, addresses

and data to be written are clocked into the DI pin on the rising edge of the SK clock. The DO pin is normally in a high impedance state except when outputting data in a READ operation or outputting RDY/BSY status when polled during a WRITE operation.

The format for all instructions sent to this device includes a 4-bit start sequence, 1010, a 4-bit op code and an 8-bit address field or dummy bits. For a WRITE operation,

Figure 2. Synchronous Data Timing

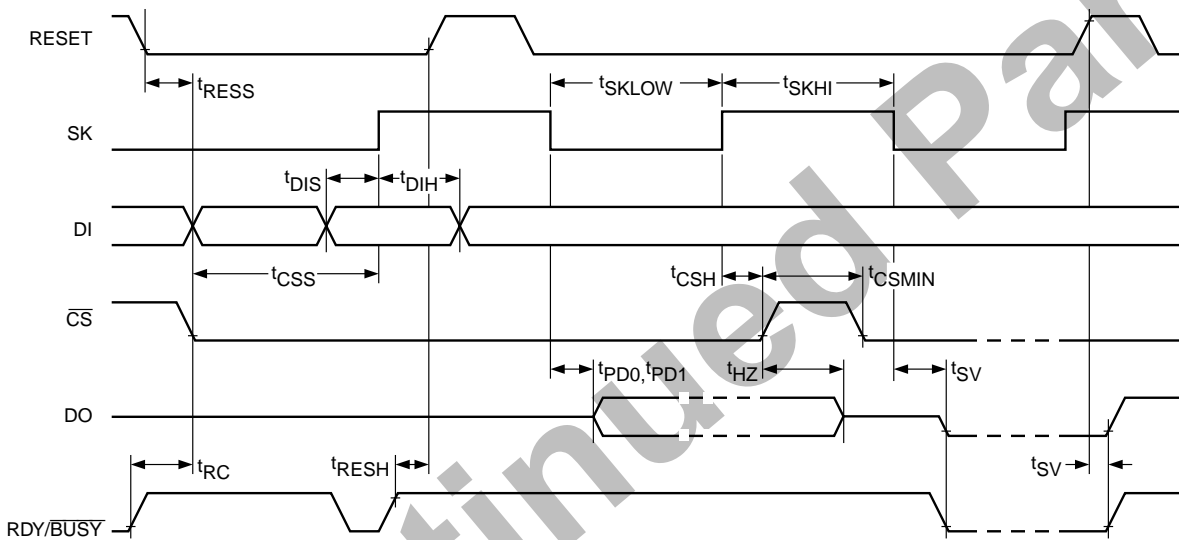
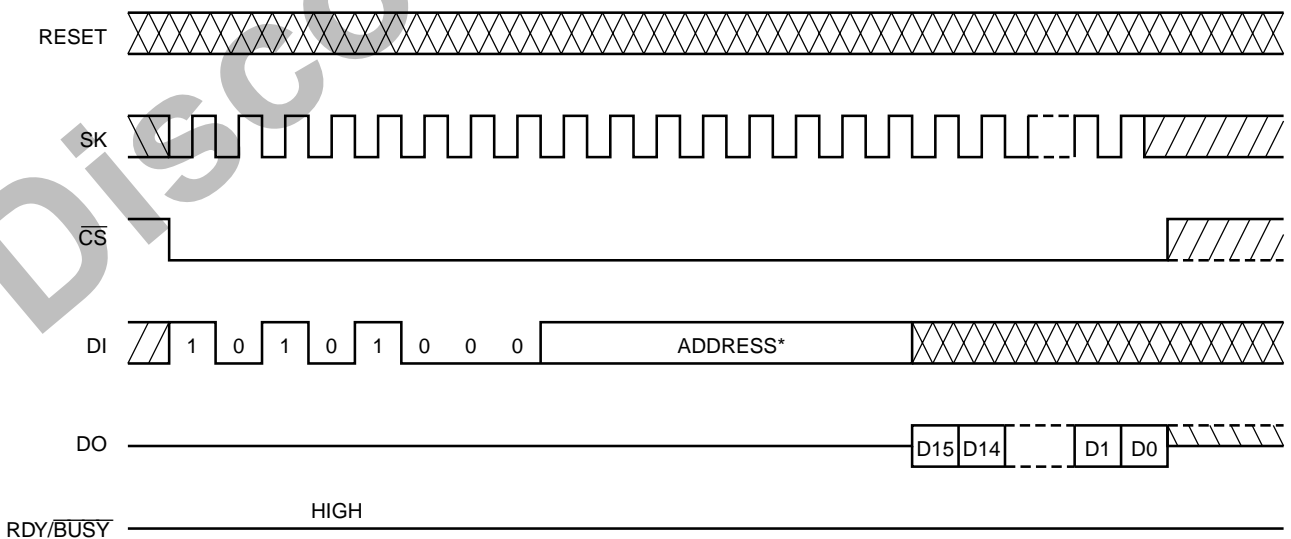

Figure 3. Read Instruction Timing



* Please check the instruction set table for address

a 16-bit data field is also required following the 8-bit address field.

The CAT64LC10/20/40 requires an active LOW \overline{CS} in order to be selected. Each instruction must be preceded by a HIGH-to-LOW transition of \overline{CS} before the input of the 4-bit start sequence. Prior to the 4-bit start sequence (1010), the device will ignore inputs of all other logical sequence.

Read

Upon receiving a READ command and address (clocked into the DI pin), the DO pin will output data one t_{PD} after the falling edge of the 16th clock (the last bit of the address field). The READ operation is not affected by the RESET input.

Write

After receiving a WRITE op code, address and data, the device goes into the AUTO-Clear cycle and then the

Figure 4. Write Instruction Timing

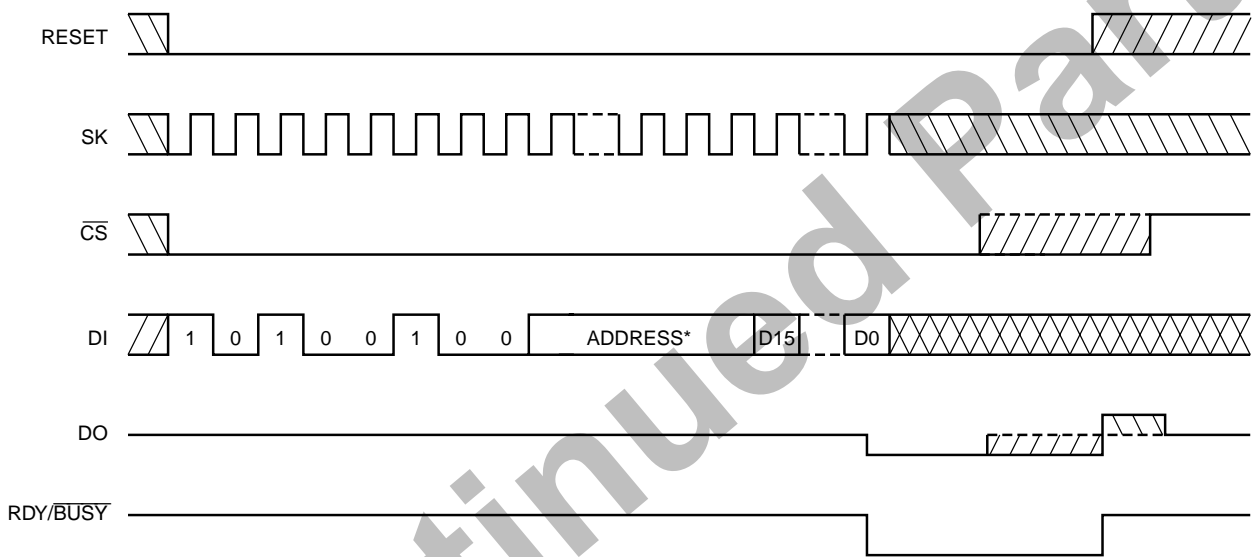

* Please check instruction set table for address

Figure 5. Ready/BUSY Status Instruction Timing

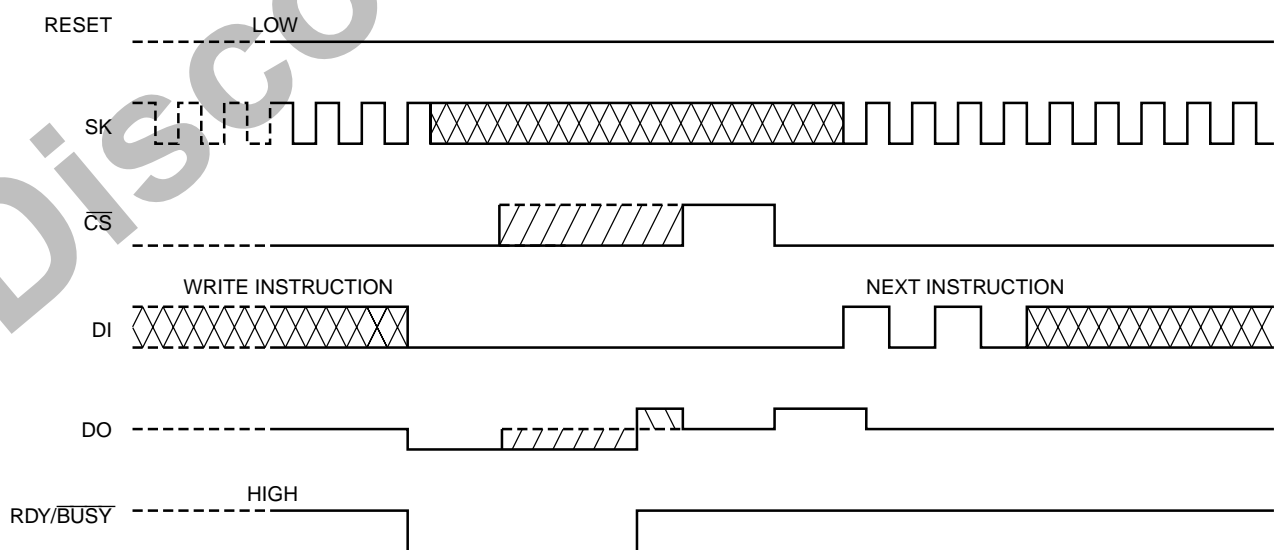

WRITE cycle. The RDY/ $\overline{\text{BSY}}$ pin will output the $\overline{\text{BUSY}}$ status (LOW) one t_{SV} after the rising edge of the 32nd clock (the last data bit) and will stay LOW until the write cycle is complete. Then it will output a logical "1" until the next WRITE cycle. The RDY/ $\overline{\text{BSY}}$ output is not affected by the input of $\overline{\text{CS}}$.

An alternative to get RDY/ $\overline{\text{BSY}}$ status is from the DO pin. During a write cycle, asserting a LOW input to the $\overline{\text{CS}}$ pin will cause the DO pin to output the RDY/ $\overline{\text{BSY}}$ status. Bringing $\overline{\text{CS}}$ HIGH will bring the DO pin back to a high impedance state again. After the device has completed a WRITE cycle, the DO pin will output a logical "1" when

the device is deselected. The rising edge of the first "1" input on the DI pin will reset DO back to the high impedance state again.

The WRITE operation can be halted anywhere in the operation by the RESET input. If a RESET pulse occurs during a WRITE operation, the device will abort the operation and output a READY status.

NOTE: Data may be corrupted if a RESET occurs while the device is $\overline{\text{BUSY}}$. If the reset occurs before the $\overline{\text{BUSY}}$ period, no writing will be initiated. However, if RESET occurs after the $\overline{\text{BUSY}}$ period, new data will have been written over the old data.

Figure 6. RESET During $\overline{\text{BUSY}}$ Instruction Timing

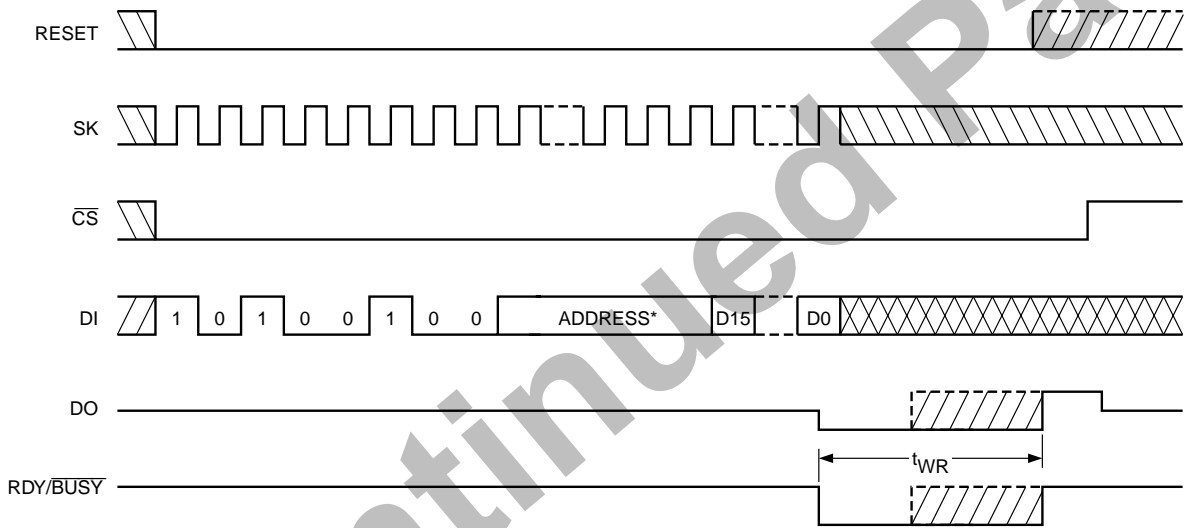

* Please check instruction set table for address

Figure 7. EWEN Instruction Timing

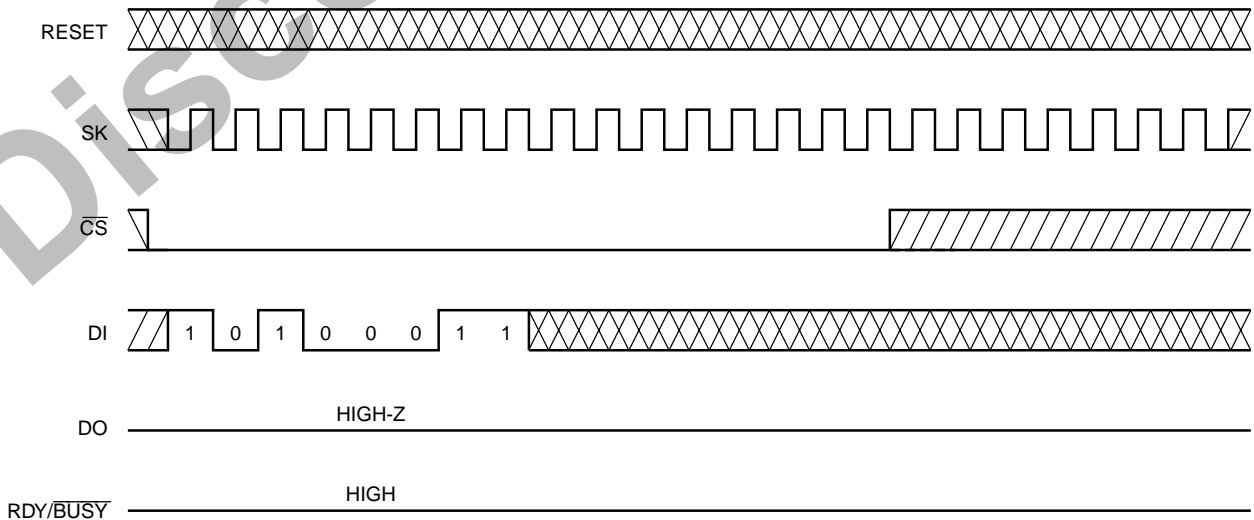

RESET

The RESET pin, when set to HIGH, will reset or abort a WRITE operation. When RESET is set to HIGH while the WRITE instruction is being entered, the device will not execute the WRITE instruction and will keep DO in High-Z condition.

When RESET is set to HIGH, while the device is in a clear/write cycle, the device will abort the operation and will display READY status on the RDY/BSY pin and on the DO pin if CS is low.

The RESET input affects only the WRITE and WRITE ALL operations. It does not reset any other operations such as READ, EWEN and EWDS.

ERASE/WRITE ENABLE and DISABLE

The CAT64LC10/20/40 powers up in the erase/write disabled state. After power-up or while the device is in an erase/write disabled state, any write operation must be preceded by an execution of the EWEN instruction. Once enabled, the device will stay enabled until an EWDS has been executed or a power-down has occurred. The EWDS is used to prevent any inadvertent overwriting of the data. The EWEN and EWDS instructions have no effect on the READ operation and are not affected by the RESET input.

Figure 8. EWDS Instruction Timing

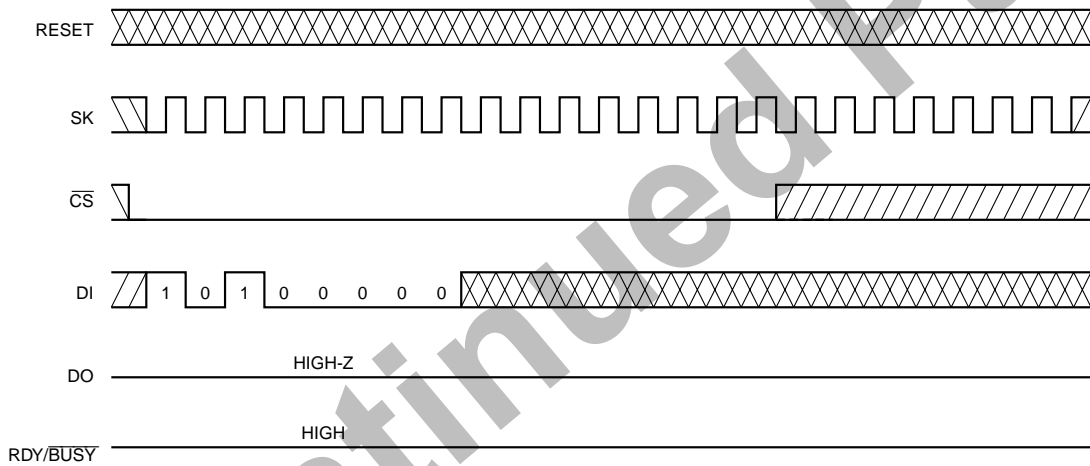

ORDERING INFORMATION

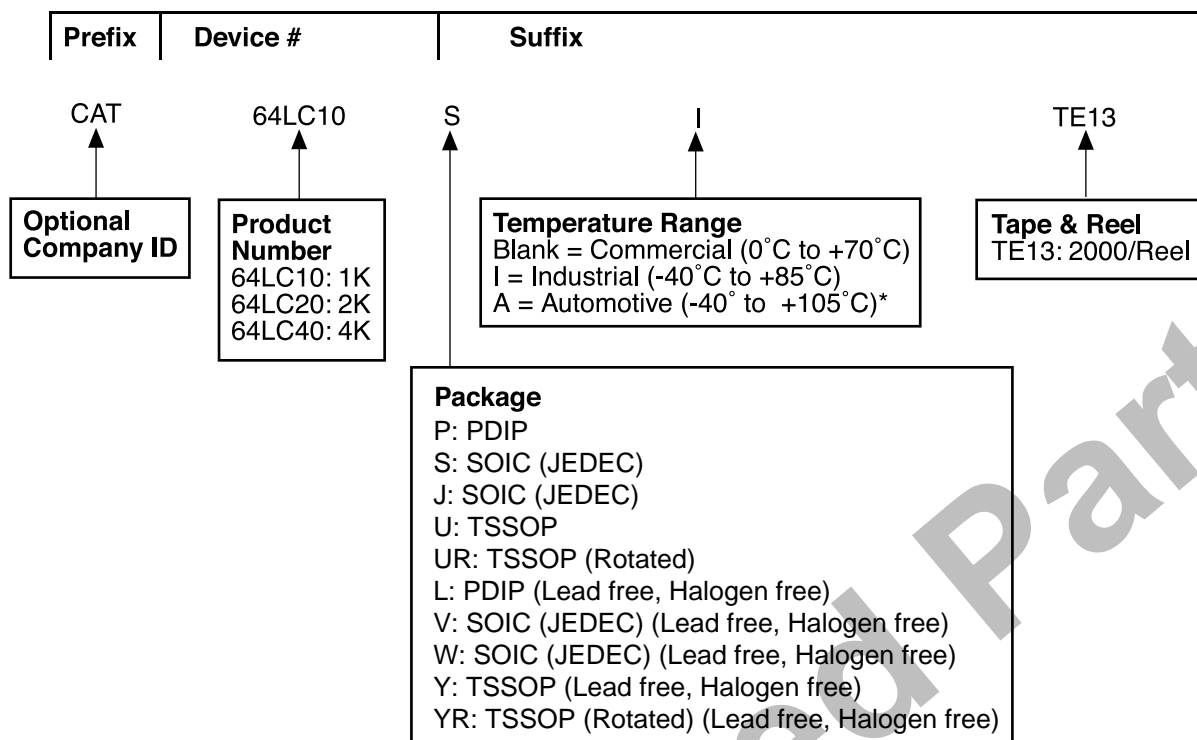

* -40°C to +125°C is available upon request

Notes:

(1) The device used in the above example is a 64LC10SI-TE13 (SOIC, Industrial Temperature, Tape & Reel)

Discontinued Parts

PACKAGING INFORMATION
8-LEAD TSSOP (U)

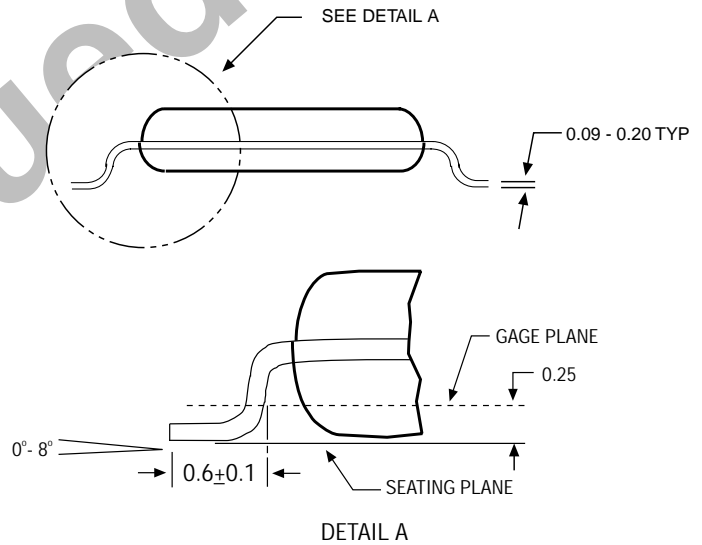
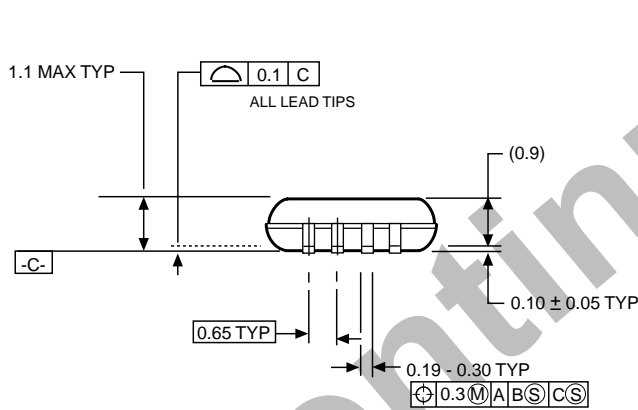
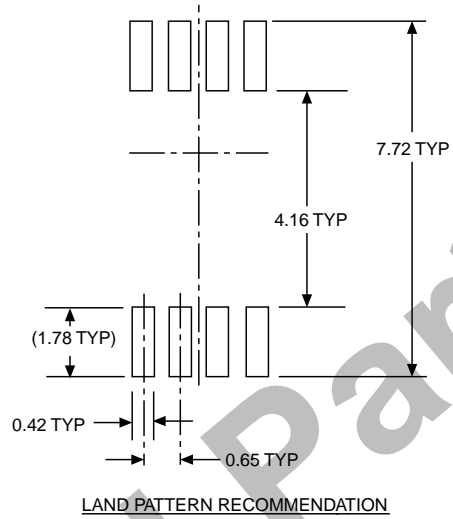
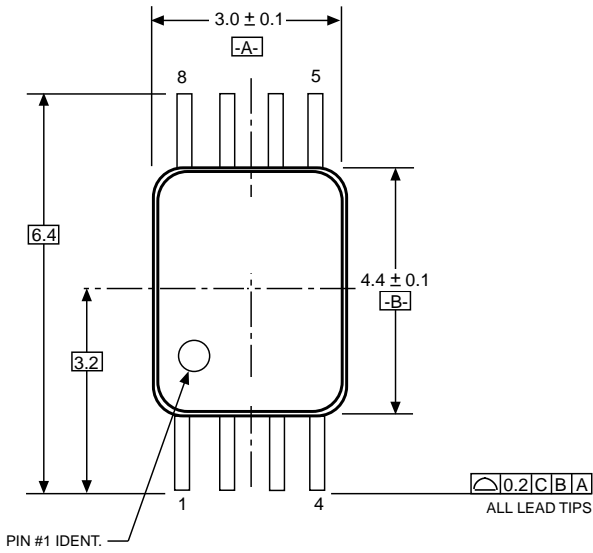

Discontinued in Ueda Parts

REVISION HISTORY

| Date | Rev. | Reason |
|------------|------|--|
| 9/3/2004 | B | Added Green packages in all areas Updated DC Operating Characteristics table & notes |
| 11/17/2004 | C | Changed I_{SB} from $1\mu A$, Max to $3\mu A$, Max in DC Operating Characteristics table |

Copyrights, Trademarks and Patents

Trademarks and registered trademarks of Catalyst Semiconductor include each of the following:

DPP™ AE²™

Catalyst Semiconductor has been issued U.S. and foreign patents and has patent applications pending that protect its products. For a complete list of patents issued to Catalyst Semiconductor contact the Company's corporate office at 408.542.1000.

CATALYST SEMICONDUCTOR MAKES NO WARRANTY, REPRESENTATION OR GUARANTEE, EXPRESS OR IMPLIED, REGARDING THE SUITABILITY OF ITS PRODUCTS FOR ANY PARTICULAR PURPOSE, NOR THAT THE USE OF ITS PRODUCTS WILL NOT INFRINGE ITS INTELLECTUAL PROPERTY RIGHTS OR THE RIGHTS OF THIRD PARTIES WITH RESPECT TO ANY PARTICULAR USE OR APPLICATION AND SPECIFICALLY DISCLAIMS ANY AND ALL LIABILITY ARISING OUT OF ANY SUCH USE OR APPLICATION, INCLUDING BUT NOT LIMITED TO, CONSEQUENTIAL OR INCIDENTAL DAMAGES.

Catalyst Semiconductor products are not designed, intended, or authorized for use as components in systems intended for surgical implant into the body, or other applications intended to support or sustain life, or for any other application in which the failure of the Catalyst Semiconductor product could create a situation where personal injury or death may occur.

Catalyst Semiconductor reserves the right to make changes to or discontinue any product or service described herein without notice. Products with data sheets labeled "Advance Information" or "Preliminary" and other products described herein may not be in production or offered for sale.

Catalyst Semiconductor advises customers to obtain the current version of the relevant product information before placing orders. Circuit diagrams illustrate typical semiconductor applications and may not be complete.



CATALYST

Catalyst Semiconductor, Inc.
Corporate Headquarters
1250 Borregas Avenue
Sunnyvale, CA 94089
Phone: 408.542.1000
Fax: 408.542.1200
www.catalyst-semiconductor.com

Publication #: 1021
Revision: C
Issue date: 11/3/04