



High Current, Surface Mount Inductor



FEATURES

- High energy storage.
- Low resistance.
- Tape and reel packaging for automatic handling.

ELECTRICAL SPECIFICATIONS

Inductance Range: 1.0 μ H to 68 μ H.

Inductance Tolerance: 20%.

Operating Temperature: - 25°C to + 105°C.

Storage Temperature: - 40°C to 125°C.

Resistance to Solder Heat: 260°C for 10 seconds.

MATERIALS

Core: Ferrite.

Wire: Enamelled copper wire.

Terminal: Ag + Ni + Sn/Pb.

STANDARD ELECTRICAL SPECIFICATIONS

INDUCTANCE (μ H)	TEST FREQUENCY L	DCR MAXIMUM (Ohms)	RATED DC CURRENT* (A)
1.0	7.96MHz	0.033	3.80
1.4	7.96MHz	0.038	3.30
1.8	7.96MHz	0.042	2.91
2.2	7.96MHz	0.047	2.60
2.7	7.96MHz	0.052	2.43
3.3	7.96MHz	0.058	2.15
3.9	7.96MHz	0.076	1.98
4.7	7.96MHz	0.094	1.70
5.6	7.96MHz	0.101	1.60
6.8	7.96MHz	0.117	1.41
8.2	7.96MHz	0.132	1.26
10.0	2.52MHz	0.182	1.15
12.0	2.52MHz	0.210	1.05
15.0	2.52MHz	0.235	0.92
18.0	2.52MHz	0.338	0.84
22.0	2.52MHz	0.378	0.76
27.0	2.52MHz	0.522	0.71
33.0	2.52MHz	0.540	0.64
39.0	2.52MHz	0.587	0.59
47.0	2.52MHz	0.844	0.54
56.0	2.52MHz	0.937	0.50
68.0	2.52MHz	1.117	0.46

*Rated Current: Value obtained when current flows and the temperature has risen 40°C or when DC current flows and the initial value of inductance has fallen by 10%, whichever is smaller.

DIMENSIONS in inches [millimeters]

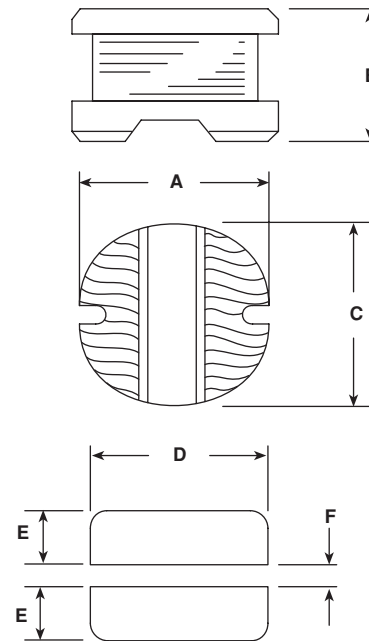

TYPICAL PAD LAYOUT

A	B	C
0.178 \pm 0.01 [4.5 \pm 0.3]	0.126 \pm 0.01 [3.2 \pm 0.3]	0.158 \pm 0.01 [4.0 \pm 0.3]
D	E	F
0.178 [4.5]	0.069 [1.75]	0.059 [1.5]

DESCRIPTION

IDCP-1813	10 μ H	\pm 20%
MODEL	INDUCTANCE VALUE	INDUCTANCE TOLERANCE

SAP PART NUMBERING GUIDELINES (INTERNAL)

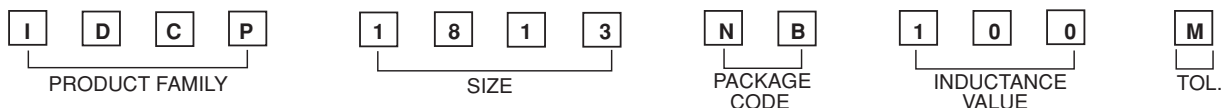

See the end of this data book for conversion tables