

1			2			3			4			5			6			7			8		
REVISIONS																							
ISS	ZONE	DESCRIPTION\PER REQUEST\DATE																					

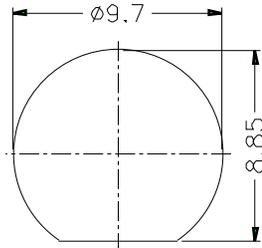

1. MAX. PANEL THICKNESS=3.2mm

RECOMMENDED MOUNTING HOLE

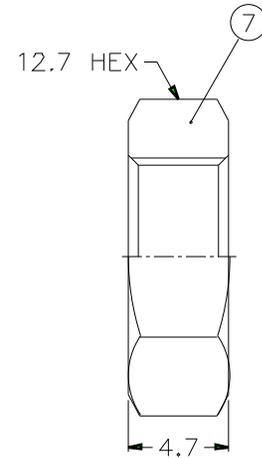
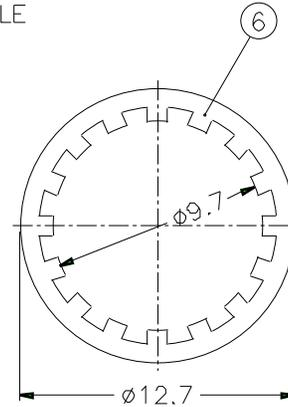
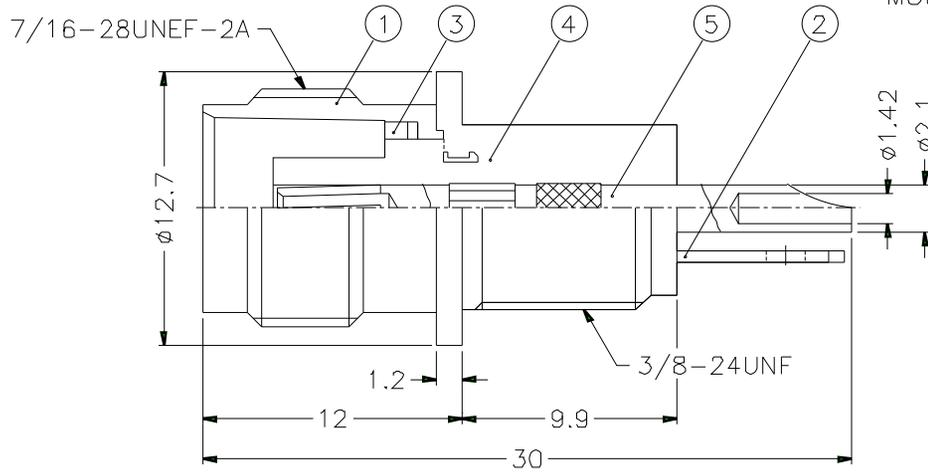

NOTES: FINISH (PLATING THICKNESS IN MICRO-INCHES)

1. BRASS PER QQ-B-626
2. BRASS PER QQ-B-613
3. NICKEL PL. 100 MIN. THICK OVER COPPER STRIKE
4. PHOSPHOR BRONZE PER QQ-B-750
5. GOLD PL. 3 MIN. THICK OVER NICKEL PL. 100 MIN. THICK OVER COPPER STRIKE
6. BRIGHT TIN PL. 200 MIN. THICK OVER NICKEL PL. 50 MIN. THICK OVER COPPER PL. 100 MIN. THICK

RECOMMENDED TORQUE: A MAXIMUM TORQUE OF 12 INCH-LBS MAY BE APPLIED ON HEX NUT WHEN MOUNTING CONNECTOR IN PANEL.

7	HEX NUT	NOTE 1	NOTE 3	1	HN127-3/8-24X47
6	LOCK WASHER	NOTE 2	NOTE 3	1	LW-127/97X05
5	CONTACT PIN	NOTE 4	NOTE 5	1	B7300-5
4	INSULADR	NYLON	WHITE	1	T6651B1-1-50-C
3	LOCK RING	NOTE 2	NOTE 3	1	
2	BRAID GROUNDING	NOTE 2	NOTE 6	1	
1	BODY	NOTE 1	NOTE 3	1	
NO.	DESCRIPTION	MATERIAL	FINISH	Q'TY	DRAWING NO.

DIMENSIONS ARE IN MILLIMETERS
UNLESS OTHERWISE SPECIFIED TOLERANCES
0.5-6 = ±0.2
6-30 = ±0.4
30-120 = ±0.6
120-315 = ±1
315-1000 = ±1.6
1000-2000 = ±2.4

PART NO.	T6651B1-NNYL3G-50
APPROVED	DATE 10-11-01'
CHECKED	DATE 10-11-01'
DRAWN	DATE 10-11-01'
FILE NO	

Amphenol	
TITLE TNC BULKHEAD RECEPT. ISOLATED JACK	
DRAWING NO. KJ-T6651B1-NNYL3G-50	
ITEM NO.	

1		2		3		4		5		6		7		8	
---	--	---	--	---	--	---	--	---	--	---	--	---	--	---	--