

SMS SERIES - 12 WATT

DESCRIPTION

SMS surface-mountable DC/DC converters feature up to 12 Watts of output power. The SMS is a fully isolated converter with 1500 VDC isolation, short circuit, and undervoltage lockout protection. The SMS is available with remote shutdown, as well as an optional active current share, to allow for high power distributed operation. Available in 24 or 48 VDC input versions, the SMS is well suited to telecom and networking applications.

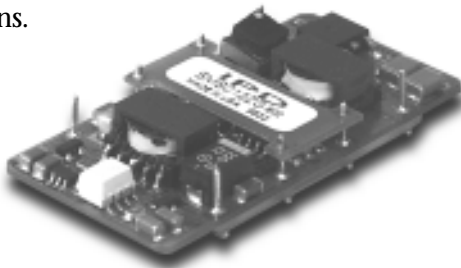

FEATURES

- Industry Standard Package
- Industry Standard Pinout
- 85°C Case Operation
- Short Circuit Protection
- 6-Sided Shielding
- 24V and 48V Input Versions
- Input Pi Filter
- Regulated Outputs
- 1500V Isolation

TECHNICAL SPECIFICATIONS

Input	
Voltage Range	
24 VDC Nominal	18 - 36 VDC
48 VDC Nominal	36 - 72 VDC
Reflected Ripple	25 mA
Input Reverse Voltage Protection	Shunt Diode

Output	
Setpoint Accuracy	±1%
Line Regulation V_{in} Min. - V_{in} Max., I_{out} Rated	±0.1% V_{out}
Load Regulation I_{out} Min. - I_{out} Max., V_{in} Nom	±0.2% V_{out}
Minimum Output Current	10 % I_{out} Rated
Dynamic Regulation, Loadstep	25% I_{out}
Pk Deviation	4% V_{out}
Settling Time	500 μ s
Short Circuit / Overcurrent Protection	Shutdown / Hiccup
Current Limit Threshold Range, % of I_{out} Rated	110 - 130%

General	
Turn-On Time	10 ms
Remote Shutdown	Positive Logic
Switching Frequency	400 kHz
Isolation	
Input - Output	1500 VDC
Temperature Coefficient	±0.03%/°C
Operating Temperature	
Ambient Operating Range 100 LFM	-40 To +85°C
Ambient Operating Range Convection	-40 To +70°C
Storage Range	-40 To +100°C
Humidity Max., Non-Condensing	95%
Vibration, 3 Axes, 5 Min Each	5 g, 10 - 55 Hz
MTBF ¹ (Bellcore TR-NWT-000332)	Consult Factory
Safety	Consult Factory
Weight (approx.)	0.4 oz

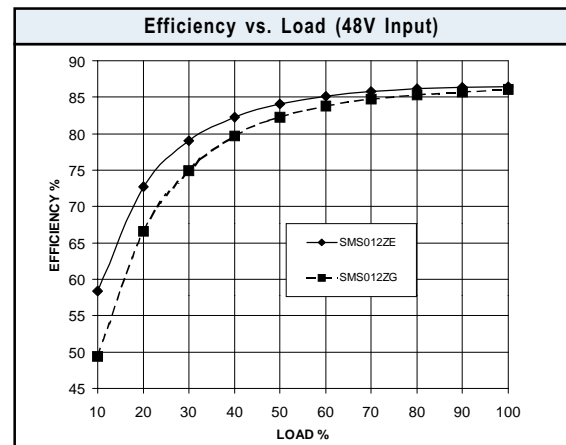
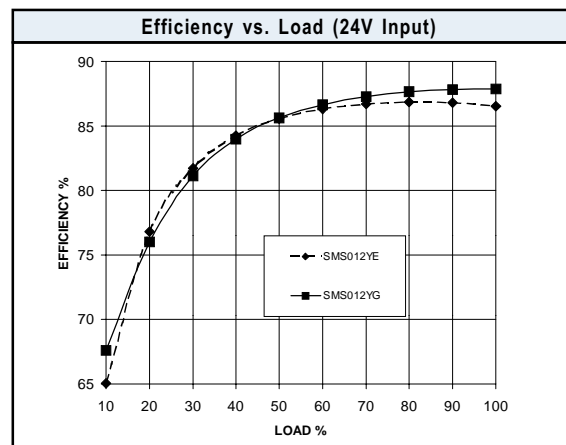

Notes
¹ MTBF predictions may vary slightly from model to model.
Specifications typically at 25°C, normal line, and full load, unless otherwise stated.
Soldering Conditions: I/O pins, 260°C, ten seconds; fully compatible with commercial wave-soldering equipment.
Safety: Agency approvals may vary from model to model. Please consult factory for specific model information.
Units are water-washable and fully compatible with commercial spray or immersion post wave-solder washing equipment.

SMS SERIES - 12 WATT

MODELS - (See the last page of this file for options.)

V _{in} (Volts)	V _{in} Range (Volts)	I _{in} Max* (Amps)	V _{out} (Volts)	I _{out} Rated (Amps)	Ripple & Noise Pk-Pk (mV)	Efficiency Typ. **	Model
24	18 - 36	0.52	2.1	3.3	50	84%	SMS007YC
24	18 - 36	0.64	2.5	3.6	50	86%	SMS009YD
24	18 - 36	0.82	3.3	3.6	50	86%	SMS012YE
24	18 - 36	0.82	5.0	2.4	50	88%	SMS012YG
48	36 - 72	0.26	2.1	3.3	50	82%	SMS007ZC
48	36 - 72	0.32	2.5	3.6	50	85%	SMS009ZD
48	36 - 72	0.41	3.3	3.6	50	87%	SMS012ZE
48	36 - 72	0.41	5.0	2.4	50	88%	SMS012ZG

* Maximum input current at minimum input voltage, maximum rated output power.

** At nominal V_{in}, rated output.

MECHANICAL DRAWING

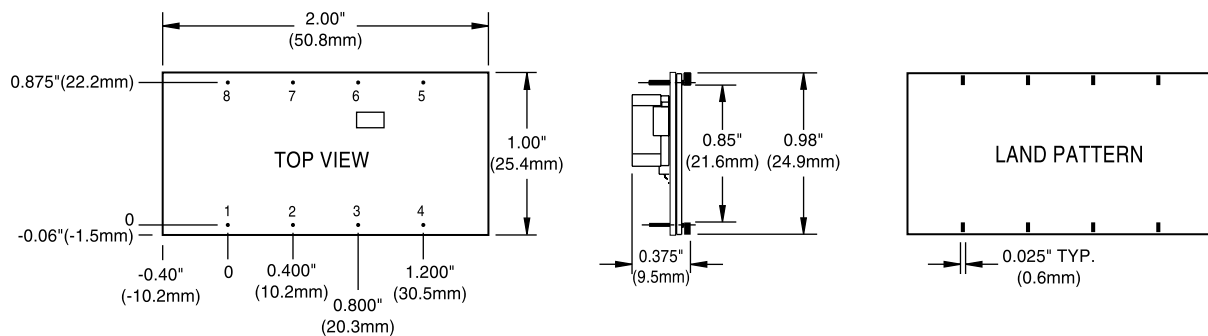

Thermal Impedance	
Natural Convection	21.1 °C/W
100 LFM	10.4 °C/W
200 LFM	6.8 °C/W
300 LFM	5.6 °C/W
400 LFM	4.3 °C/W

Note:
Thermal impedance data is dependent on many environmental factors. The exact thermal performance should be validated for specific application.

Pin	Function
1	-V _{in}
2	S/D
3	+V _{out}
4	-V _{out}
5	-V _{out}
6	+V _{out}
7	OPTION
8	+V _{in}

Tolerances	
Inches:	(Millimeters)
.XX ± 0.020	.X ± 0.5
.XXX ± 0.010	.XX ± 0.25
Pin:	
± 0.002	± 0.05

(Dimensions as listed unless otherwise specified.)

OPTIONS

When ordering equipment options, use the following suffix information. Select the option(s) that you prefer and add them to the model number. Example ordering options are located below the options table.

OPTION	SUFFIX	APPLICABLE SERIES	REMARKS
Negative Logic	N	HAS, HBD, HBS, HES, LES, QBS, QES, TES, TQD	TTL "Low" Turns Module ON TTL "High" Turns Module OFF
Lucent Compatible Trim	T	HAS, HBD, HBS, HES, QBS, QES	
Terminal Strip	TS	XWS	
Trim	1	IAS, LES	
Enable	2	IAD, IAS, LES, SMS	
Trim and Enable	3	IAS, LES	
Current Share	4	SMS	
Headerless	Y	Encapsulated EWS, IWS, OWS	
PIN LENGTH AND HEATSINK OPTIONS			Standard Pin Length is 0.180" (4.6mm)
0.110" (2.8mm) Pin Length	8	All Units (Except SMS)	
0.150" (3.8mm) Pin Length	9	All Units (Except SMS)	
0.24" (6.1mm) Horizontal Heatsink	1H	All Units (Except DIP, SIP, and SM Packages)	Includes Thermal Pad
0.24" (6.1mm) Vertical Heatsink	1V	All Units (Except DIP, SIP, and SM Packages)	Includes Thermal Pad
0.45" (11.4mm) Horizontal Heatsink	2H	All Units (Except DIP, SIP, and SM Packages)	Includes Thermal Pad
0.45" (11.4mm) Vertical Heatsink	2V	All Units (Except DIP, SIP, and SM Packages)	Includes Thermal Pad
0.95" (24.1mm) Horizontal Heatsink	3H	All Units (Except DIP, SIP, and SM Packages)	Includes Thermal Pad
0.95" (24.1mm) Vertical Heatsink	3V	All Units (Except DIP, SIP, and SM Packages)	Includes Thermal Pad

Example Options: HBS050ZG-ANT3V = HBS050ZG-A with negative logic, Lucent compatible trim, and 0.95" vertical heatsink.

LES015YJ-3N = LES015YJ with optional trim and enable, negative logic.

QBS066ZG-AT8 = QBS066ZG-A with Lucent compatible trim and 0.110" pin length.

NUCLEAR AND MEDICAL APPLICATIONS Power-One products are not authorized for use as critical components in life support systems, equipment used in hazardous environments, or nuclear control systems without the express written consent of the President of Power-One, Inc.

TECHNICAL REVISIONS The appearance of products, including safety agency certifications pictured on labels, may change depending on the date manufactured. Specifications are subject to change without notice.