

Current Transducer LT 1000-SI/SP60

$I_{PN} = 1000 \text{ A}$

For the electronic measurement of currents : DC, AC, pulsed..., with a galvanic isolation between the primary circuit (high power) and the secondary circuit (electronic circuit).

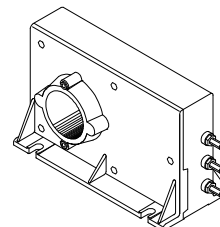

Electrical data

I_{PN}	Primary nominal r.m.s. current	1000	A		
I_p	Primary current, measuring range @ $\pm 24 \text{ V}$	$0 \dots \pm 1800$	A		
R_M	Measuring resistance	$R_{M \min}$	$R_{M \max}$		
				with $\pm 15 \text{ V}$	@ $\pm 1000 \text{ A}_{\max}$
		@ $\pm 1500 \text{ A}_{\max}$	0	3	Ω
	with $\pm 24 \text{ V}$	@ $\pm 1000 \text{ A}_{\max}$	10	65	Ω
	@ $\pm 1800 \text{ A}_{\max}$	10	18	Ω	
I_{SN}	Secondary nominal r.m.s. current	200	mA		
K_N	Conversion ratio	1 : 5000			
V_C	Supply voltage ($\pm 5 \%$)	$\pm 15 \dots 24$	V		
I_C	Current consumption	$45 + I_s$	mA		
V_d	R.m.s. voltage for AC isolation test, 50 Hz, 1 mn	6	kV		

Features

- Closed loop (compensated) current transducer using the Hall effect
- Insulated plastic case recognized according to UL 94-V0.

Special features

- $I_p = 0 \dots \pm 1800 \text{ A}$ (@ $\pm 24 \text{ V}$)
- $V_C = \pm 15 \dots 24$ ($\pm 5 \%$) V
- $T_A = -25^\circ\text{C} \dots +70^\circ\text{C}$
- Hall cell mounted vertically
- Connection to secondary circuit on M5 threaded studs
- Railway equipment.

Accuracy - Dynamic performance data

X_G	Overall accuracy @ $I_{PN}, T_A = 25^\circ\text{C}$	± 0.3	%
e_L	Linearity	< 0.1	%
I_O	Offset current @ $I_p = 0, T_A = 25^\circ\text{C}$	Typ	Max
I_{OT}	Thermal drift of I_O - $25^\circ\text{C} \dots +70^\circ\text{C}$	± 0.2	± 0.4 mA
t_r	Response time ¹⁾ @ 90 % of $I_{P \max}$	< 1	μs
di/dt	di/dt accurately followed	> 50	A/ μs
f	Frequency bandwidth (-1 dB)	DC .. 100	kHz

Advantages

- Excellent accuracy
- Very good linearity
- Low temperature drift
- Optimized response time
- Wide frequency bandwidth
- No insertion losses
- High immunity to external interference
- Current overload capability.

General data

T_A	Ambient operating temperature	$-25 \dots +70$	$^\circ\text{C}$
T_S	Ambient storage temperature	$-40 \dots +85$	$^\circ\text{C}$
R_S	Secondary coil resistance @ $T_A = 70^\circ\text{C}$	40	Ω
m	Mass	0.9	kg
	Standards ²⁾	EN 50155	

Applications

- AC variable speed drives and servo motor drives
- Static converters for DC motor drives
- Battery supplied applications
- Uninterruptible Power Supplies (UPS)
- Switched Mode Power Supplies (SMPS)
- Power supplies for welding applications.

Notes : ¹⁾ With a di/dt of 100 A/ μs
²⁾ A list of corresponding tests is available

Dimensions LT 1000-SI/SP60 (in mm. 1 mm = 0.0394 inch)

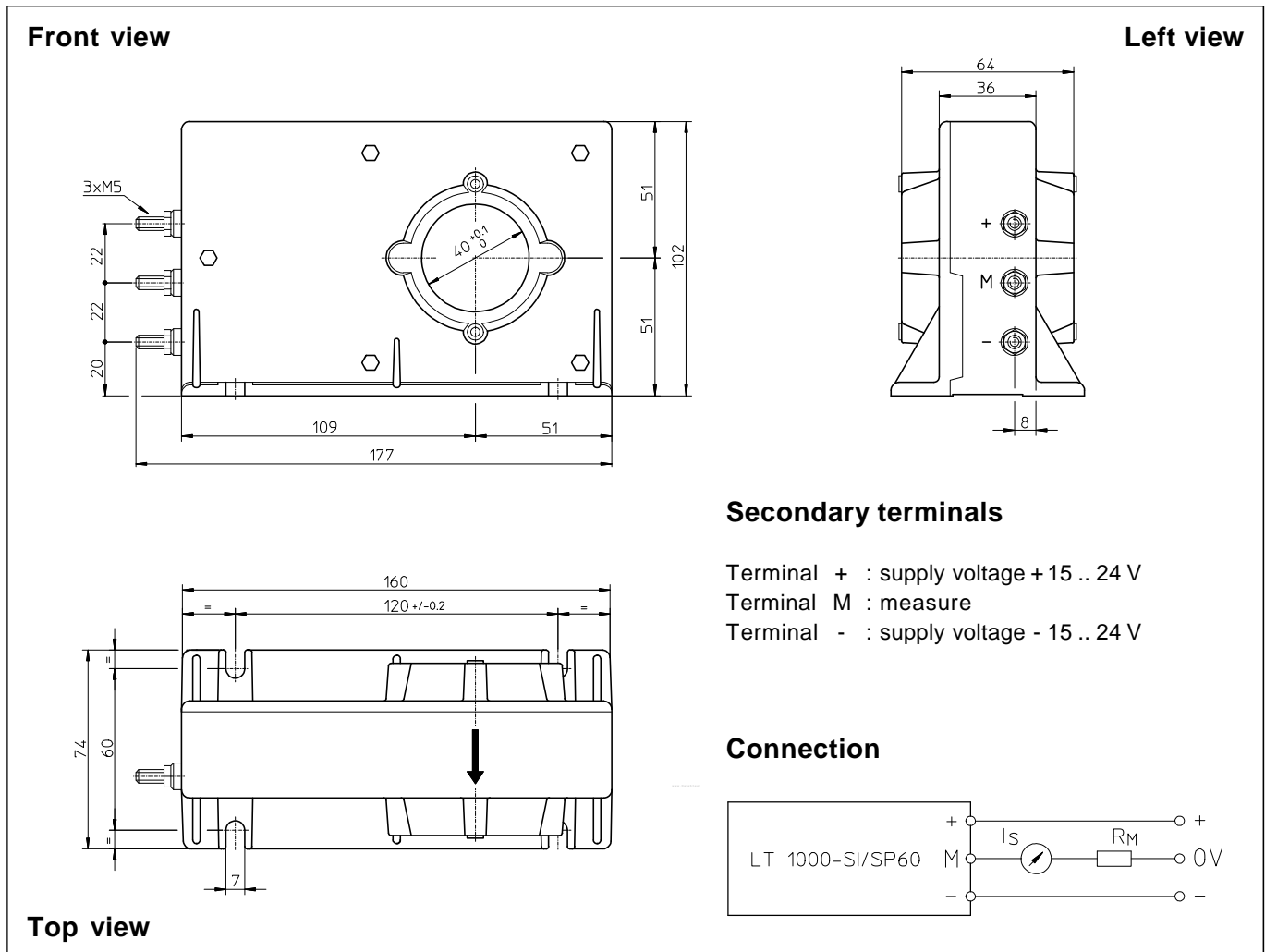

Mechanical characteristics

- General tolerance ± 0.5 mm
- Fastening 4 holes $\varnothing 7$ mm
- Primary through-hole $\varnothing 40$ mm
- Connection of secondary M5 threaded studs
- Fastening torque 2.2 Nm or 1.62 Lb - Ft

Remarks

- I_s is positive when I_p flows in the direction of the arrow.
- Temperature of the primary conductor should not exceed 100°C.
- Dynamic performances (di/dt and response time) are best with a single bar completely filling the primary hole.