

PLEASE CHECK WWW.MOLEX.COM FOR LATEST PART INFORMATION

Part Number: [0873810864](#)
Status: **Active**
Description: 2.00mm (.079") Pitch Milli-Grid™ Receptacle, Surface Mount, Top Entry, 0.38µm (15µ") Gold (Au) Plating, with Cap, without Locating Pegs, 8 Circuits, Lead-free

Documents:

[3D Model](#) [Product Specification PS-87380-002 \(PDF\)](#)
[Drawing \(PDF\)](#) [RoHS Certificate of Compliance \(PDF\)](#)

Agency Certification

CSA LR19980
 UL E29179

General

Product Family PCB Receptacles
 Series [87381](#)
 Application Board-to-Board
 Comments With Cap
 Product Literature Order No 987650-1991
 Product Name Milli-Grid™

Physical

Circuits (Loaded) 8
 Circuits (maximum) 8
 Color - Resin Black
 Durability (mating cycles max) 25
 Flammability 94V-0
 Glow-Wire Compliant No
 Lock to Mating Part None
 Material - Metal Phosphor Bronze
 Material - Plating Mating Gold
 Material - Plating Termination Tin-Lead
 Material - Resin High Temperature Thermoplastic
 Number of Rows 2
 Orientation Vertical
 PCB Locator No
 PCB Retention None
 Packaging Type Tube
 Pitch - Mating Interface (in) 0.079 In
 Pitch - Mating Interface (mm) 2.00 mm
 Pitch - Term. Interface (in) 0.079 In
 Pitch - Term. Interface (mm) 2.00 mm
 Plating min: Mating (µin) 15
 Plating min: Mating (µm) 0.38
 Plating min: Termination (µin) 50
 Plating min: Termination (µm) 1.27
 Polarized to PCB No
 Surface Mount Compatible (SMC) N/A
 Temperature Range - Operating -55°C to +105°C
 Termination Interface: Style Surface Mount

Electrical

Current - Maximum per Contact 1.9A
 Voltage - Maximum 125V

Solder Process Data

Duration at Max. Process Temperature (seconds) 12

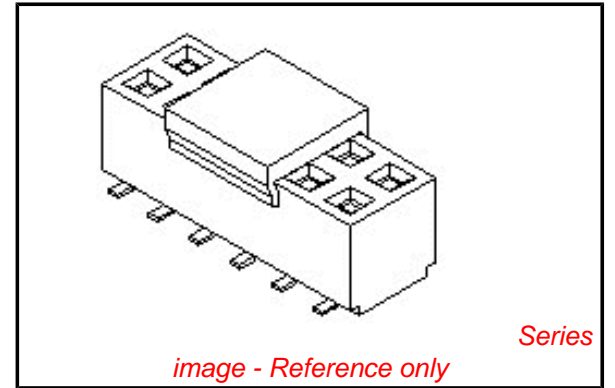

EU RoHS

ELV and RoHS Compliant
REACH SVHC
 Not Reviewed
Halogen-Free Status

China RoHS



Not Halogen-Free

Need more information on product environmental compliance?

Email productcompliance@molex.com
 For a multiple part number RoHS Certificate of Compliance, [click here](#)

Please visit the [Contact Us](#) section for any non-product compliance questions.

Search Parts in this Series

[87381Series](#)

Mates With

[87758](#) Vertical, Through Hole, Stackable PCB Header, [87759](#) Vertical, Surface Mount, Stackable PCB Header, [87760](#) Right Angle, Through Hole, Stackable PCB Header, [87831](#) Vertical, Through Hole PCB Header, [87832](#) Vertical, Surface Mount PCB

Lead-free Process Capability
Max. Cycles at Max. Process Temperature
Process Temperature max. C

Reflow Capable (SMT only)
1
260

Material Info

Reference - Drawing Numbers

Product Specification
Sales Drawing

PS-87380-002
SD-87381-***6*

This document was generated on 04/09/2010

PLEASE CHECK WWW.MOLEX.COM FOR LATEST PART INFORMATION

10 9 8 7 6 5 4 3 2 1

PART NUMBER (SEE NOTE 5)	CKT. SIZE	DIM A	DIM B	DIM C
87381-06**	6	6.00	4.00	0.55
87381-08**	8	8.00	6.00	1.55
87381-10**	10	10.00	8.00	2.55
87381-12**	12	12.00	10.00	3.55
87381-14**	14	14.00	12.00	4.55
87381-16**	16	16.00	14.00	5.55
87381-18**	18	18.00	16.00	6.55
87381-20**	20	20.00	18.00	7.55
87381-22**	22	22.00	20.00	8.55
87381-24**	24	24.00	22.00	9.55
87381-26**	26	26.00	24.00	10.55
87381-28**	28	28.00	26.00	11.55
87381-30**	30	30.00	28.00	12.55
87381-32**	32	32.00	30.00	13.55
87381-34**	34	34.00	32.00	14.55
87381-36**	36	36.00	34.00	15.55
87381-38**	38	38.00	36.00	16.55
87381-40**	40	40.00	38.00	17.55
87381-42**	42	42.00	40.00	18.55
87381-44**	44	44.00	42.00	19.55
87381-46**	46	46.00	44.00	20.55
87381-48**	48	48.00	46.00	21.55
87381-50**	50	50.00	48.00	22.55

PART NO. LEGEND
FOR TUBE PACKAGING ONLY

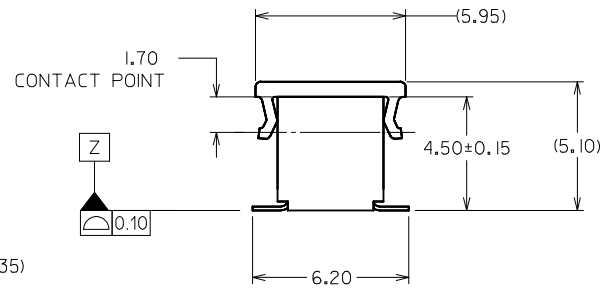
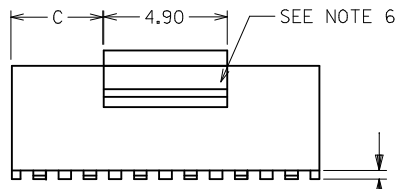
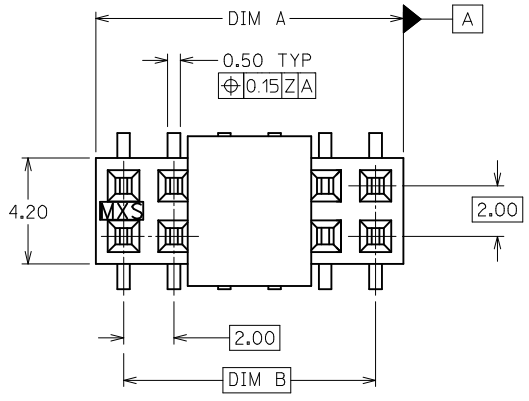
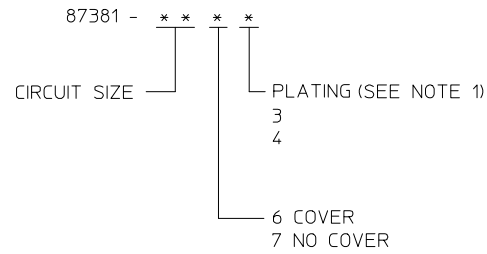

NOTES:

- PLATING FINISH:
 - 3 - 0.76um MIN. GOLD IN CONTACT AREA 1.27um MIN. TIN IN SOLDER TAIL AREA BOTH OVER 1.27um MIN. NICKEL OVERALL
 - 4 - 0.38um MIN. GOLD IN CONTACT AREA 1.27um MIN. TIN IN SOLDER TAIL AREA BOTH OVER 1.27um MIN. NICKEL OVERALL
- 12 CKT SIZE SHOWN FOR ASSY ILLUSTRATION ONLY. (SEE CHART FOR ALL PART SIZES), 6 CKT & 30 CKT ILLUSTRATED FOR TAPE/REEL VERSION ON SHT 2.
- PRODUCT SPECIFICATION PS-87380 APPLIES.
- COPLANARITY OF SOLDER TAILS ARE TO BE MEASURED BY RESTING THE PART ON A FLAT GAUGE SURFACE.
- TUBE PACKAGING STANDARD.
- COVER IS OPTIONAL, SEE LEGEND.
- PARTS SHALL BE PACKED IN MOISTURE BARRIER BAG.
- REFER SHT 3 FOR P/N: 87381-6000 T&R ILLUSTRATION.

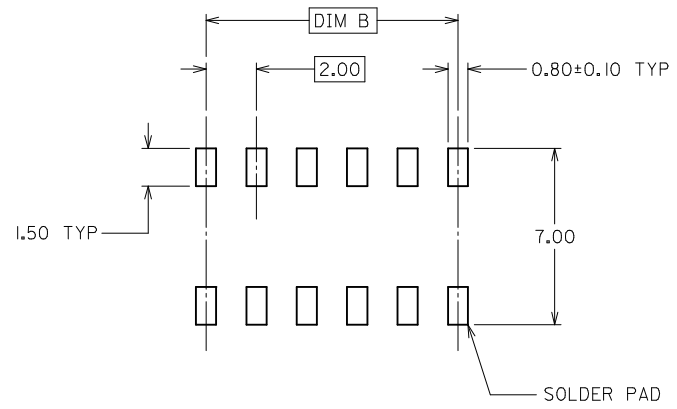

RECOMMENDED PCB LAYOUT

ADD P/N: 87381-3200 EC NO: S2009-0725 DRWN:SKANG CHKD:ATSEE APPR:MLONG 2009/04/01 2009/04/06 2009/04/07	QUALITY SYMBOLS ▽=0 ◻=0	GENERAL TOLERANCES (UNLESS SPECIFIED)		DIMENSION STYLE MM ONLY		SCALE NTS	DESIGN UNITS METRIC	THIRD ANGLE PROJECTION		
			mm	INCH	DRAWN BY	DATE	TITLE			
		4 PLACES	± ---	± ---	JAMES	1998/01/08	MGRID, TOP ENTRY RECEPT. 4.50MM HT., SMT			
		3 PLACES	± ---	± ---	CHECKED BY	DATE	MOLEX INCORPORATED			
	2 PLACES	± 0.20	± ---	LCHANG	1999/04/23	DOCUMENT NO.				
	1 PLACE	± ---	± ---	APPROVED BY	DATE	SHEET NO.				
	ANGULAR ± 3 °		MATERIAL NO.		DOCUMENT NO.		SHEET NO.			
	DRAFT WHERE APPLICABLE MUST REMAIN WITHIN DIMENSIONS		SEE TABLE		SD-87381-***6*		1 OF 4			
			SIZE A3		THIS DRAWING CONTAINS INFORMATION THAT IS PROPRIETARY TO MOLEX INCORPORATED AND SHOULD NOT BE USED WITHOUT WRITTEN PERMISSION					

9 8 7 6 5 4 3 2 1

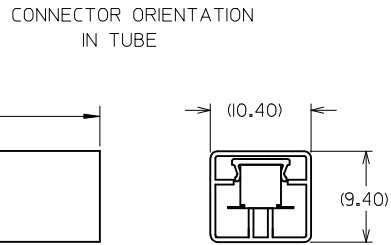
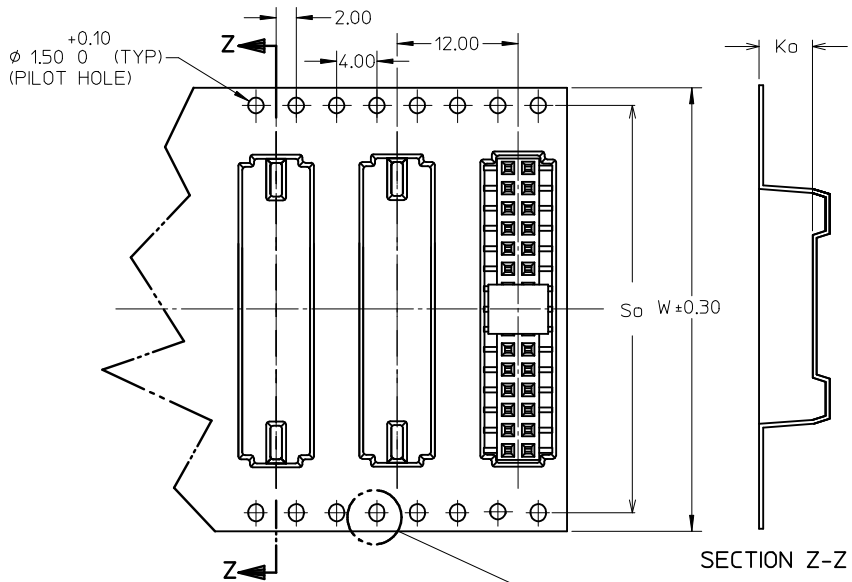

30 CKT FOR ILLUSTRATION ONLY
TAPE & REEL TYPE 'B'

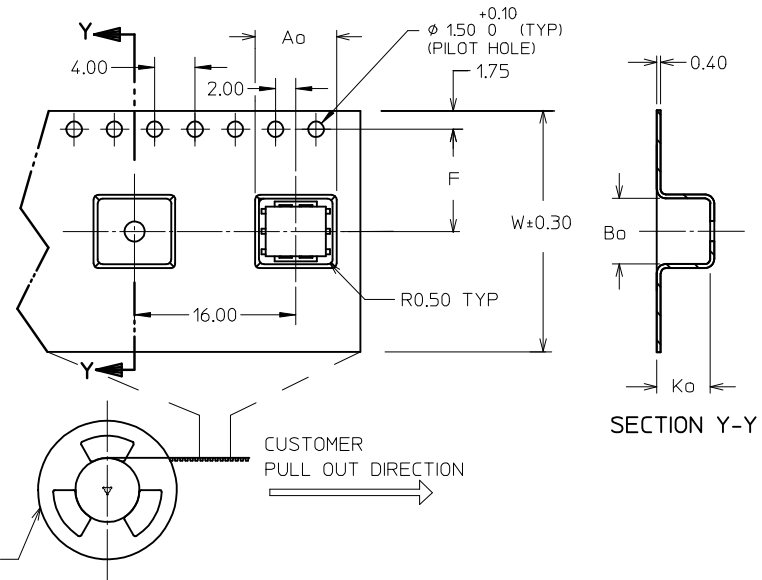
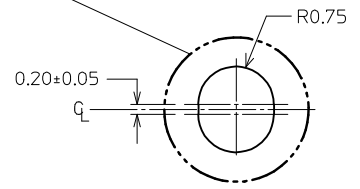

6 CKT FOR ILLUSTRATION ONLY
TAPE & REEL TYPE 'A'

NOTES:

- LEADER AND TRAILER TAPE
- PEELING OFF FORCE OF THE TOP TAPE: 20-80gf.
(PEELING DIRECTION AS SHOWN IN FOLLOWING FIGURE)
- PACKAGING STANDARD IS AS PER EIA-481.
- TAPE & REEL QUANTITY = SEE TABLE

ADD P/N: 87381-3200	2009/04/07
EC NO: S2009-0725	2009/04/07
DRWN:SKANG	2009/04/06
CHKD:ATSEE	2009/04/06
APPR:MLONG	2009/04/07

REV	DESCRIPTION
8	

QUALITY SYMBOLS	
	= 0
	= 0

GENERAL TOLERANCES (UNLESS SPECIFIED)	
	mm
4 PLACES	± ---
3 PLACES	± ---
2 PLACES	± 0.20
1 PLACE	± ---
ANGULAR ± 3 °	

DIMENSION STYLE	
MM ONLY	
DRAWN BY	DATE
JAMES	1998/01/08
CHECKED BY	DATE
LCHANG	1999/04/23
APPROVED BY	DATE
SQUEK	1999/04/26
MATERIAL NO.	
SEE TABLE	

SCALE	DESIGN UNITS	THIRD ANGLE PROJECTION
NTS	METRIC	
TITLE		
MGRID, TOP ENTRY RECEPT. 4.50MM HT., SMT		
MOLEX INCORPORATED		
DOCUMENT NO.	SHEET NO.	
SD-87381-***6*	2 OF 4	

10 9 8 7 6 5 4 3 2 1

CKT SIZE	PART NO. WITH CAP IN TUBE	PART NO. WITH CAP IN TAPE / REEL	W	So	Ao	F	Bo	Ko	T&R TYPE (SHT 2)	T&R QTY PER REEL
6	87381-0664	87381-9002	24	-	7.00	11.50	6.50	5.30	A	500
8	87381-0864	87381-9003	24	-	7.00	11.50	8.50	5.30	A	600
10	87381-1064	87381-9005	24	-	7.00	11.50	10.50	5.30	A	680
14	87381-1464	87381-9006	32	28.40	7.20	14.20	14.50	5.30	B	750
16	87381-1664	87381-9004	32	28.40	7.20	14.20	16.50	5.30	B	800
18	87381-1864	87381-1800	32	28.40	7.20	14.20	18.50	5.30	B	750
20	87381-2063	87381-2000	32	28.40	7.20	14.20	20.50	5.30	B	800
22	87381-2264	87381-2200	44	40.40	7.20	20.20	22.50	5.30	B	500
30	87381-3064	87381-3000	44	40.40	7.20	20.20	30.50	5.30	B	500
32	87381-3264	87381-3200	44	40.40	7.20	20.20	32.50	5.30	B	500
44	87381-4464	87381-4400	56	52.40	7.20	26.20	44.50	5.30	B	500
46	87381-4664	87381-4600	72	68.40	7.20	34.20	46.50	5.30	B	750
50	87381-5063	87381-5030	72	68.40	7.20	34.20	50.50	5.30	B	500
50	87381-5064	87381-5000	72	68.40	7.20	34.20	50.50	5.30	B	500

ADD P/N: 87381-3200 EC NO: S2009-0725 DRWN:SKANG CHKD:ATSEE APPR:MLONG	2009/04/07 2009/04/06 2009/04/07	DESCRIPTION REV	QUALITY SYMBOLS	GENERAL TOLERANCES (UNLESS SPECIFIED)	DIMENSION STYLE	SCALE	DESIGN UNITS	THIRD ANGLE PROJECTION		
			$\nabla = 0$ $\square = 0$	mm INCH 4 PLACES ± --- ± --- 3 PLACES ± --- ± --- 2 PLACES ± 0.20 ± --- 1 PLACE ± --- ± --- ANGULAR ± 3 °	MM ONLY	NTS	METRIC	DRAWN BY DATE JAMES 1998/01/08 CHECKED BY DATE LCHANG 1999/04/23 APPROVED BY DATE SQUEK 1999/04/26	TITLE	MGRID, TOP ENTRY RECEPT. 4.50MM HT., SMT
				DRAFT WHERE APPLICABLE MUST REMAIN WITHIN DIMENSIONS	SEE TABLE	MOLEX INCORPORATED SD-87381-***6*	SHEET NO. 3 OF 4			
					THIS DRAWING CONTAINS INFORMATION THAT IS PROPRIETARY TO MOLEX INCORPORATED AND SHOULD NOT BE USED WITHOUT WRITTEN PERMISSION					

9 8 7 6 5 4 3 2 1

CKT SIZE	PART NO. WITHOUT CAP IN TUBE	PART NO. WITHOUT CAP IN TAPE / REEL	W	So	Ao	F	Bo	Ko	T&R TYPE (SHT 2)	T&R QTY PER REEL
50	87381-5074	87381-6000 $\triangle/8$	72	68.40	6.80	34.20	50.50	8.00	B	500

$\triangle/8$ ILLUSTRATION FOR P/N: 87381-6000
50 CKT IN T&R W/O CAP

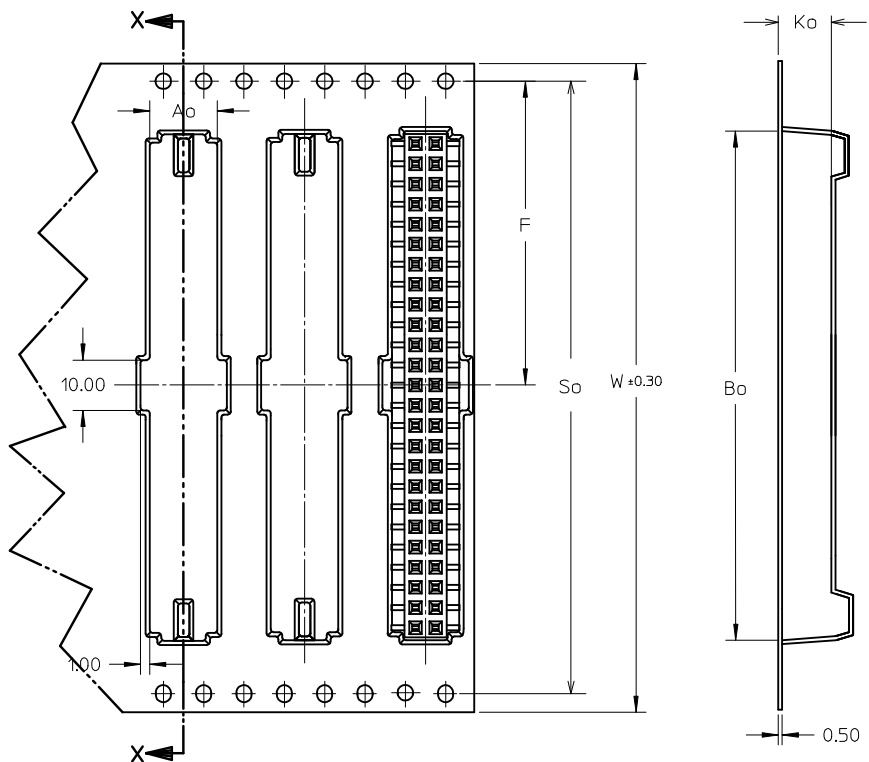

SECTION X-X

ADD P/N: 87381-3200 EC NO: S2009-0725 DRWN:SKANG 2009/04/07 CHKD:ATSEE 2009/04/06 APPR:MLONG 2009/04/07	QUALITY SYMBOLS $\blacktriangledown=0$ $\triangle=0$	GENERAL TOLERANCES (UNLESS SPECIFIED)		DIMENSION STYLE MM ONLY		SCALE NTS	DESIGN UNITS METRIC	THIRD ANGLE PROJECTION		
			mm	INCH	DRAWN BY JAMES	DATE 1998/01/08	TITLE MGRID, TOP ENTRY RECEPT. 4.50MM HT., SMT			
		4 PLACES	\pm ---	\pm ---	CHECKED BY LCHANG	DATE 1999/04/23	MOLEX INCORPORATED DOCUMENT NO. SD-87381-***6* SHEET NO. 4 OF 4			
		3 PLACES	\pm ---	\pm ---	APPROVED BY SQUEK	DATE 1999/04/26				
2 PLACES	\pm 0.20	\pm ---	ANGULAR \pm 3 °		MATERIAL NO.		SEE TABLE			
1 PLACE	\pm ---	\pm ---	DRAFT WHERE APPLICABLE MUST REMAIN WITHIN DIMENSIONS		SIZE A3		THIS DRAWING CONTAINS INFORMATION THAT IS PROPRIETARY TO MOLEX INCORPORATED AND SHOULD NOT BE USED WITHOUT WRITTEN PERMISSION			